

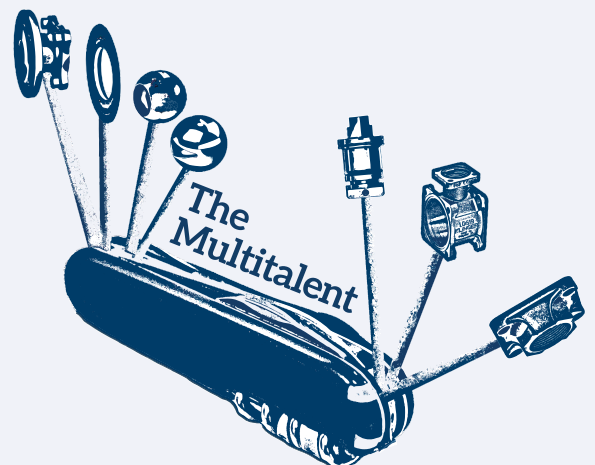

KLINGER BALLOSTAR® KHA

3-piece ball valves
DN 15-125



KLINGER FLUID CONTROL

Today for tomorrow

As a subsidiary of the KLINGER Group, KLINGER Fluid Control has been developing, manufacturing and maintaining high-quality industrial valves at the business location Gumpoldskirchen, Austria, for more than 135 years. Via the global distribution and service network, KLINGER Fluid Control offers both standardized and tailored products, services as well as solutions for customers around the globe.

Products from KLINGER Fluid Control are characterized by their high level of reliability as well as by an above average lifecycle at a simultaneously very low total cost of ownership (TCO). As a solutions partner, KLINGER Fluid Control creates customer benefits with added value. In this regard, the focus is on the following core competences:



ENCOMPASSING SERVICE

- » Application expertise
- » Product trainings
- » Fast quotation and order processing
- » Customer-specific logistics concepts
- » Supply of spare parts
- » Valve maintenance
- » On-site technical support

INNOVATIVE SOLUTIONS

- » State of the art development tools
- » Product development for different areas of application
- » Compilation of customer-specific special solutions
- » Automation solutions
- » Product tests in the company-own technical center
- » A wide range of certificates and approvals



OPERATIONAL EXCELLENCE

- » Flexible production
- » Transparency in the supply chain
- » Short delivery times
- » ISO 9001 certified quality
- » ISO 14001 as well as EMAS certified environmental management system

TECHNICAL HIGHLIGHTS

Absolute operational safety with certified quality

FIRE SAFETY

The ball valve can be used for fire safe applications at any given time as the basic design is already certified per default. In this context, the KLINGER Ballostar KHA offers a more stable bolting of the body with shorter bolts for greater mechanical stability with regard to thermal expansion. The type-testing fire safety requirements in accordance with API Standard 607, 7th Edition, and EN ISO 10497:2010 have been officially certified.

IMPROVED CORROSION PROTECTION

KLINGER Advanced Corrosion Protection is a newly developed, special coating procedure with galvanic coating ensuring improved protection against corrosion. An impressive value of 400 h was determined in the course of a "neutral salt spray mist test" in accordance with ISO 9227. A comparison: Common phosphatization leads to 20 h, while standard finishing only results in 100 h of protection. This value corresponds to a salt spray test duration comparable with a C3 coating in accordance with ISO 12944-1.

SERIAL ANTISTATIC

The KLINGER Ballostar KHA features serial antistatic equipment in accordance with ISO 7121 and EN 1983 respectively. In this context, an antistatic ball, from DN 50 upwards, ensures the electrostatic discharge.

TA-LUFT (VDI 2440)

The standard stuffing box meets the requirements of TA Luft (VDI 2440). Double sealing at the body division by means of the KLINGERSIL® C-4430 soft gasket protects against external leakages and meets the highest helium emission testing requirements. The KLINGER Ballostar KHA is significantly below the requirements of emission limits to keep air clean.

OXYGEN DESIGN

Due to the fact that increased concentrations of oxygen lead to greater fire and explosion hazards, a valve must also meet certain pre-requirements in terms of oxygen. The Federal Institute for Materials Research and Testing in Berlin has tested the KLINGER Ballostar KHA for utilization with oxygen.

STANDARDS-COMPLIANT MARKING

Standards-compliant marking in accordance with EN 19 is executed on the KLINGER Ballostar KHA by means of laser. The parameters DN, PN, year of manufacture, serial number, material, type and maximum temperature resistance are listed.



THE MULTITALENT

One product – many applications



PRODUCT ADVANTAGES

- » Maintenance-free
- » Supports pressurization on both sides
- » Bidirectional flow
- » Ball with a cylindrical full bore
- » Standard version Fire Safe certified
- » Standard version TA Luft (VDI 2440) certified
- » Greater mechanical robustness while exposed to thermal stress
- » Unique pre-stressed and elastic sealing system
- » Bidirectional sealing in accordance with EN 12266 – leakage rate A
- » Modular selection of system components
- » Serviceable without removal from the line
- » Antistatic design in accordance with ISO 7121 / EN 1983
- » Subsequent automation possible at any time (top flange in accordance with EN ISO 5211)



SPECIAL TYPES

- » Metal seat (up to +400 °C) for abrasive media
- » Operating stem sealed by O-rings
- » Operating stem extension
- » Oxygen version (oil, grease and silicone-free)
- » Cryogenic version (down to -196 °C)
- » Vacuum version
- » Gas version
- » Regulation design by means of V-port ball and actuator package
- » Double-seated execution
- » Double Block & Bleed execution with drain valve



PRODUCT DETAILS

PN	16/25/40/63/100
DN	15-125
Housing	Cast steel, rust and acid-proof cast iron, duplex
Ball	1.4044 / special materials on demand
Operating stem	Rust and acid-proof steel
Temperature	-196 °C to +400 °C
Design	Flanges, threaded connection, welding ends
Type	Three-piece ball valve

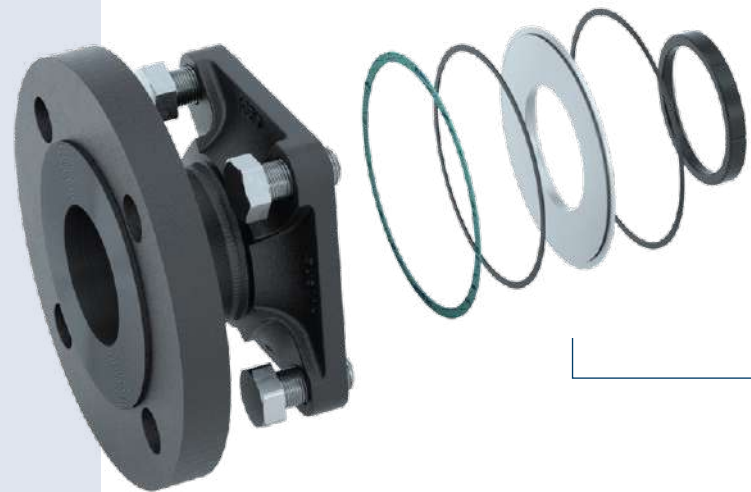
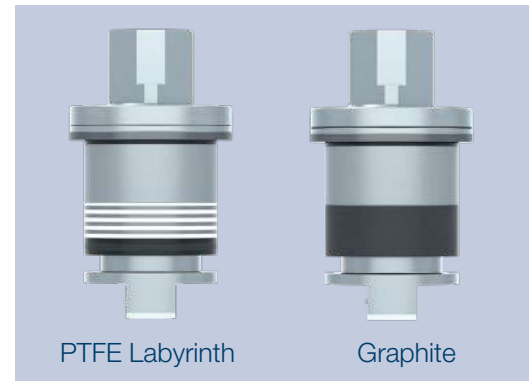

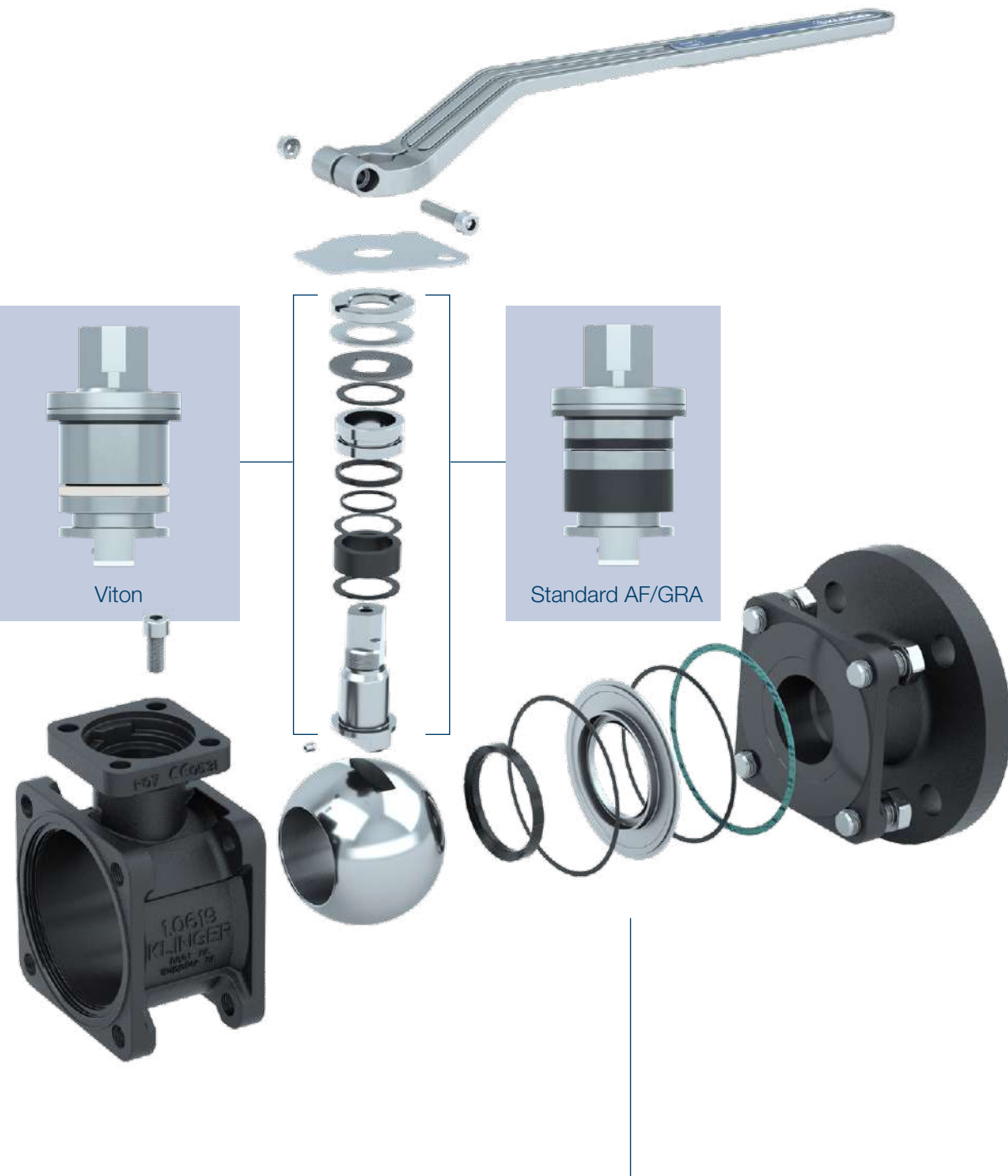

WHAT YOU CAN RELY ON

The unique KLINGER sealing system

The sealing element is the heart of every valve. The type of sealing defines under which conditions a valve can reliably execute its shut-off or regulating function. Leakages and the negative consequences resulting thereof are an immense

challenge for plant operators. A seal that keeps its promises is therefore a must.

With the new Ballostar KHA KLINGER has created a ball valve that absolutely convinces with its unique sealing system!

THE OPTIMIZED SEALING SYSTEM

A KLINGERSIL® C-4430

The fire safety requirements have been integrated into the standard design of the Ballostar KHA. The soft material gasket KLINGERSIL® C-4430 protects against external leakages and meets the highest helium emission testing requirements.

B GRAPHITE GASKET

The graphite layer also protects against leakage to the atmosphere during high-temperature applications and, in combination with the KLINGERSIL® gasket, forms a double seal at the housing partition. This provides the highest degree of safety against external leakages.

C ELASTIC, SINGLE-PART SEALING ELEMENT

The sealing element provides functionality across the entire lifecycle and simultaneously ensures the required contact pressure of the sealing ring. The valve therefore remains continuously tight – independent of the pressure of the medium and the flow direction.

D SEALING RING

The sealing ring forms the basis of every functioning sealing system. It stands for the highest quality and reliability in accordance with the KLINGER standard! The fiber-reinforced sealing ring KLINGER KFC-25 consists of PTFE and graphite

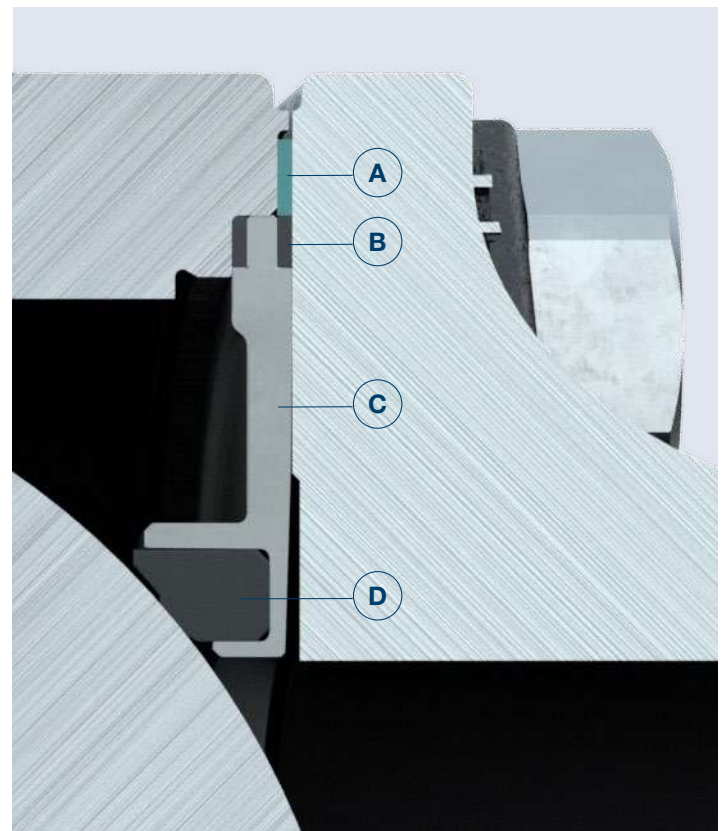

and is surrounded on three sides by the spring-loaded sealing element. It can thus absorb large amounts of contact force without deformation and is simultaneously protected against the medium.

As a globally leading manufacturer, KLINGER offers valves and sealing elements from one source. We pass on this synergetic benefit with more than 135 years of experience and a high degree of competence to our customers.

WHAT YOU CAN RELY ON

Stuffing box selection

The KLINGER Ballostar KHA ball valve is fitted with the Standard AF/GRA stuffing box per default. Other designs can be selected in accordance with the desired application and optionally requested.

THE STANDARD STUFFING BOX

- » Standard design
- » Resealable
- » Additionally secured with Loctite
- » Temperatures up to 300 °C
- » Material graphite and Aflas
- » Fire-Safe certified
- » VDI 2440 certified (TA Luft)



Standard AF/GRA

THE GRAPHITE STUFFING BOX

- » Resealable
- » Additionally secured with Loctite
- » High-temperature applications
- » Temperatures up to 400 °C
- » Resistant against frequent temperature fluctuations



Graphite

O-RING VITON STUFFING BOX

- » For gas applications
- » Maintenance-free
- » Additionally secured with Loctite
- » ÖVGW certificate
- » Excellent gliding properties



Viton

THE LABYRINTH STUFFING BOX

- » Resealable
- » Maintenance-free
- » Additionally secured with Loctite
- » Excellent gliding properties
- » Material PTFE and stainless steel



PTFE Labyrinth

DOUBLE BLOCK & BLEED

The safest solution for maintenance

BALLOSTAR KHA-DBB

A single ball valve instead of two? With the Double Block & Bleed (DBB) function, we offer a perfect solution regarding lifecycle costs.

As opposed to the floating design, the 3-piece ball valve is in this case trunnion mounted. This construction alternative (for nominal widths between 50 and 125 mm) improves durability, enabling the ball valve to guarantee optimal functionality and operational safety even under the most demanding conditions.

Next to time and cost savings, the optional Double Block & Bleed function, either with a drain valve or drainage by way of the trunnion, is important in applications featuring limited installation space.

Furthermore, the BALLOSTAR KHA-DBB convinces with its sealing and safety features.

There are two different versions available:

1. Trunnion mounted
2. Trunnion mounted with drain cock (complete Double Block & Bleed solution)



INSULATION IN DETAIL

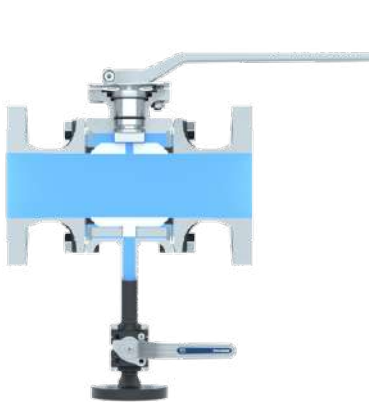

KHA ball valve fully open



KHA ball valve completely closed, dead space and ball filled with medium

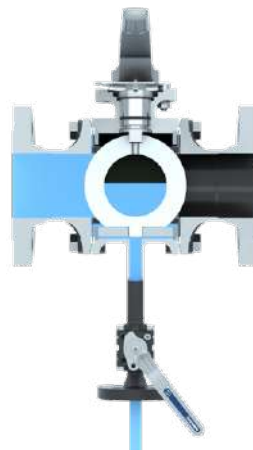

Opening of the drain cock. Complete drainage of the dead space and inner space

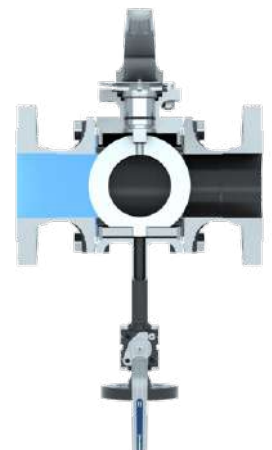

KHA ball valve completely closed with opened drain cock. Dead space and ball completely emptied.

DISASSEMBLY? NO THANKS!

Simple maintenance without
removal from the pipe system

The nuts (2)-(4) must be removed for maintenance and servicing, the remaining nut, however, is only loosened (1). This allows the core of the valve to be swung out of the pipe system with little effort and without disassembly, rendering access to the two sealing elements as well as the soft material gasket

KLINGERSIL® C-4430. They can also be easily removed and replaced. An exchanging of the stuffing box seals, the removal of the ball and the operating stem also feature a highly user-friendly execution.

NOW RETRACTABLE IN EVERY VERSION

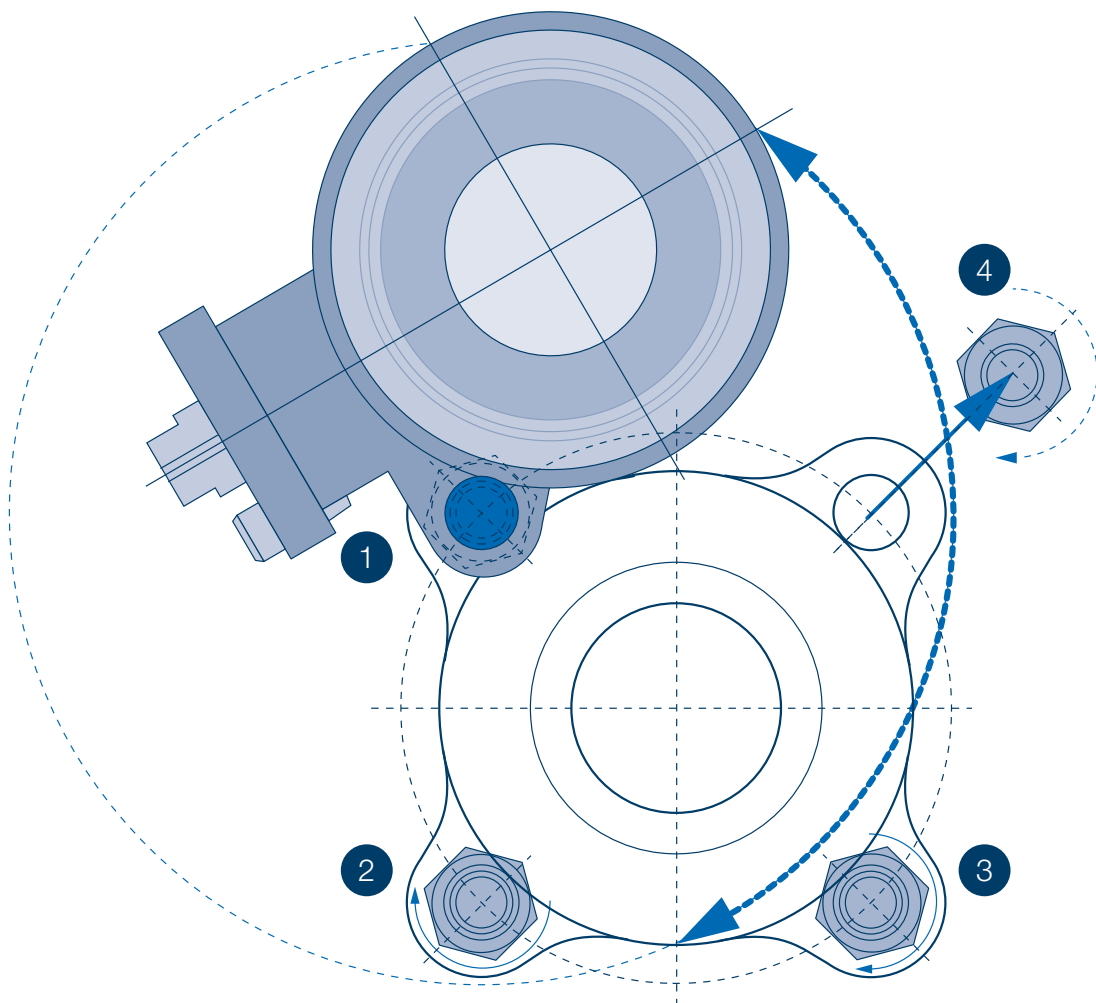

SUSTAINABLE EFFICIENCY

Cost efficiency and reliability at its best

The KLINGER Ballostar KHA is characterized by its low costs across the entire lifecycle of the valve (total cost of ownership – TCO) as well as by its extreme longevity. Due to its modular build, only affected components need to be replaced in the course of maintenance. This significantly increases the service life of the valve in the system. The plant operator therefore profits from lower costs during plant

maintenance as well as from reduced storage and installation costs – while continuously retaining high levels of safety. With its unique design the KLINGER Ballostar KHA also offers plant operators the flexibility demanded by today's dynamic markets: Thanks to a broad selection of individually combinable modular system components, the ball valve can be equipped, refitted or even retrofitted for every possible application.

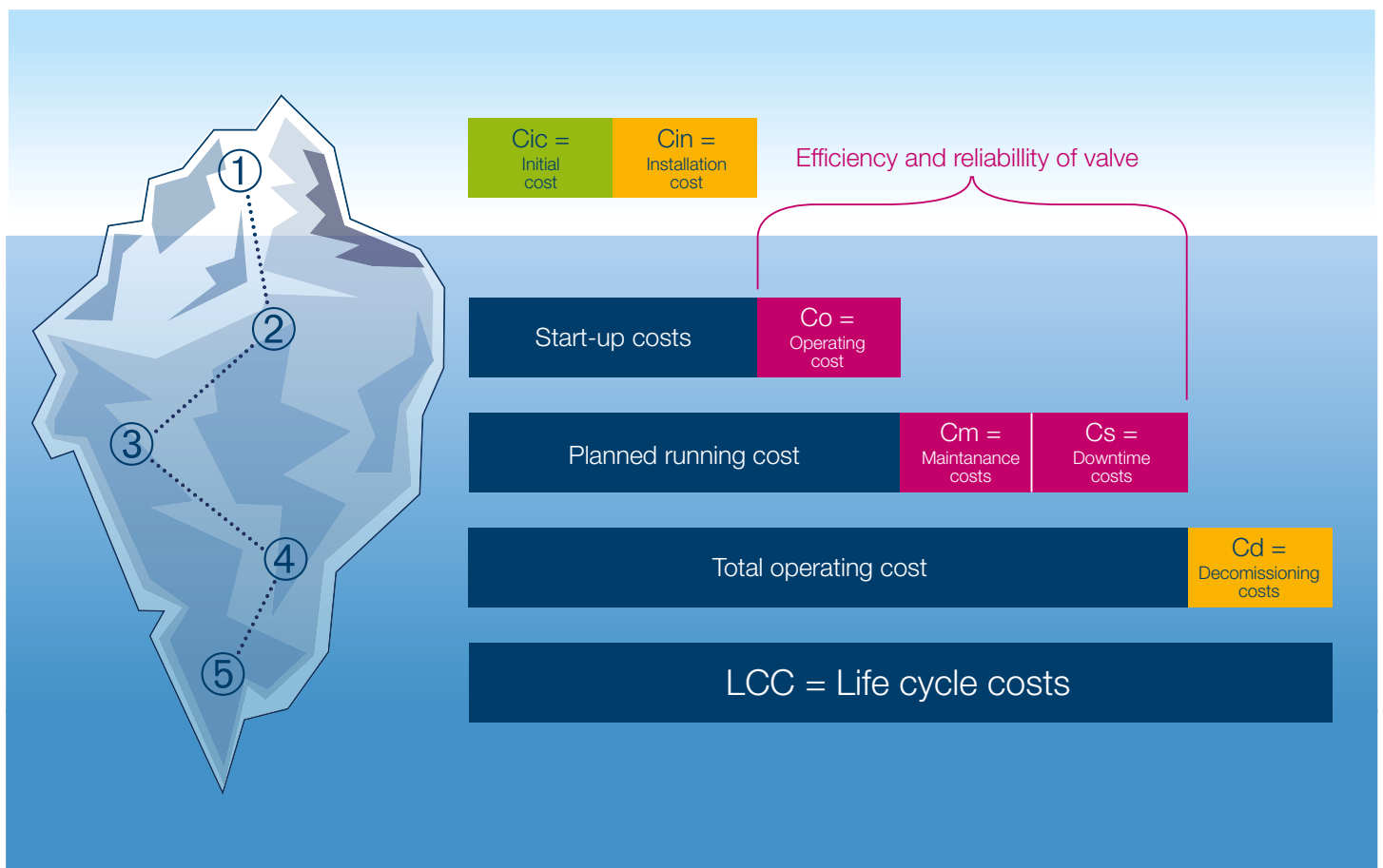

① **Cic** = Initial cost + **Cin** = Installation costs

② Start-up costs + **Co** (Operating costs (C_o)) are costs associated with keeping the plant running (more specifically energy costs associated with pressure loss).

③ Planned running costs + **Cm** + **Cs**
Cm = Maintenance costs for KLINGER Fluid Control ball valves are very low due to the avoidance of the following:
 Operating and checking the valve on a regular basis.
 Dismantling the valve to change the sealing element.
 Installation of the repaired or a new valve in the line.

Cs = Downtime costs can be very high. Emptying the pipe, repairing the valve as well as refilling and testing the network section can generate 20 to 30 % additional costs on top of the cost for the downtime.

④ Total operating Costs + **Cd** (Decommissioning cost, which is the cost incurred by companies in reversing the modifications made to landscape when a fixed asset is used up).

BALLOSTAR KHA

Product overview

» KHA-F
Flange design

» 12



» KHA-S
Welding ends

» 13



» KHA-G
Threaded connection

» 14



» KHA-DBB
Double Block & Bleed » 15-17



» KHA
With actuator

» 18-19



» KHA
Stem extension

» 20



BALLOSTAR KHA-F

Flange design

GENERAL FEATURES

- » 3-piece ball valve with full bore
- » Floating ball, antistatic, lockable
- » Double tightness in both directions
- » Modular system components

CONNECTIONS

- » Flange in accordance with DIN EN 1092-1 or ASME B 16.5

DIMENSIONS

Face-to-face dimensions in accordance with EN 558-1, series 1 or dimensions in accordance with ANSI B16.10 CL 300

ACCEPTANCE TESTING

- » Seat leak tightness: EN 12266-1 P12, leakage rate A
- » Tightness to atmosphere: EN 12266-1 P11
- » Strength: EN 12266-1 P10

AUTOMATION

- » Flange connection in accordance with ISO 5211, allows for direct mounting of an actuator or by means of brackets. Pneumatic and electrical actuators utilizable.

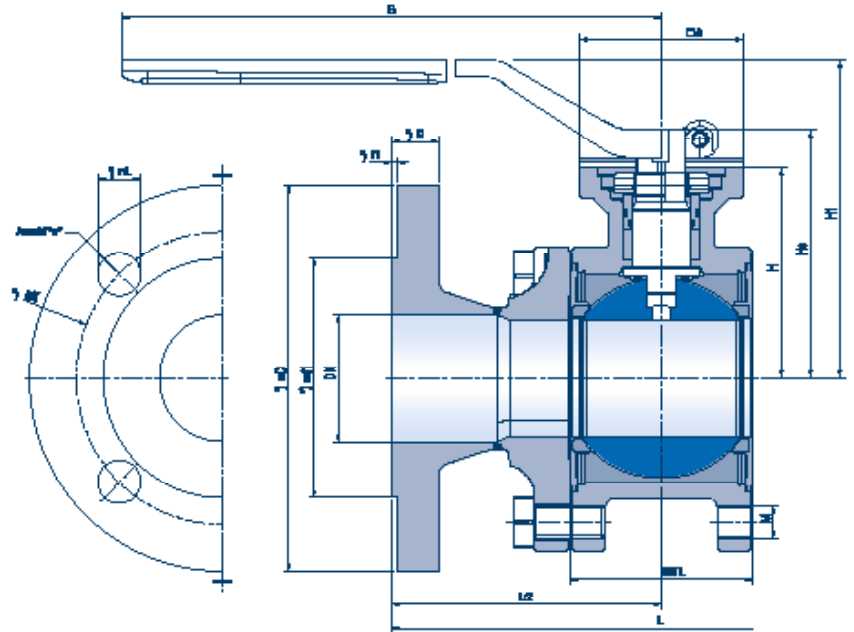

TEMPERATURE

-196 °C to +400 °C (see pT diagram)

* Flange dimensions in accordance with DIN EN 1092-1 or ASME B 16.5

DN	Dimensions											Pressure level		Head flange size acc. to ISO 5211	Weight [kg]
	MTL	ØA	H	Hs	H1	G	SW	M	L (EN)	L (ASME)	VIII	Xc			
15	1/2"	26.4	42	35.0	43.5	83.0	130	8	M6	130	140	100	63	F04	2.3
20	3/4"	35.2	42	46.5	57.0	96.0	160	11	M8	150	152	100	63	F04	3.5
25	1"	41.5	42	50.0	60.5	100.0	160	11	M8	160	165	100	63	F04	4.3
32	1-1/4"	49.5	50	65.0	77.7	107.5	252	14	M10	180	178	63	40	F05	6.8
40	1-1/2"	63.0	50	72.5	85.2	114.7	252	14	M12	200	190	63	40	F05	9.0
50	2"	77.5	70	90.0	106.2	136.2	310	17	M14	230	216	40	40	F07	13.5
65	2-1/2"	93.5	70	100.0	116.2	146.2	310	17	M12	290	241	40	40	F07	18.0
80	3"	111.4	102	121.5	143.0	165.0	500	22	M16	310	282	40	40	F10	28.8
100	4"	131.6	102	135.0	156.5	178.5	500	22	M16	350	305	40	40	F10	40.6
125	5"	171.4	125	175.0	202.5	212.5	650	27	M16	400	381	40	40	F12	66.0

BALLOSTAR KHA-S

Welding ends

GENERAL FEATURES

- » 3-piece ball valve with full bore
- » Floating ball, antistatic, lockable
- » Double tightness in both directions
- » Modular system components

CONNECTIONS

Welding ends in accordance with DIN EN 12627

DIMENSIONS

Dimensions in accordance with DIN EN 12982, series 67 (DN 15-125)

ACCEPTANCE TESTING

- » Seat leak tightness: EN 12266-1 P12, leakage rate A
- » Tightness to atmosphere: EN 12266-1 P11
- » Strength: EN 12266-1 P10

AUTOMATION

Flange connection in accordance with ISO 5211, allows for direct mounting of an actuator or by means of brackets. Pneumatic and electrical actuators utilizable.

TEMPERATURE

-196 °C to +400 °C (see pT diagram)

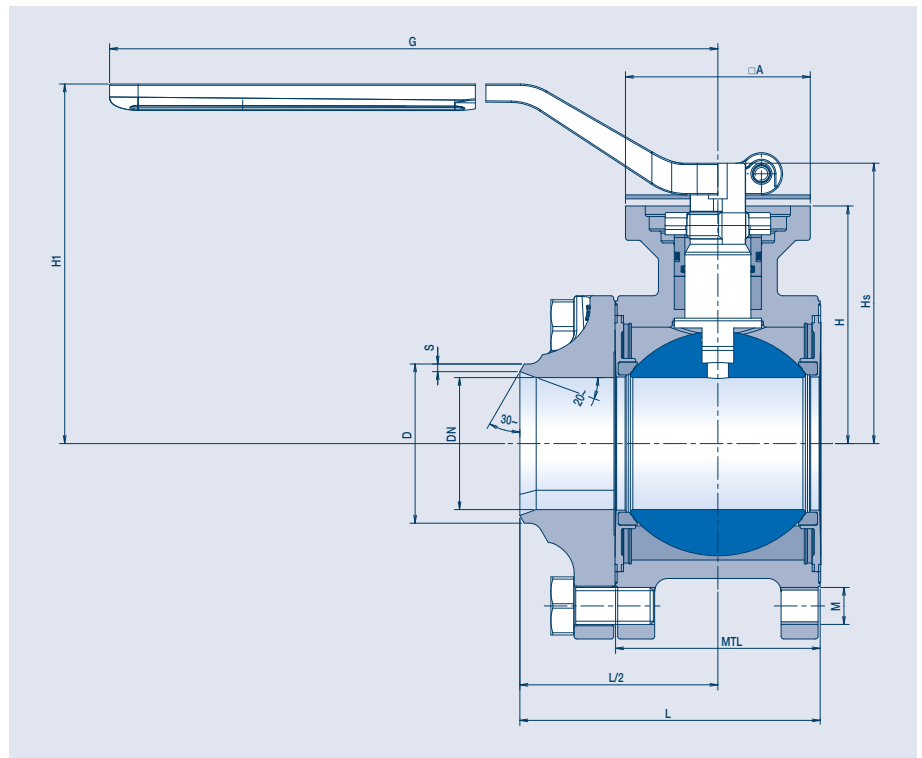

NOTICE: DOES NOT HAVE TO BE DISMANTLED WHEN WELDING INTO THE PIPELINE

DN	Dimensions											Pressure level		Head flange size acc. to ISO 5211	Weight [kg]
	MTL	D	S	ØA	H	Hs	H1	G	SW	M	Total face-to-face length L	VIII	Xc		
15	26.4	21.3	2.0	42	35.0	43.5	83.0	130	8	M6	75	100	63	F04	0.85
20	35.2	28.0	3.0	42	46.5	57.0	96.0	160	11	M8	90	100	63	F04	1.45
25	41.5	33.7	2.6	42	50.0	60.5	100.0	160	11	M8	105	100	63	F04	1.80
32	49.5	42.4	2.6	50	65.0	77.7	107.5	252	14	M10	110	63	40	F05	3.10
40	63.0	48.3	3.2	50	72.5	85.2	114.7	252	14	M12	125	63	40	F05	4.75
50	77.5	60.3	2.9	70	90.0	106.2	136.2	310	17	M14	150	40	40	F07	7.60
65	93.5	76.1	3.1	70	100.0	116.2	146.2	310	17	M12	190	40	40	F07	10.60
80	111.4	88.9	3.2	102	121.5	143.0	165.0	500	22	M16	220	40	40	F10	19.50
100	131.6	114.3	3.6	102	135.0	156.5	178.5	500	22	M16	270	40	40	F10	28.00
125	171.4	139.7	4.0	125	175.0	202.5	212.5	650	27	M16	330	40	40	F12	49.50

BALLOSTAR KHA-G

Threaded connection

GENERAL FEATURES

- » 3-piece ball valve with full bore
- » Floating ball, antistatic, lockable
- » Double tightness in both directions
- » Modular system components

CONNECTIONS

- » Internal thread Rp in accordance with EN 10226-1
- » Internal thread in accordance with NPT ANSI B 1.20.1

DIMENSIONS

Face-to-face dimensions in accordance with EN 16722-114

ACCEPTANCE TESTING

- » Seat leak tightness: EN 12266-1 P12, leakage rate A
- » Tightness to atmosphere: EN 12266-1 P11
- » Strength: DIN EN 12266-1 P10

AUTOMATION

- » Flange connection in accordance with ISO 5211, allows for direct mounting of an actuator or by means of brackets.
- » Pneumatic and electrical actuators utilizable.

TEMPERATURE

-196 °C to +400 °C (see pT diagram)

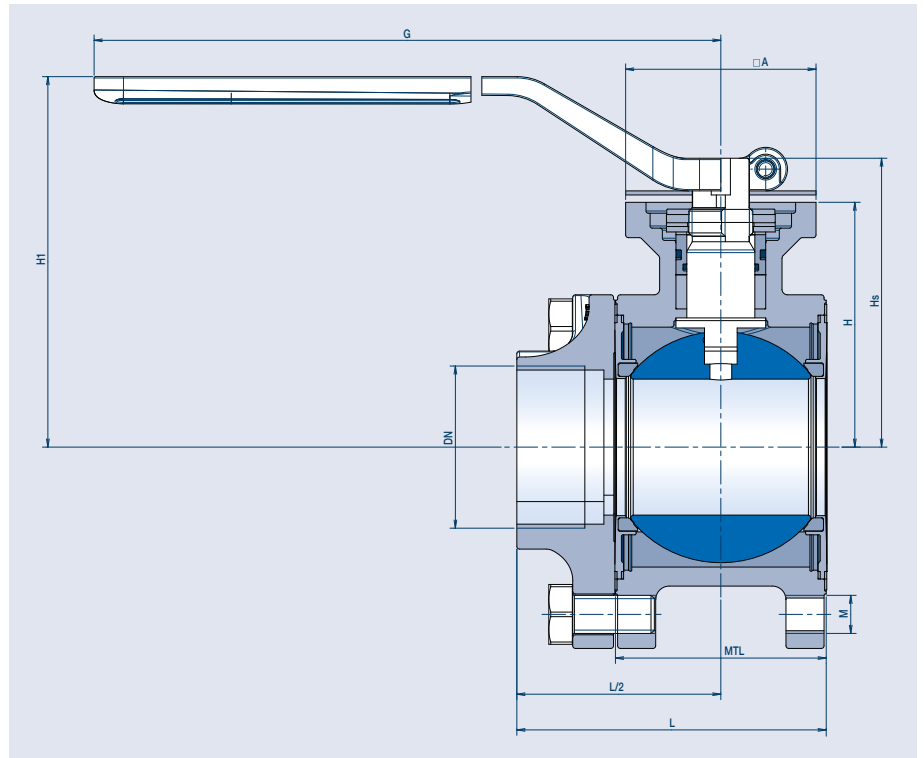

DN	Dimensions										Pressure level		Head flange size acc. to ISO 5211	Weight [kg]
	MTL	ØA	H	Hs	H1	G	SW	M	L	Xc	VIII	Xc		
1/2"	26.4	42	35.0	43.5	83.0	130	8	M6	85	63	100	63	F04	0.90
3/4"	35.2	42	46.5	57.0	96.0	160	11	M8	95	63	100	63	F04	1.45
1"	41.5	42	50.0	60.5	100.0	160	11	M8	105	63	100	63	F04	1.80
1-1/4"	49.5	50	65.0	77.7	107.5	252	14	M10	120	40	63	40	F05	3.15
1-1/2"	63.0	50	72.5	85.2	114.7	252	14	M12	130	40	63	40	F05	4.75
2"	77.5	70	90.0	106.2	136.2	310	17	M14	150	40	40	40	F07	7.55

BALLOSTAR KHA-DBB

Double Block & Bleed DN 15-40

GENERAL FEATURES

- » 3-piece ball valve with full bore
- » Double-seated ball, antistatic, lockable
- » Optionally only as a double-seated ball valve or with a drain valve
- » Double sealing in both bore directions
- » Modular component system

CONNECTIONS

- » Flange
- » Welding ends
- » Threads

DIMENSIONS

See previous technical data sheets for face-to-face dimensions

ACCEPTANCE TESTING

- » Seat tightness: EN 12266-1 P12, Leakage rate A
- » Tightness to atmosphere: EN 12266-1 P11
- » Body strength: EN 12266-1 P10

AUTOMATION

The flanged connection in accordance with ISO 5211 allows for direct mounting of an actuator or by means of a console. Pneumatic and electrical actuators possible.

TEMPERATURE

-10 °C to +200 °C (see pT-Diagramm)

DN	H
15	110.0
20	116.7
25	119.0
32	126.5
40	135.5

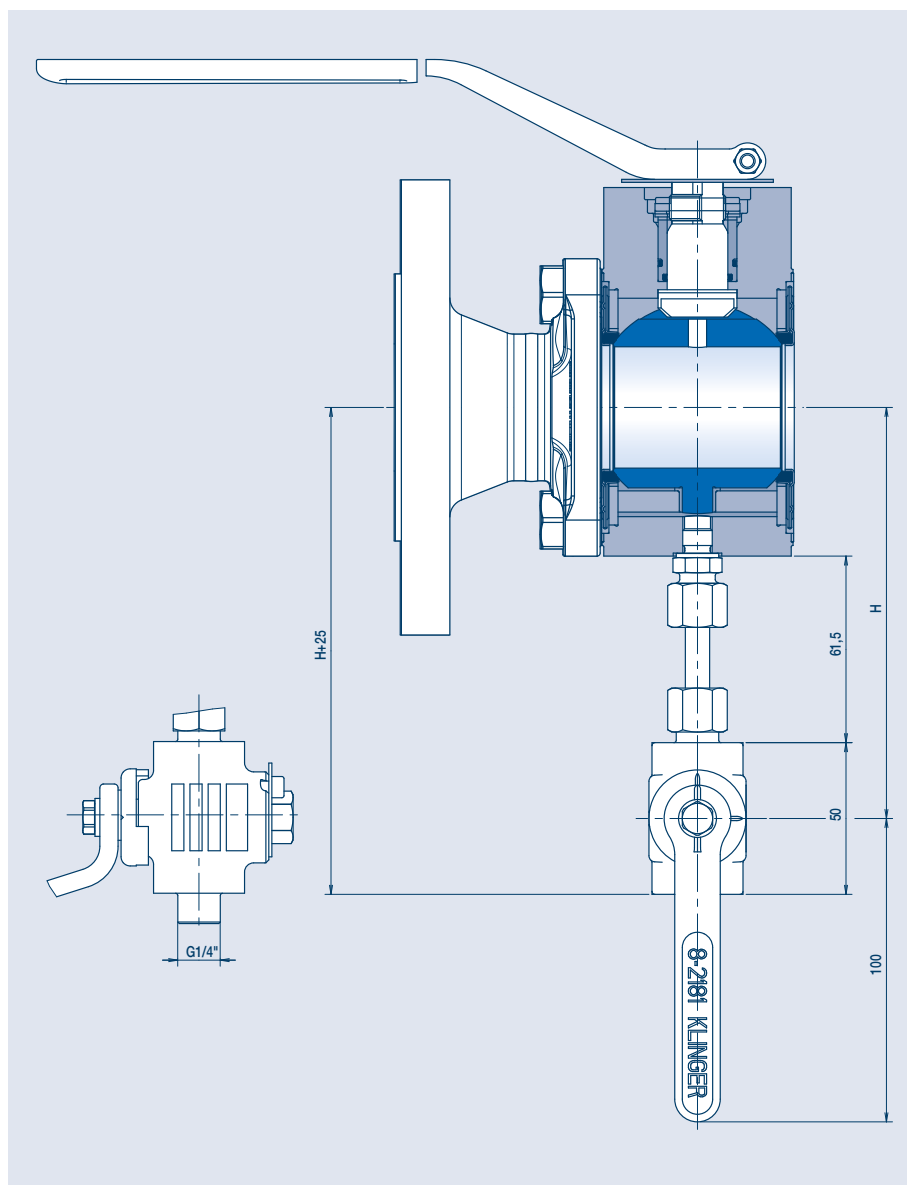

BALLOSTAR KHA-DBB

Double Block & Bleed DN 50-125

GENERAL FEATURES

- » 3-piece ball valve with full bore
- » Double-seated ball, antistatic, lockable
- » Optionally only as a double-seated ball valve or with a drain valve
- » Double sealing in both bore directions
- » Modular component system

CONNECTIONS

- » Flange
- » Welding ends
- » Threads

DIMENSIONS

See previous technical datasheets for face-to-face dimensions

ACCEPTANCE TESTING

- » Seat tightness: EN 12266-1 P12, Leakage rate A
- » Tightness to atmosphere: EN 12266-1 P11
- » Body strength: EN 12266-1 P10

AUTOMATION

The flanged connection in accordance with ISO 5211 allows for direct mounting of an actuator or by means of a console. Pneumatic and electrical actuators possible.

TEMPERATURE

-10 °C to +200 °C (see pT-Diagramm)

DN	H	H1
50	182.5	99.6
65	192.4	95.0
80	204.4	92.5
100	217.4	89.5
125	240.4	81.5

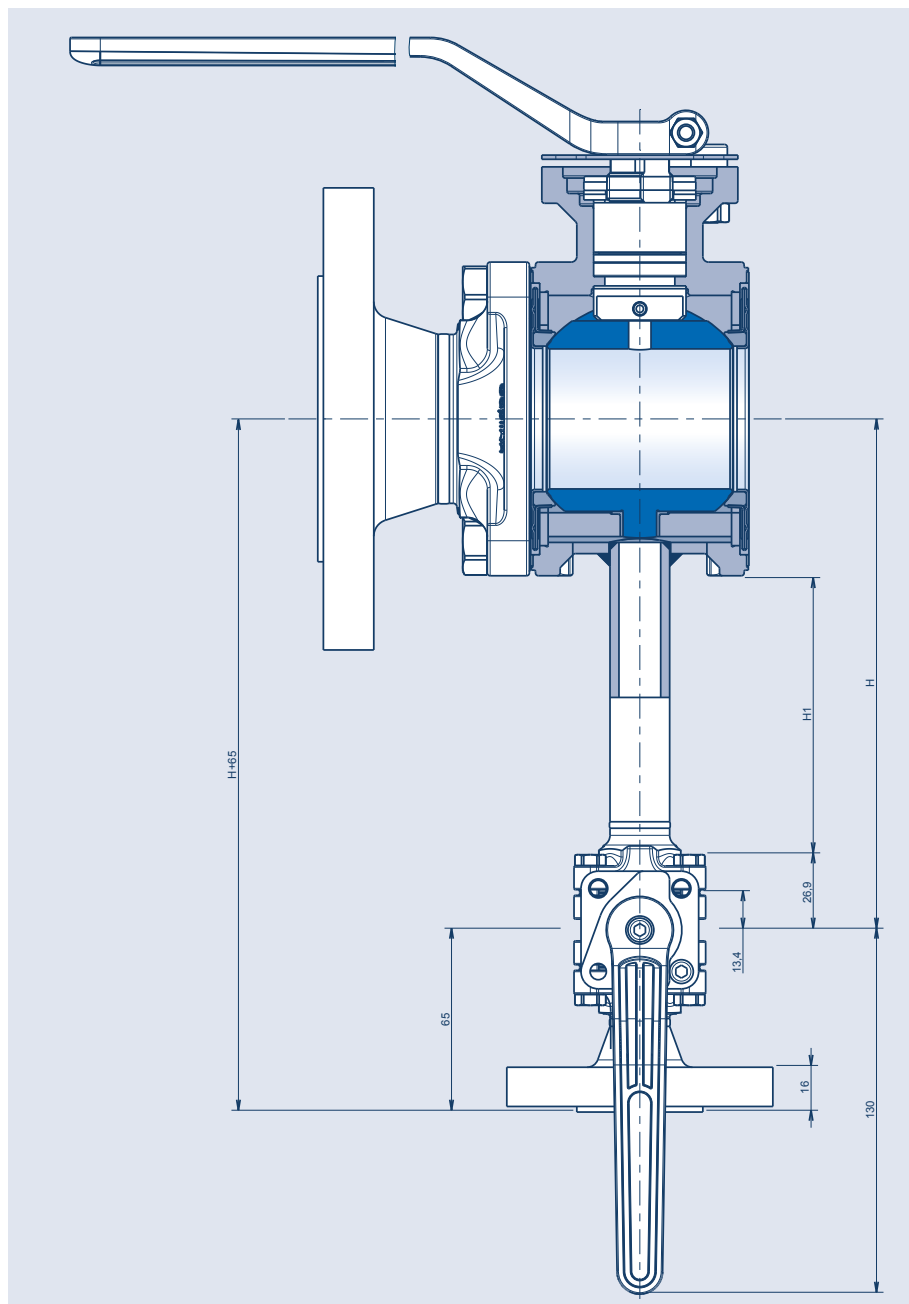

BALLOSTAR KHA-DBB

Pressure and temperature ranges

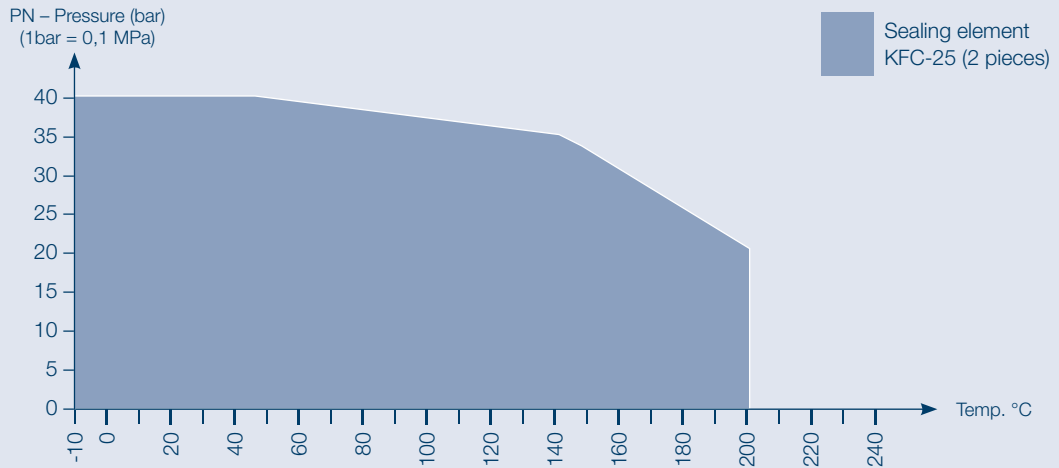

Applies to stainless and carbon steel

Operating moments for DBB 50-125

Nominal diameter DN		Differential pressure (bar)							
		0	5	10	16	20	25	30	40
inch	mm	Torque (Nm)							
1/2"	15	6	6	7	7	7	7	7	8
3/4"	20	12	12	12	12	12	13	13	14
1"	25	14	14	15	15	16	17	17	18
1 1/4"	32	17	17	17	18	19	20	22	23
1 1/2"	40	25	25	27	29	31	32	33	35
2"	50	16	19	25	28	29	33	38	43
2 1/2"	65	26	38	46	47	55	59	67	75
3"	80	38	43	60	68	75	80	89	125
4"	100	38	62	90	108	133	155	184	207
5"	125	150	184	225	319	372	403	419	465

Type overview

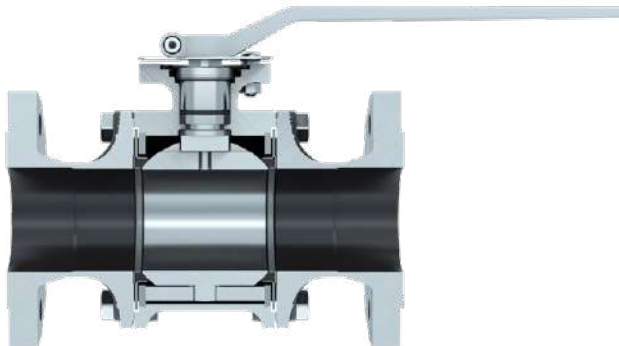

Trunnion mounted

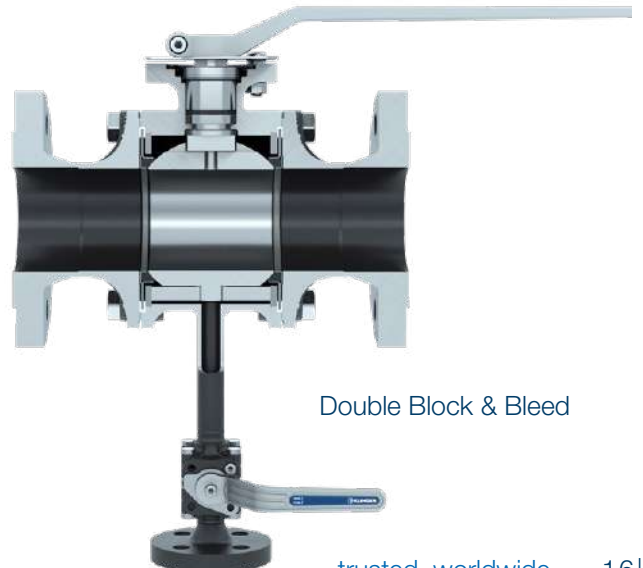

Double Block & Bleed

FULL POWER

Switch on and get going!

Both pneumatic and electromechanical actuators can be used for the automation of the KLINGER Ballostar KHA ball valve. The exact determination of the torque saves investment and follow-up costs. The actuator should therefore not be

selected in accordance with the maximum possible options in mind, but rather according to actual needs. In this context the necessary pressure differential determines the torque of the required actuator.

PNEUMATIC ACTUATOR

1. Limit switch box
2. Pneumatic actuator, single or double-acting
3. Solenoid valve
4. Bracket and coupling
5. KHA

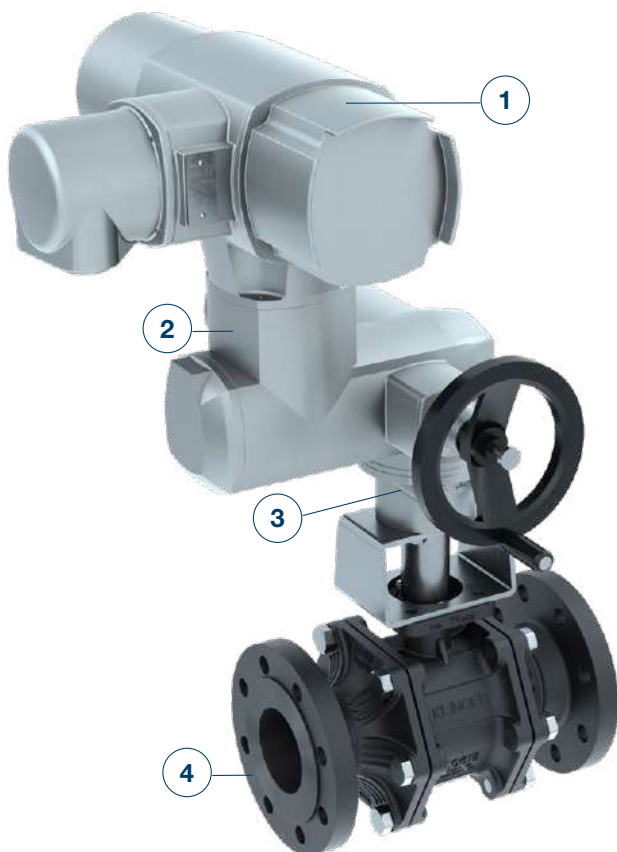
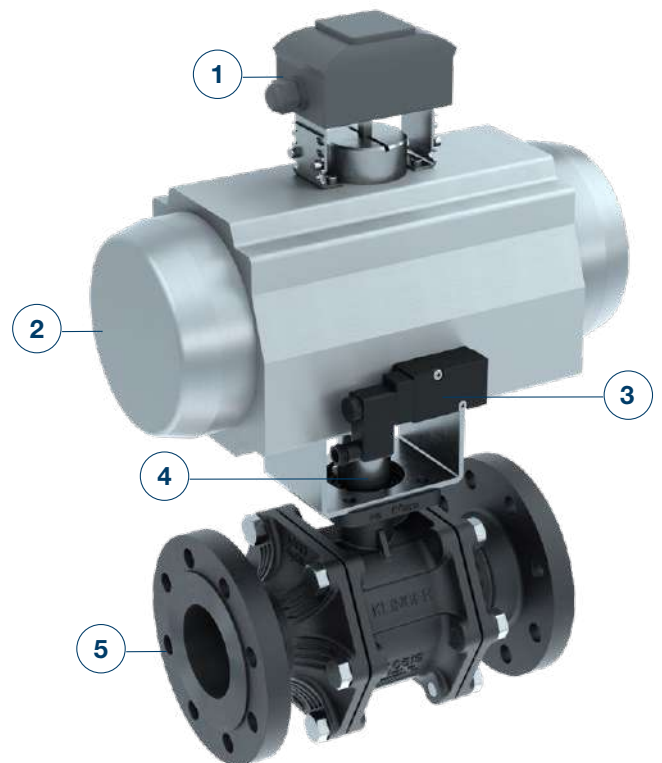

ELECTRIC ACTUATOR

1. Electric actuator
2. Actuator control
3. Bracket and coupling
4. KHA

ACTUATOR SELECTION

Operating moments for the different sealing elements

Nominal diameter DN		Differential pressure (bar)									
		0	5	10	16	20	25	30	40	50	63
inch	mm	Torque (Nm)									

Nominal diameter DN		Differential pressure (bar)			
		0	5	10	16
Inch	mm	Torque (Nm)			

KFC-25

½"	15	6	6	6	7	7	7	7	8	8	9	10
¾"	20	12	12	13	13	13	14	14	15	16	16	19
1"	25	14	15	16	17	18	19	20	22	24	27	
1 ¼"	32	17	18	20	22	23	24	26	28	31	35	
1 ½"	40	25	28	31	34	36	39	42	47	53	60	
2"	50	37	41	44	49	52	55	59	66			
2 ½"	65	60	66	73	80	85	91	98	110			
3"	80	96	114	132	154	168	186	204	240			
4"	100	160	184	208	236	255	279	303	350			
5"	125	270	318	365	422	460	508	555	650			

VITON

1"	25	14	15.9	17.8	20
1 ¼"	32	18	20.2	22.4	25
1 ½"	40	25	29.7	34.4	40
2"	50	40	49.4	58.8	70
2 ½"	65	55	72.2	89.4	110
3"	80	100	150	200	260
4"	100	160	219.4	278.8	350

PTFE

½"	15	5	6	6	6	6	6	6	7	7	8	9
¾"	20	11	11	11	12	12	12	13	13	14	15	17
1"	25	13	14	14	16	16	17	18	20	22	24	
1 ¼"	32	15	17	18	19	20	22	23	26	28	32	
1 ½"	40	21	24	26	29	31	33	35	40	45	51	
2"	50	30	33	36	40	42	45	48	54			
2 ½"	65	51	56	62	68	72	78	83	94			
3"	80	72	86	99	115	126	140	153	180			
4"	100	120	138	156	177	191	209	227	263			
5"	125	203	238	274	317	345	381	416	488			

KLINGER recommends the factor of 1.5 for standard calculations, meaning plus 50 % should be used.

For valves featuring a reduced bore, the previous row (i.e. the one with the smaller nominal diameter) should be used.

METAL/METAL SPECIAL

½"	15	8	8	8	9	9	9	9	10	11	12	14
¾"	20	15	16	16	17	18	19	19	21	22	24	29
1"	25	18	19	21	23	24	25	27	29	32	36	
1 ¼"	32	25	27	28	30	32	33	35	38	42	46	
1 ½"	40	40	45	50	55	59	64	69	78	88	100	
2"	50	55	64	74	85	93	102	111	130			
2 ½"	65	85	102	119	139	153	169	186	220			
3"	80	140	173	205	244	270	303	335	400			
4"	100	250	294	338	390	425	469	513	600			
5"	125	450	580	710	866	970	1100					

SPECIAL SOLUTIONS EXTENSIONS

Special challenges – special solutions!

In certain applications it may be necessary to employ so-called operating stem extensions for the valve: for example in the event of necessary protective and thermal insulation layers around the valve. Limited space may also be a reason for considering an extension, for example when the hand lever cannot be mounted directly on an ISO-top flange. Extensions are available – with or without a protective tube – at a standard length of 150 mm. The protective tube is fitted with an ISO-top flange at the end of the extension, allowing for subsequent gear or actuator mounting.

Special lengths available upon request.

Special features:

- » Standard length 150 mm
- » Protective tube material 1.4404
- » Operating stem material 1.4021 or special material on demand
- » Design featuring protective tube and ISO-top flange certified in accordance with EN ISO 5211

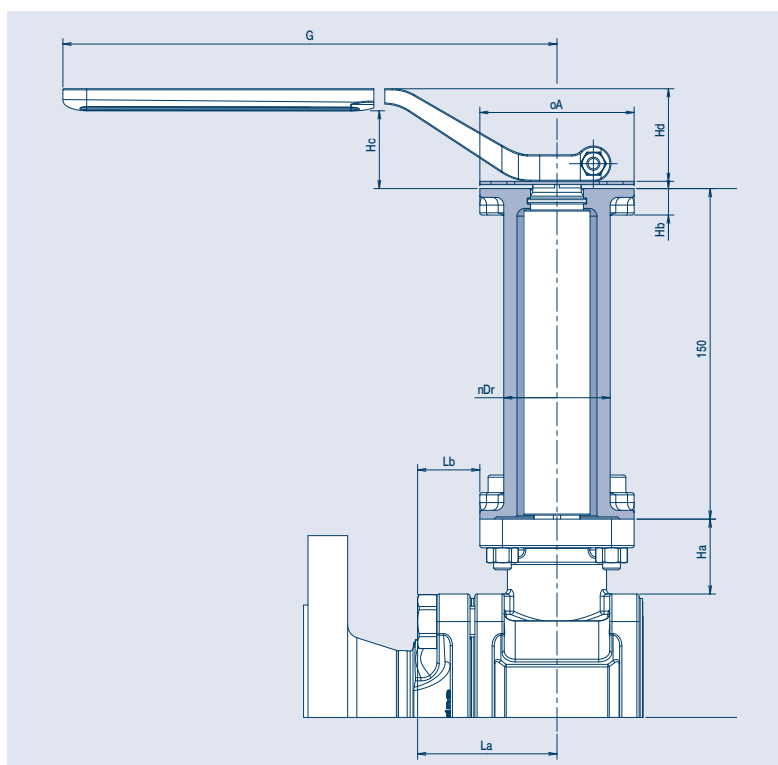

Nominal diameter	H	Ha	Hb	Hc	Hd	ØDr	A	La	Lb	G
DN15	185	11.5	6	38	48	30	42	26.9	5.9	130
DN20	196	16.2	6	38	48	30	42	34.3	13.3	130
DN25	200	17.5	6	38	48	30	42	36.3	15.3	130
DN32	215	25.0	8	34.5	42.5	38	50	43.8	18.8	252
DN40	222	23.5	8	34.5	42.5	38	50	51.9	26.9	252
DN50	240	34.0	12	36	46.2	48.3	70	63.3	28.3	310
DN65	250	29.5	12	36	46.2	48.3	70	69.5	34.5	310
DN80	272	36.5	14	31	43.5	60.3	102	83.4	32.4	500
DN100	285	34.0	14	31	43.5	60.3	102	98.0	47.0	500

FULLY IN CONTROL!

Control valve for regulated rate of flow

CONTROL VALVE

Control valves regulate the rate of flow.

Depending on the intended purpose of the system, the properties of a fluid medium can fluctuate in different ways: Temperature, pressure and fluid level are common variables in this context.

The control valve comprises three main components: **1) Valve, 2) Actuator and 3) Positioner.**

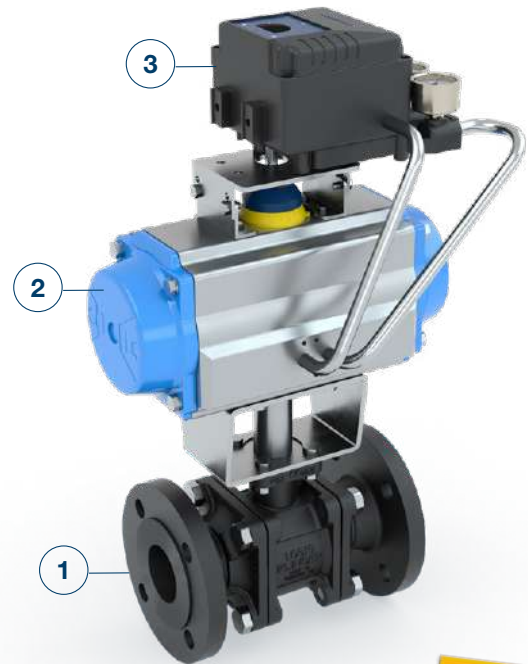

V-PORT BALL

For flow control and regulating applications, the ball valve model KHA is available with different v-port balls.

SPECIFICATIONS:

- » Different characteristic curves due to various ball cuttings
- » Applicable for clear media without solids
- » Easily combinable with pneumatic and electric control actuators
- » V-port ball versions are available with 10°, 30° and 60° angles as well as slotted
- » The V-port balls in the different cuttings are available for the full line size range of the ball valve model KHA

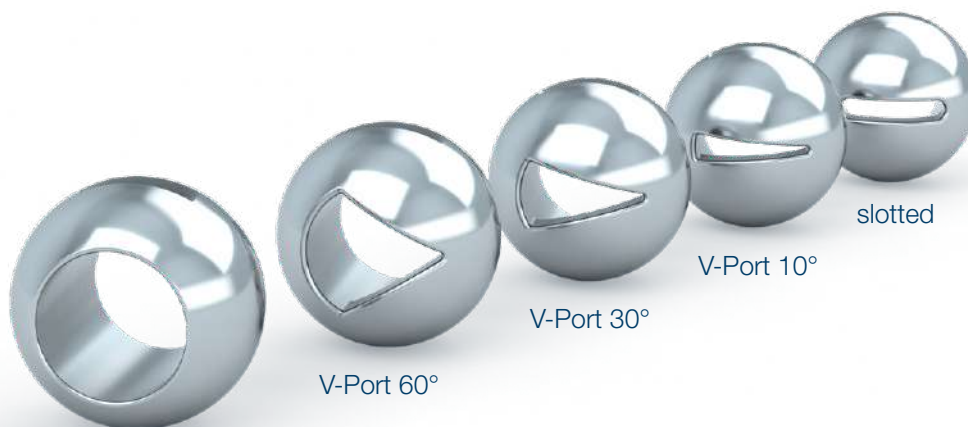

full bore

V-Port 60°

V-Port 30°

V-Port 10°

slotted

This V-cut gives this V-port ball valve its name. The size of the V-port regulates the flow rate – from full bore to sectioned 10°, 30° and 60° as well as slotted

AREAS OF UTILIZATION

Stuffing boxes

As a standard, the ball valves are fitted with the stuffing box Standard AF/GRA and the sealing element KFC-25. The remaining designs listed here can be optionally requested upon order. Special designs are supplied with a type rate.

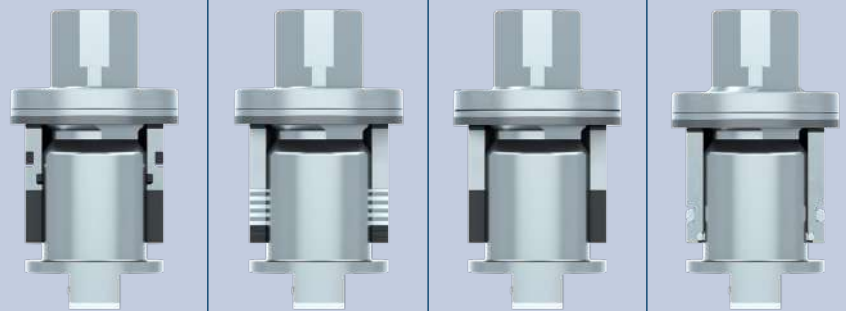

		FS Standard AF/GRA	LAB PTFE Labyrinth	GRA Graphite	VIT Viton
Media	Water / hot water	Recommended	Recommended	Recommended	Not recommended
	Mineral oil	Recommended	Recommended	Recommended	Recommended
	Heat-transfer oil	Not recommended	Not recommended	Recommended	Not recommended
	Liquid gas / 1) cryogenic temperature	Less suitable	Recommended	Not recommended	Not recommended
	Saturated steam	Recommended	Recommended	Less suitable	Not recommended
	Misc. gases	Recommended	Recommended	Recommended	Recommended
	Vacuum / full vacuum	Recommended	Recommended	Not recommended	Recommended
	Hot steam (max. 300 °C)	Less suitable	Not recommended	Recommended	Not recommended
	Oxygen	Recommended	Recommended		
	Operating conditions	Standard utilization	Recommended		
High number of cycles		Recommended	Recommended	Not recommended	Recommended
Frequent temperature changes		Recommended	Recommended	Recommended	Not recommended
Fire safety (Fire-Safe)		Recommended	Not recommended	Not recommended	Not recommended
Chemical industry		Recommended	Recommended	Recommended	Not recommended
Abrasive media		Recommended	Recommended	Recommended	Not recommended
Temperature range (°C)		-20 * +300	-196 +300	-85 +400	-15 +150
Certifications	VDI 2440 (TA-Luft)	+	+		+
	ÖVGW				
	Fire-Safe	+			

1) Combined with cryogenic temperature extension and sealing element

* O-rings for less temperature optionally available.

AREAS OF UTILIZATION

Pressure and temperature ranges

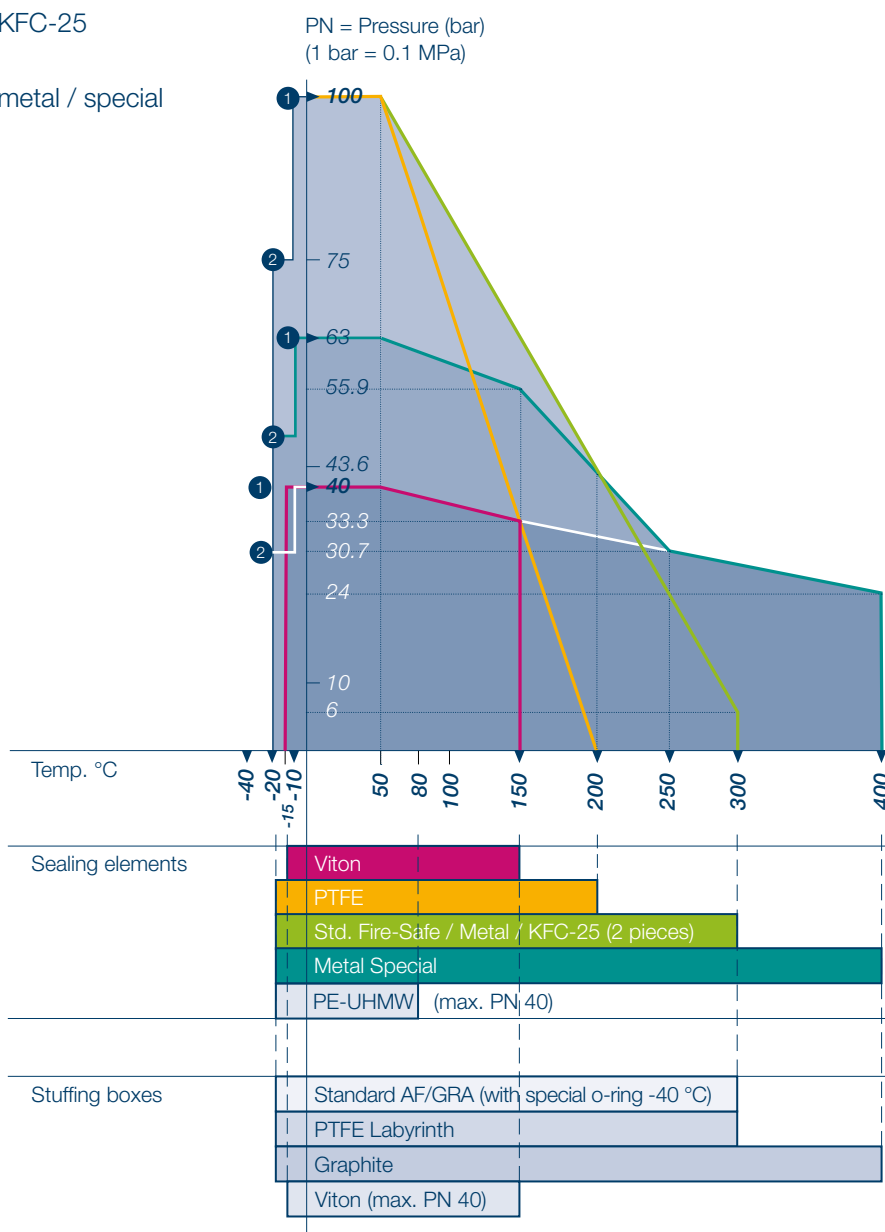
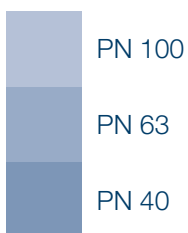

Steel cast iron

Material index VIII

The pt diagrams illustrate the influence of the three body materials, the sealing materials and the actuator shafts on the area of utilization of the ball valve. This represents safety at the highest level. Insert your operating point into the diagram fields and you will identify whether your

safety reserves meet your requirements. At the same time, you will see which parameters may require further change. Carrying out your selection on the basis of this principle, you will optimize the cost-effectiveness of your valve.

1 If the operating pressure is between 75 – 100 % of the nominal pressure, then the application field in all three pressure stages (PN 100, 63, 40) will reach down to -10 °C.

2 If the operating pressure, including load peaks, is between 25 – 75 %, the field of application increases to -20 °C in case of steel cast iron and to -60 °C in case of rust and acid-proof cast iron.

In case the operating pressure drops into the nominal pressure range, the application field within the temperature range will increase.

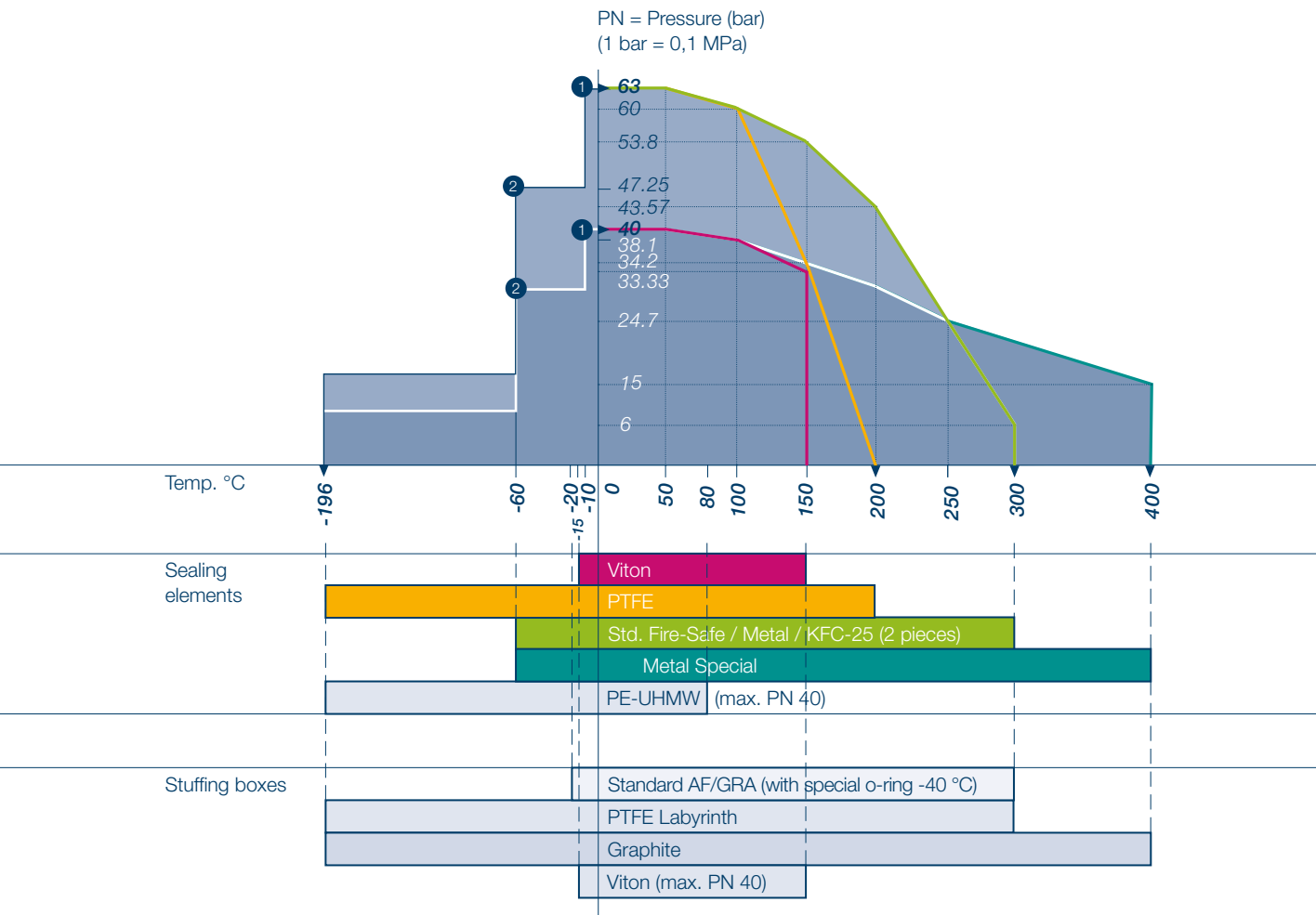

For application cases under -60 °C please contact the producer

rust and acid-proof cast iron

Material index VIII

TECHNICAL DETAILS

Flow characteristics for the determination
of the nominal diameter

SIZE OF BALL VALVE

Flow rate	Q	in m ³ /h
Pressure loss	Δp	in bar
Density	ρ	in kg/m ³
Velocity	w	in m/s
Flow coefficient	K_v	in m ³ /h
Pressure loss coefficient	ζ	

Allows for the calculation of:

$$K_v = Q * \sqrt{\frac{\rho}{1000 * \Delta p}}$$

The valve is to be selected in a manner that the K_v-value is greater, or the ζ-value less than the computed value.

or

$$\zeta = \frac{2 * \Delta p * 10^5}{\rho * w^2}$$

FLOW VALUES

DN (mm)	ζ	K _{vs} -value
15	0.24	18.3
20	0.21	35.2
25	0.19	56.7
32	0.22	88.1
40	0.14	173.0
50	0.09	329.0
65	0.09	560.5
80	0.08	910.0
100	0.07	1522.0
125	0.06	2537.0

The characteristic unit for shut-off and control valves is the K_v-value. The values provided in the table apply to a H₂O flow medium with a temperature of 5 – 30 °C, a density of 1000 kg/ m³ and a pressure loss of p = 1 bar at the valve.

In metric measurement systems the characteristic unit utilized is the K_v-value. In countries using inches, the characteristic unit is described by means of the cV-value. It provides how many US gal/min of water, at a temperature of 60 °F and with a pressure loss of 1 psi, flow through the valve.

PRESSURE LOSSES

$$\Delta p = \zeta * \frac{\rho}{2} * w^2 * 10^{-5}$$

oder

$$\Delta p = \left(\frac{Q}{k_v}\right)^2 * \frac{\rho}{1000}$$

TECHNICAL DETAILS

Bill of materials

PARTS LIST

Pos.	Quantity	Name	Material	Material
1	1	Housing	1.0619	1.4408
2	1	Operating shaft	1.4104	1.4404
3	1	Ball		V4A
4	2	Sealing ring		KFC-25
5	2	Holding disk		1.4462
6	4	Gasket		Graphite
7	2	Bearing disc		Peek
8	1	Sealing bush		Graphite
9	1	Sealing insert		1.4401
10	1	O-Ring		FEPM A75H
11	1	O-Ring		FEPM A75H
12	1	Washer		1.4401
13	1	Washer		1.4404
14	1	Belleville washer		1.4310
15	1	Gland nut		1.4404
16	2	Gasket		KLINGERSIL® C-4430
17	2	Flange cap	1.0619/1.0345	1.4408/1.4404
17	2	Welding ends	1.0619/1.0345	1.4408/1.4404
17	2	Threaded connection	1.0619/1.0345	1.4408/1.4404
18	8/12/16	Hexagon nut		A4
19	1	Socket screw		A4

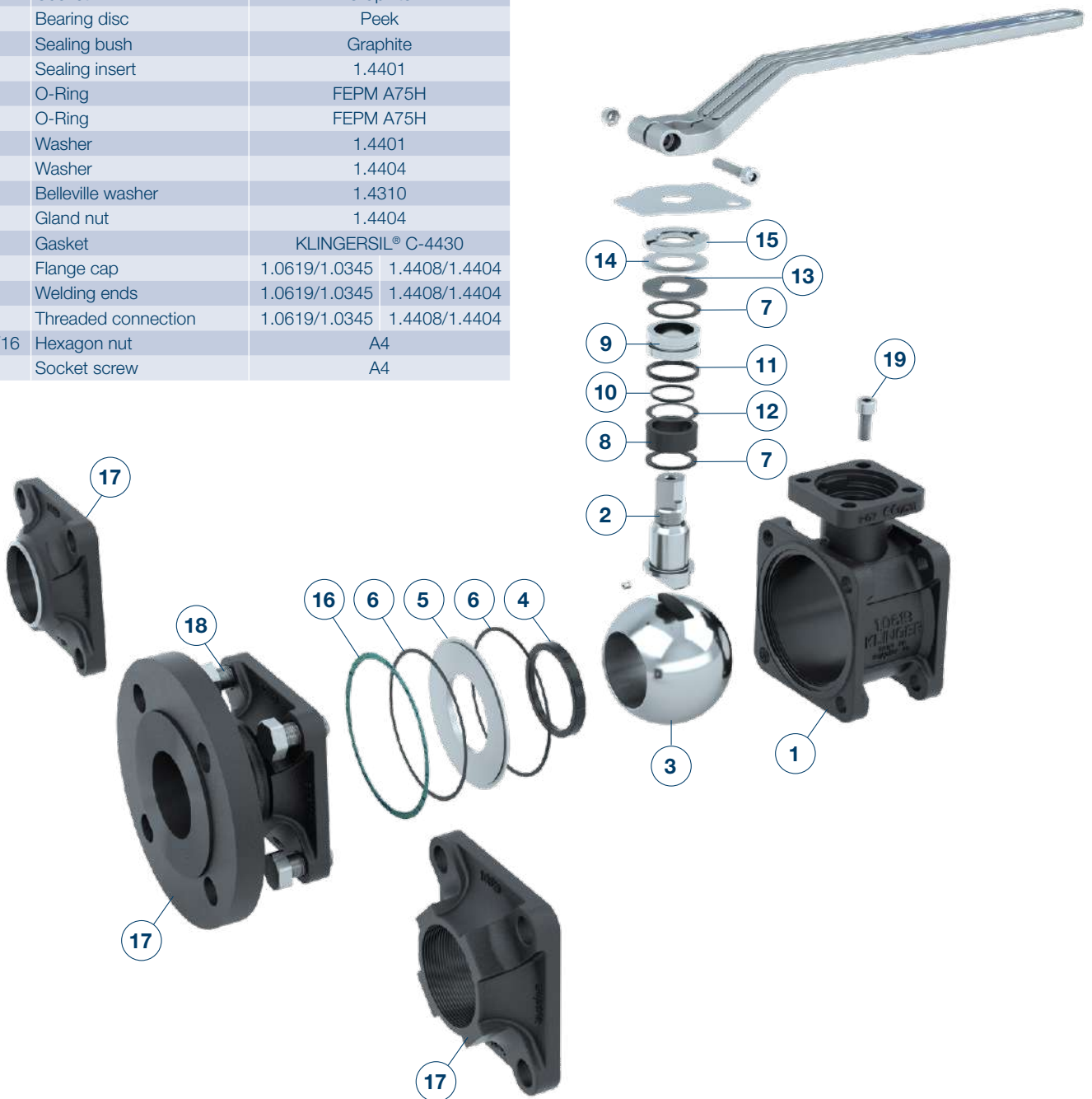



Klinger Portugal, Lda.
Via José Régio, 36
Centro Empresarial Vilar do Pinheiro
4485-860 Vila do Conde
T: +351 22 947 0910
E-mail: geral@klinger.pt