

# RR FLAP GATE

The RR flap gate is a round shaped gate designed for discharge lines such as levees, sewer lines and drainage conduits, when closed preventing back-flow and opening automatically when the unseating water head is higher than the seating water head

## Product description:

- Size range of d150 up to d2000
- Seating head pressure of 5 m.w.c
- Stainless steel fabricated construction. Different stainless steel grades available
- Opening and closing by seating and unseating head differential pressure. Hydraulic actuators available for fast opening applications (i.e.: storm tanks)
- Designed according to DIN 19569

## Features:

- Double pivoting arm to allow proper flap seating and tight sealing
- Self-adjusting lip EPDM seal design ensuring watertight performance even with low seating water heads
- Mounting options: wall mount, wall thimble mount or standard flange mount
- Leakage rate as per DIN 19569-4 Class 3

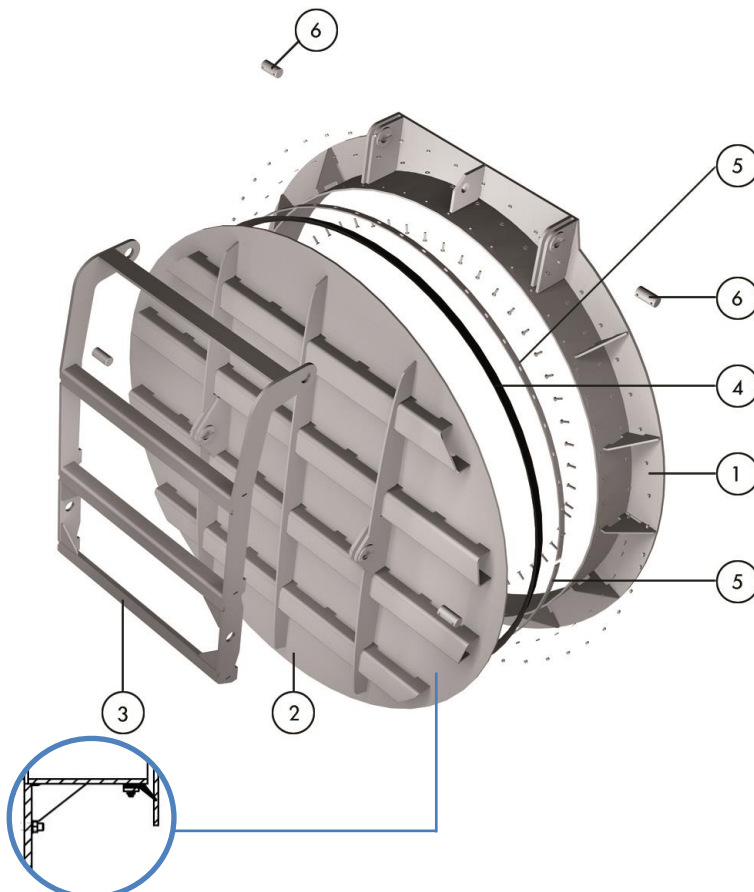

## STANDARD MATERIAL OF CONSTRUCTION

| ITEM | DESCRIPTION   | MATERIAL              |
|------|---------------|-----------------------|
| 1    | Frame         | AISI 304L / AISI 316L |
| 2    | Flap          | AISI 304L / AISI 316L |
| 3    | Pivot Arm     | AISI 304L / AISI 316L |
| 4    | Seal          | EPDM                  |
| 5    | Seal Retainer | AISI 304L / AISI 316L |
| 6    | Hinge Pin     | AISI 304L / AISI 316L |

# RR FLAP GATE

## DIMENSIONS

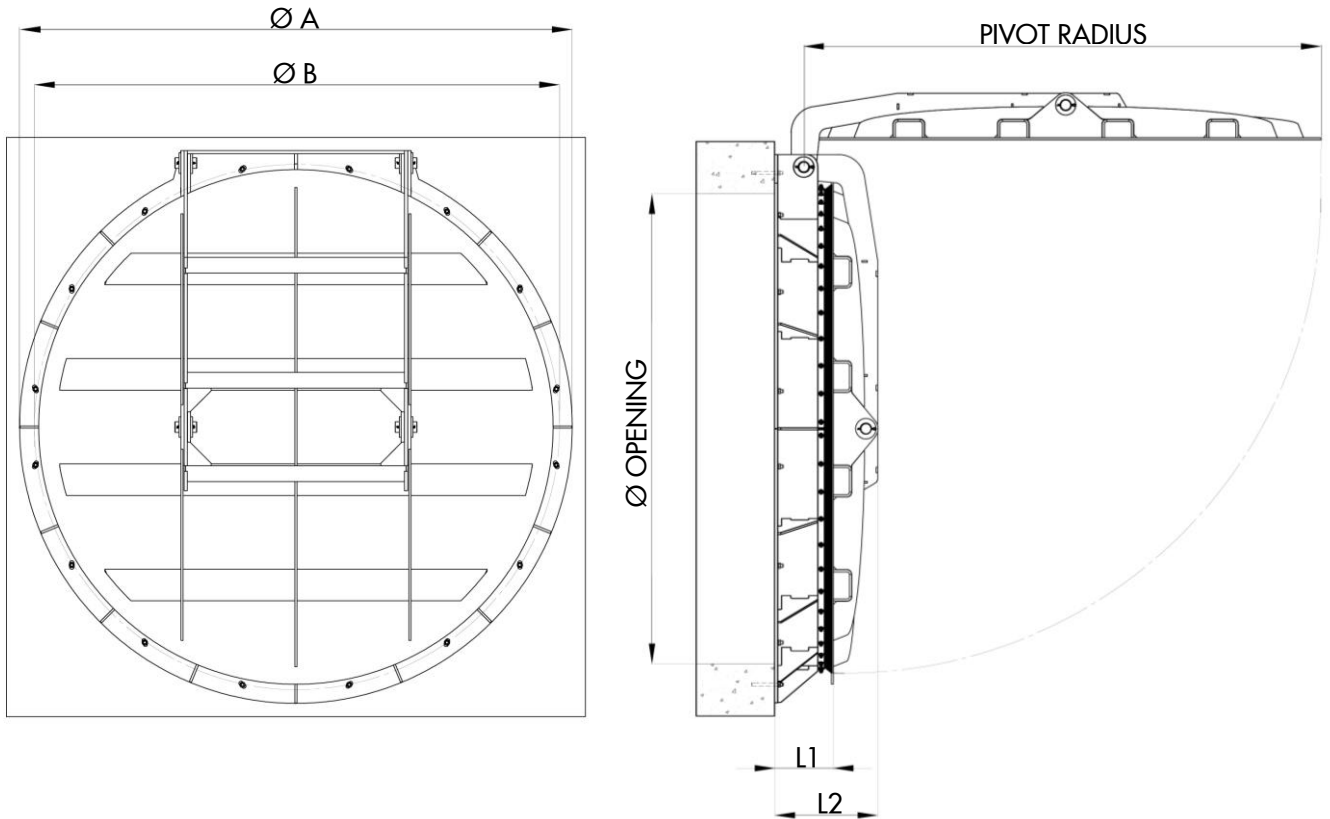

| SIZE (mm)<br>Opening Diameter | A    | B    | L1  | L2  | PIVOT RADIUS |
|-------------------------------|------|------|-----|-----|--------------|
| 150                           | 285  | 235  | 105 | 158 | 267          |
| 200                           | 340  | 290  | 105 | 158 | 316          |
| 300                           | 445  | 395  | 105 | 158 | 415          |
| 400                           | 565  | 515  | 106 | 158 | 514          |
| 500                           | 670  | 620  | 106 | 158 | 614          |
| 600                           | 780  | 730  | 106 | 184 | 714          |
| 700                           | 895  | 845  | 106 | 184 | 814          |
| 800                           | 1015 | 965  | 106 | 184 | 913          |
| 900                           | 1115 | 1065 | 106 | 212 | 1013         |
| 1000                          | 1215 | 1165 | 106 | 212 | 1113         |
| 1100                          | 1315 | 1265 | 106 | 212 | 1213         |
| 1200                          | 1455 | 1405 | 117 | 212 | 1313         |
| 1300                          | 1560 | 1510 | 123 | 212 | 1413         |
| 1400                          | 1625 | 1625 | 148 | 212 | 1513         |
| 1500                          | 1815 | 1760 | 148 | 288 | 1625         |
| 2000                          | 2325 | 2230 | 220 | 398 | 2185         |

These dimensions are only for information only.  
Do not use for installation or submittal purposes