

# MU PENSTOCK STANDARD RANGE

## 1300 x 1300 - 1500 x 2000

The MU model penstock is a four-side sealing wall-mounted penstock suitable for different type of applications in the water and waste water treatment plants, pumping stations, storm tanks, desalination plants, irrigation, dams and reservoirs, etc.

### Product description:

- Bi-directional as standard
- Size range of 1300x1300 up to 1500x2000
- Seating head pressure of 6 mwc and unseating head pressure of 4 mwc
- Stainless steel fabricated construction. Different stainless steel grades available
- Rising & non-rising stem configurations available
- Manual (handwheel and bevel gear), pneumatic (single and double-acting), electric and hydraulic actuation options available
- Designed according to DIN 19569. Design as per AWWA C561 or BS 7775 also available

### Features:

- Open frame (rising stem) and self-contained (non rising stem) configurations. Modular design with common basic structure and kits for rising and non rising stem configurations
- Self-cleaning HMWPE gate guides for low friction during operation, minimizing thrust and maximizing seal life
- Self-adjusting double-lip EPDM seal design, wedges are not required thus resulting in a lower torque requirement
- Yoke or pedestal mounted actuators. Inclined, straight and straight-on-bracket pedestals available
- Stem extensions for high operating floor levels, including the required stem guides
- Mounting options: standard wall mount, also thimble mount
- Flush bottom design which can be made both elevated and flush bottom installation
- Leakage rate as per DIN 19569-4 Class 5 (1,2 l/min per meter)

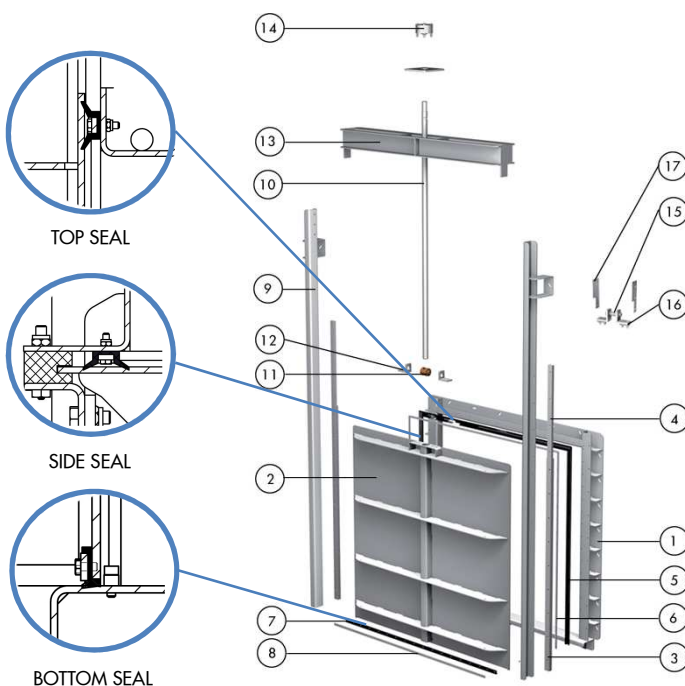

### STANDARD MATERIAL OF CONSTRUCTION

ITEM	DESCRIPTION	MATERIAL (standard)
1	Frame	AISI 304L / AISI 316L
2	Slide	AISI 304L / AISI 316L
3	Guides	Polyethylene (HMWPE)
4	Guide extension	Polyethylene (HMWPE)
5	Seal	EPDM
6	Seal Retainer	AISI 304L / AISI 316L
7	Bottom Seal	EPDM
8	Bottom Seal Retainer	AISI 304L / AISI 316L
9	Frame Guide	AISI 304L / AISI 316L
10	NRS Kit - Stem	Stainless Steel
11	NRS Kit - Stem Nut	Bronze
12	NRS Kit - Stem Nut Bracket	AISI 304L / AISI 316L
13	NRS Kit - Yoke	AISI 304L / AISI 316L
14	NRS Kit - Stem Coupling	AISI 304L / AISI 316L
15	RS Kit - Pin	AISI 304L / AISI 316L
16	RS Kit - Gate coupling bracket	AISI 304L / AISI 316L
17	RS Kit - End stop	AISI 304L / AISI 316L

# MU PENSTOCK STANDARD RANGE

## 1300 x 1300 - 1500 x 2000

### RISING STEM

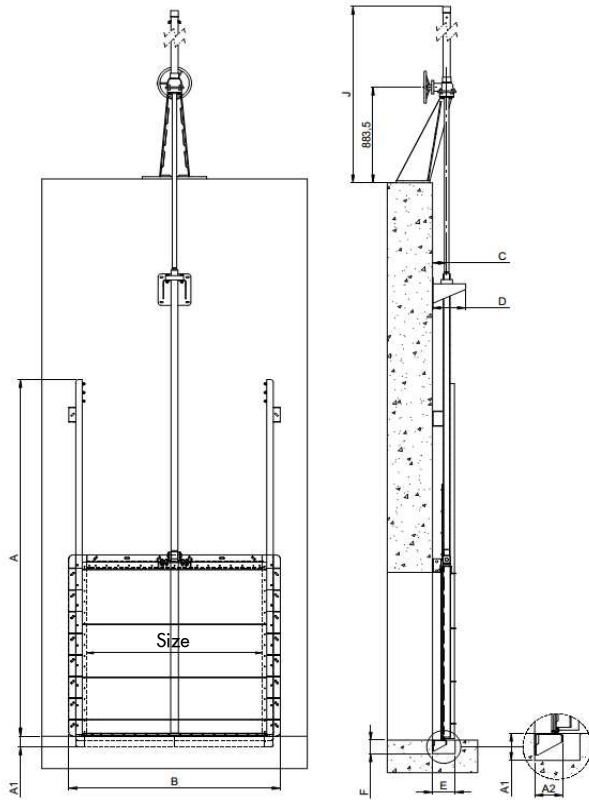

### NON RISING STEM

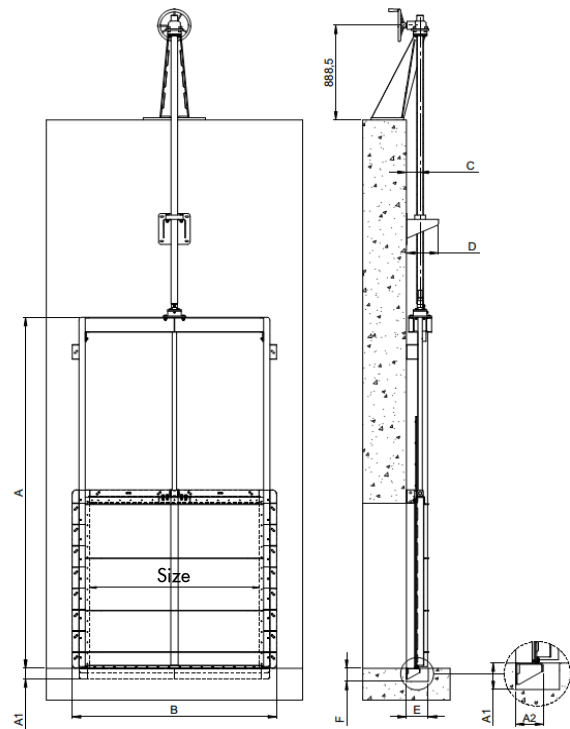

### RISING STEM

SIZE (mm) Opening	A	B	A1	A2	C	D	J	E x F
1300 x 1300	2795	1624	100	125	126	295	2450	200 x 125
1400 x 1400	2995	1724	100	125	126	295	2550	200 x 125
1500 x 1500	3195	1824	100	125	126	295	2650	200 x 125
1500 x 1600	3395	1824	100	125	126	295	2750	200 x 125
1500 x 1700	3595	1824	100	125	126	295	2850	200 x 125
1500 x 1800	3795	1824	100	125	126	295	2950	200 x 125
1500 x 1900	3995	1824	100	125	126	295	3050	200 x 125
1500 x 2000	4195	1824	100	125	126	295	3150	200 x 125

### NON RISING STEM

SIZE (mm) Opening	A	B	A1	A2	C	D	J	E x F
1300 x 1300	2795	1624	100	125	126	295	-	200 x 125
1400 x 1400	2995	1724	100	125	126	295	-	200 x 125
1500 x 1500	3195	1824	100	125	126	295	-	200 x 125
1500 x 1600	3395	1824	100	125	126	295	-	200 x 125
1500 x 1700	3595	1824	100	125	126	295	-	200 x 125
1500 x 1800	3795	1824	100	125	126	295	-	200 x 125
1500 x 1900	3995	1824	100	125	126	295	-	200 x 125
1500 x 2000	4195	1824	100	125	126	295	-	200 x 125

NOTE: These dimensions are only for reference. Do not use for installation or submittal purposes. For dimensions other than above, please contact US.