

The CC channel gate is a three-side sealing penstock designed for open channel installations and suitable for different type of applications in the water and waste water treatment plants, irrigation, dams and reservoirs, etc.

Product description:

- Usually bi-directional, also available uni-directional
- Size range of 200x200 up to 3500x3500 (larger sizes on request)
- Seating and unseating head pressure of slide height
- Stainless steel fabricated construction.
Different stainless steel grades available
- Rising & non-rising stem configurations available
- Manual (handwheel and bevel gear), pneumatic (single and double-acting), electric and hydraulic actuation options available
- Designed according to DIN 19569. In general accordance with AWWA C561 or BS 7775 also available

Features:

- Close- frame configurations with intermediate reinforcing yokes in large size channel gates
- HMWPE gate guides for low friction during operation, minimizing thrust and maximizing seal life
- Self-adjusting lip EPDM seal design, wedges are not required thus resulting in a lower torque requirement
- Yoke mounted actuators
- Mounting options: usually embedded in concrete, also face-mounted in existing channel and wall mounted at the end of the channel
- Flush bottom design
- Leakage rate as per DIN 19569-4 Class 5 (1,2 l/min per meter)

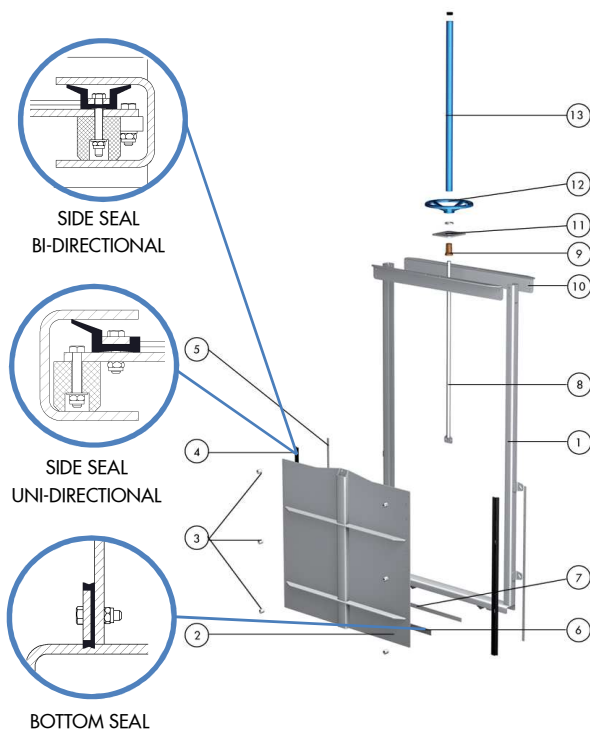

STANDARD MATERIAL OF CONSTRUCTION

ITEM	DESCRIPTION	MATERIAL (standard)
1	Frame	AISI 304L / AISI 316L
2	Slide	AISI 304L / AISI 316L
3	Guides	Polyethylene (HMWPE)
4	Seal	EPDM
5	Seal Retainer	AISI 304L / AISI 316L
6	Bottom Seal	EPDM
7	Bottom Seal Retainer	AISI 304L / AISI 316L
8	Stem	Stainless Steel
9	Stem Nut	Bronze
10	Yoke	AISI 304L / AISI 316L
11	Stem Nut Bracket	AISI 304L / AISI 316L
12	Handwheel	Cast Iron (RS) / Aluminum (NRS)
13	Stem Protector	Carbon Steel / Clear Polycarbonate (RS)

RISING STEM

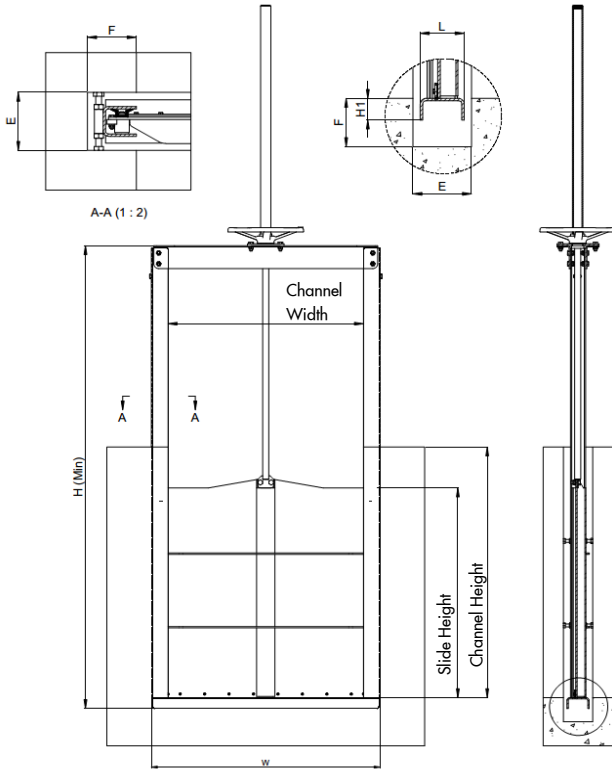

NON RISING STEM

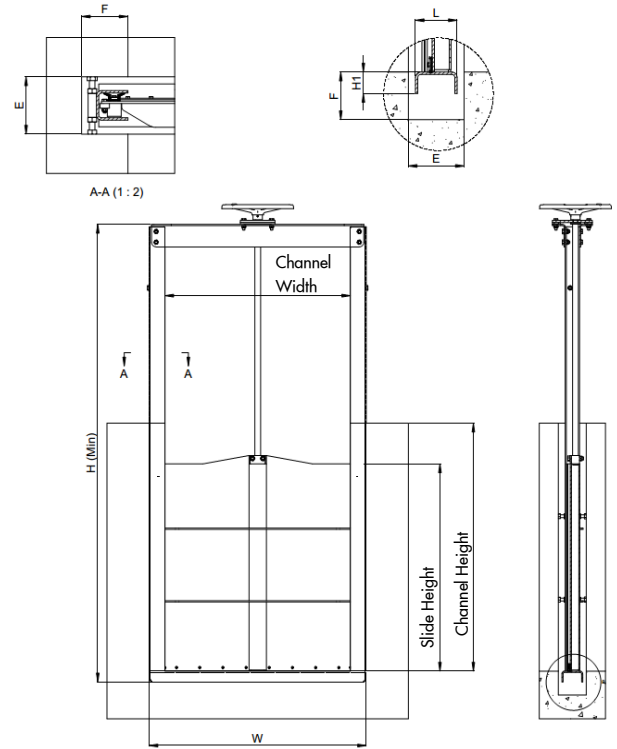

SIZE (mm) Channel Width	SIZE (mm) Channel Height	W	H Min	L	H1	E x F
150	150	284	425	80	30	120 x 100
200	200	334	525	80	30	120 x 100
300	300	434	725	80	30	120 x 100
400	400	534	925	80	30	120 x 100
500	500	634	1125	80	30	120 x 100
600	600	736	1380	90	45	120 x 100
700	700	836	1580	90	45	120 x 100
800	800	936	1780	90	45	120 x 100
900	900	1036	1980	90	45	120 x 100
1000	1000	1136	2180	90	45	120 x 100
1100	1100	1236	2415	110	60	250 x 125
1200	1200	1336	2615	110	60	250 x 125
1300	1300	1436	2815	110	60	250 x 125
1400	1400	1536	3015	110	60	250 x 125
1500	1500	1636	3215	110	60	250 x 125
1600	1600	1774	3500	215	90	250 x 125
1700	1700	1874	3700	215	90	250 x 125
1800	1800	1974	3900	215	90	250 x 125
1900	1900	2074	4100	215	90	250 x 125
2000	2000	2174	4300	215	90	250 x 125

Above sizes and dimensions for bidirectional channel gates embedded in concrete

NOTE:

These dimensions are only for reference. Do not use for installation or submittal purposes.

For dimensions or mounting positions other than those indicated above, please contact us.