

WG

KNIFE GATE VALVE

The WG model knife gate valve is a full flanged heavy duty valve equipped with two metal reinforced rubber sleeves designed for use in the handling of abrasive slurries, mainly in industries such as Mining, Chemical Plants, Power Plants, Wastewater Treatment Plants, etc.

Product description:

- Bi-directional full flanged heavy duty knife gate valve
- Size range of DN80-900 (larger sizes available). See Dimension Charts for pressure rating
- Rising stem
- Standard flange connection: EN 1092 PN10 and ASME B16.5 (class 150)
Others available upon request
- Manual (handwheel and bevel gear), pneumatic (single and double-acting), electric and hydraulic actuation options available
- For EU Directives and other Certificates, please see the document: Directives and Certificates Compliance - Knife Gate Valves - Catalogues and Datasheets

Features:

- Full flange cast monoblock body with two machined lateral mouths where the sleeves fit perfectly and grease nipples to lubricate the gate
- Open at the bottom for draining purposes, also available with covers or splash guards
- Rectangular shaped stainless steel gate, polished both sides to reduce friction and avoid seat damage
- Metal reinforced rubber sleeve seats, designed to allow maximum flexibility and minimum effort during gate travel
- EPDM packing as standard. Conventional leak proof packing also available
- RAL-5015 blue epoxy-coating on all cast iron/carbon steel components
- Automated valves provided with gate guards in accordance with EU Safety Standards
- Other options: open-closed lockout system, flush ports, special materials, fabricated valves, gate coatings, etc.
- Actuation accessories: limit & proximity switches, mechanical stops, solenoid valves, manual overrides, fail safe systems, stem extensions and floor stands

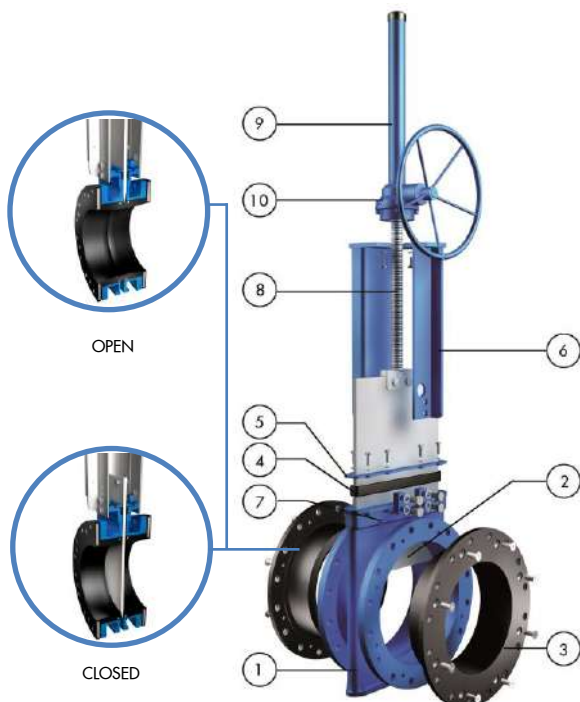

STANDARD PARTS LIST

Part	Materials
1 Body	Ductile iron A536 (60-40-18) / 0.7040 / GJS 400
2 Gate	AISI 304 (1.4301) / AISI 316 (1.4401)
3 Sleeves	Natural rubber/ EPDM
4 Packing	EPDM
5 Gland Follower	A570 GR.40 / 1.0044 Epoxy coated
6 Yoke	A570 GR.40 / 1.0044 Epoxy coated
7 Grease Nipple	Zinc coated carbon-steel
8 Stem	Stainless Steel
9 Stem Protector	A570 GR.40 / 1.0044 Epoxy coated
10 Bevel Gear	-

WG

KNIFE GATE VALVE

DIMENSIONS (mm) Hand Operated Rising Stem

DN	Pressure	A1*	A2*	B	C	D	E	F	ØG	H	J	K	ØP	ØI	
80	10 bar	-	175	183	179	100	124	177	47	225	495	96	-	72	62
100	10 bar	-	175	183	171	107	140	193	67	310	645	115	-	100	85
150	10 bar	-	178	186	238	107	175	259	67	310	745	141	-	148	137
200	10 bar	FL0.4	184	192	295	165	205	315	109	300	1040	173	200	197	175
250	10 bar	FL0.4	225,5	233	346	185	245	389	84	300	1060	204	200	250	230
300	10 bar	FL0.4	257	264	395	250	280	446	84	300	1460	244	200	292	273
350	10 bar	FL0.4	257	264	450	250	325	501	84	450	1530	268	220	337	318
400	10 bar	FL0.4	279,5	287	511	270	350	558	84	450	1640	300	220	375	356
450	6-10 bar ⁽¹⁾	FL1.6	311	319	564	290	420	625	84	450	1750	320	220	425	378
500	6-10 bar ⁽¹⁾	FL1.6	359	367	623	290	462	686	102	650	1930	359	288	470	420
600	6-10 bar ⁽¹⁾	FL1.6	371,5	380	730	290	510	780	102	650	2425	422	288	585	539
750	5-10 bar ⁽¹⁾	FL1.6	395,5	405	911	320	600	985	102	650	2730	532	288	737	680
900	5-10 bar ⁽¹⁾	FL1.6	470	480	1084	320	700	1165	102	650	3010	633	288	889	810

A1*: installed face to face

A2*: minimum required dimension for installation

⁽¹⁾ Duplex gate for 10 bar

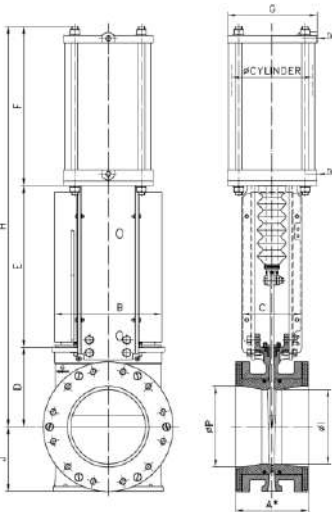
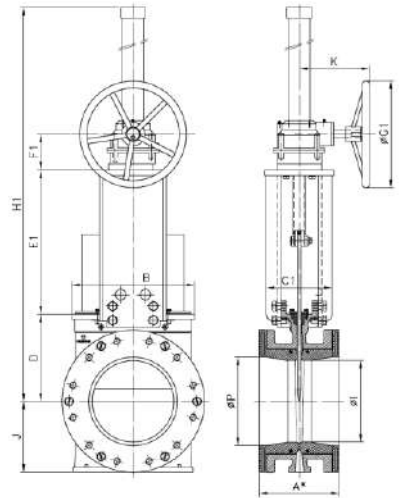

DIMENSIONS (mm) Pneumatic Actuator (D/A)

DN	Pressure	A1*	A2*	B	C	D	E	F	G	H	J	ØP	ØI	Standard Cyl.	TM
80	10 bar	175	183	179	100	124	257	240	140	621	96	72	62	C125/110	1/4"
100	10 bar	175	183	171	107	140	270	258	140	668	115	100	85	C125/130	1/4"
150	10 bar	178	186	238	107	175	395	323	175	893	141	148	137	C160/185	1/4"
200	10 bar	184	192	291	165	205	464	398	220	1067	173	197	175	C200/240	3/8"
250	10 bar	225,5	233	346	185	245	505	470	277	1220	204	250	230	C250/290	3/8"
300	10 bar	257	264	398	250	280	650	538	335	1474	244	292	273	C300/345	1/2"
350	10 bar	257	264	450	290	325	712	650	444	1687	268	337	318	C350/395	3/4"
400	10 bar	279,5	287	511	290	350	769	705	444	1824	300	375	356	C350/450	3/4"
450	6-10 bar ⁽¹⁾	311	319	564	290	420	838	767	515	2025	320	425	378	C400/500	3/4"
500	6-10 bar ⁽¹⁾	359	367	623	290	462	897	839	515	2198	359	470	420	C400/560	3/4"
600	6-10 bar ⁽¹⁾	371,5	380	730	290	510	990	921	515	2420	422	585	539	C400/655	3/4"

A1*: installed face to face

A2*: minimum required dimension for installation

⁽¹⁾ Duplex gate for 10 bar

DIMENSIONS (mm) Electric Actuator Rising Stem

DN	Pressure	A1*	A2*	B	C	D	E	F	ØG	H	J	K	L	M	N	ØP	ØI
80	10 bar	175	183	179	100	124	185	143	160	662	96	265	62	238	249	72	62
100	10 bar	175	183	171	107	140	195	143	160	688	115	265	62	238	249	100	85
150	10 bar	178	186	238	107	175	260	143	160	1158	141	265	62	238	249	148	137
200	10 bar	184	192	291	165	205	330	155	200	1272	173	283	65	248	254	197	175
250	10 bar	225,5	233	346	185	245	405	155	200	1387	204	283	65	248	254	250	230
300	10 bar	257	264	398	250	280	462	155	200	1454	244	283	65	248	254	292	273
350	10 bar	257	264	450	290	325	520	158	315	1602	268	389	90	286	336	337	318
400	10 bar	279,5	287	511	290	350	580	158	315	1690	300	389	90	286	336	375	356
450	6-10 bar ⁽¹⁾	311	319	564	290	420	645	158	409	1822	320	389	90	286	336	425	378
500	6-10 bar ⁽¹⁾	359	367	623	290	462	705	158	400	1925	359	389	90	286	339	470	420
600	6-10 bar ⁽¹⁾	371,5	380	730	290	510	804	158	500	2120	422	430	115	303	365	585	539
750	5-10 bar ⁽¹⁾	395,5	405	911	320	600	967	190	500	2880	532	430	115	303	365	737	680
900	5-10 bar ⁽¹⁾	470	480	1084	320	700	1170	190	500	3180	633	430	115	303	365	889	810

A1*: installed face to face

A2*: minimum required dimension for installation

⁽¹⁾ Duplex gate for 10 bar

