

Flow rate

- Up to 7.6 l/h

Pressure

- Up to 17.3 bar

Liquid ends

- Acrylic, stainless steel, PP, PVC, PVDF, designed for viscous products, designed for degassing products

LCD user interface

with display of the calculated flow rate



Excel™ AD

Electromagnetic dosing pump

- **User interface:** easy reading and setup via an LCD screen
- **Can be adapted to suit numerous applications and processes**
- **Quick installation and commissioning**

TYPICAL APPLICATIONS

- **Domestic hot water treatment:** disinfection of systems (injection of disinfectant) and water conditioning (injection of scale inhibitor or corrosion inhibitor)
- **Cooling water treatment:** protection of cooling circuits (injection of corrosion inhibitor, non-oxidising biocide, anti-foaming agent), disinfection (injection of sodium hypochlorite - AutoPrime™ liquid ends)
- **Municipal water treatment:** proportional injection of chemical products, pH regulation (injection of acids/alkalis)
- **Sludge treatment:** sludge thickening and dewatering (injection of liquid polymers - high viscosity liquid ends)
- **Livestock farming:** vaccination/medical treatment via drinking water (injection of medicines, vitamins or vaccines); reduction of health problems by acidification of the drinking water and (or) feedstuffs in mashing machines (injection of formic, fumaric or citric acid); disinfection of water (chlorine dosing), and cleaning and disinfection of tubing (dosing of hydrogen peroxide and chlorine dioxide)
- **All industries:** filling processes, continuous dosing processes, automated processes

FEATURES AND BENEFITS

- **Easy to use:** the (calculated) dosing rate is displayed directly in l/h or GPH
- **Fully compatible with most chemicals used:** liquid ends available in 5 different materials
- **Can be adapted to suit the process:** control can be manual, by pulse, by 4-20 mA signal, sequential via timer, batch injection, pulse division/multiplication, 24 VDC output, remote on/off
- **Wide injection range:** stroke frequency adjustable from 1 to 59 strokes/h and from 1 to 120 strokes/min; stroke length adjustable from 20% to 100% (50% to 100% recommended for AutoPrime™ liquid ends)
- **Display of the pump status:** LED operating indicator and operating/fault alarm
- **High pumping capacity:** double ball check valves
- **Dosing of products requiring continuous automatic degassing:** AutoPrime™ liquid end
- **Dosing of high viscosity products:** High Viscosity liquid end
- **Monitoring of product transfer operations:** single or dual level switch available as an option
- **2-year warranty**

Technical features

Materials/Construction of liquid ends and connections

- **Liquid ends:** acrylic, 316 stainless steel, PP, PVC, PVDF
- **Liquid ends for viscous products**
- **AutoPrime™ liquid ends** for degassing products requiring automatic degassing
- **Priming bleed** integrated in the liquid ends
- **Balls:** ceramic, PTFE or 316 stainless steel
- **Connections available:** metric or imperial low density polyethylene (LDPE), reinforced PVC, threaded (1/2" BSP)

Electrical characteristics

- **Universal power supply:** 95 V to 240 V
- **Frequency:** 50 Hz to 60 Hz
- **Maximum current:** 1.4 A

Technical performance

- **4 flow rate/pressure ranges:**
 - > Maximum flow rate: 7.6 l/h
 - > Maximum pressure: 17.3 bar
- **Accuracy of set flow rate:** ± 2%
- **Display of the calculated flow rate** for easy adjustment and commissioning
- **Selection of units:** l/h or GPH
- **Backlit screen** for the AD9 series
- **Suction lift:** maximum 1.5 m
- **Maximum temperature of pumped fluids:** + 45 °C
- **Maximum ambient temperature:** + 45 °C
- **Protective cover**
- **Protection:** IP65 (external control connectors IP68)
- **Linear stroke frequency adjustment:** from 1 to 59 strokes/h and from 1 to 120 strokes/min
- **Linear stroke length adjustment:** from 20% to 100% recommended. With AutoPrime™ liquid end: from 50% to 100% recommended
- **On/off switch**
- **Pushbutton:** Increase/Decrease speed
- **Pushbutton:** Internal mode/External mode with 2-colour (yellow/green) LED operating indicator
- **LED operating indicator:** on, fault and alarm indication

Performance

MODEL	MAX. FLOW RATE	MAX. PRESSURE	DIAPHRAGM SIZE	STROKE CAPACITY (ml)		FREQUENCY (spm)		MIN. STROKE LENGTH	MIN. FLOW RATE	CONNECTIONS				
										Plastic liquid ends			S.S. liquid ends	High viscosity liquid ends
										LDPE inch	LDPE metric	Reinforced PVC		
With FastPrime™ liquid end														
AD81*	0.8	17.3	0.2	0.02	0.11	0.02	120	20	160	0.250"OD	3x6mm	6x12mm	1/4" NPTm	0.500"OD
AD84*	1.9	17.3	0.4	0.05	0.26	0.02	120	20	380	0.250"OD	3x6mm	6x12mm	1/4" NPTm	0.500"OD
AD85*	3.8	7.6	0.8	0.11	0.53	0.02	120	20	760	0.375"OD	6x8mm	6x12mm	1/4" NPTm	0.500"OD
AD86*	7.6	3.4	1.6	0.21	1.06	0.02	120	20	1520	0.375"OD	6x8mm	6x12mm	1/4" NPTm	0.500"OD
AD91*	0.8	17.3	0.2	0.02	0.11	0.02	120	20	160	0.250"OD	3x6mm	6x12mm	1/4" NPTm	0.500"OD
AD94*	1.9	17.3	0.4	0.05	0.26	0.02	120	20	380	0.250"OD	3x6mm	6x12mm	1/4" NPTm	0.500"OD
AD95*	3.8	7.6	0.8	0.11	0.53	0.02	120	20	760	0.375"OD	6x8mm	6x12mm	1/4" NPTm	0.500"OD
AD96*	7.6	4.3	1.6	0.21	1.06	0.02	120	20	1520	0.375"OD	6x8mm	6x12mm	1/4" NPTm	0.500"OD
With AutoPrime™ liquid end (for degassing products)														
AD81*	0.6	10.3	0.2	0.02	0.08	0.02	120	50	120	0.250"OD	3x6mm	6x12mm	1/4" NPTm	NOT APPLICABLE
AD84*	1.2	10.3	0.4	0.03	0.17	0.02	120	50	240	0.250"OD	3x6mm	6x12mm	1/4" NPTm	
AD85*	3	7.6	0.8	0.08	0.42	0.02	120	50	600	0.375"OD	6x8mm	6x12mm	1/4" NPTm	
AD86*	6.8	3.4	1.6	0.19	0.94	0.02	120	50	1360	0.375"OD	6x8mm	6x12mm	1/4" NPTm	
AD91*	0.6	10.3	0.2	0.02	0.08	0.02	120	50	120	0.250"OD	3x6mm	6x12mm	1/4" NPTm	
AD94*	1.2	10.3	0.4	0.03	0.17	0.02	120	50	240	0.250"OD	3x6mm	6x12mm	1/4" NPTm	
AD95*	3	7.6	0.8	0.08	0.42	0.02	120	50	600	0.375"OD	6x8mm	6x12mm	1/4" NPTm	
AD96*	6.8	3.4	1.6	0.19	0.94	0.02	120	50	1360	0.375"OD	6x8mm	6x12mm	1/4" NPTm	

* When ordering, please specify the voltage code by using one of the following numbers: **3** = 95-240 V, DIN plug / **5** = 95-240 V, UK plug / **8** = 95-240 V, without plug

Control modes

- **Manual control** by linear adjustment of the stroke frequency and stroke length
- **External pulse control** by volt-free contact with **integrated control pulse division/multiplication** (from 1 to 999).
The stroke frequency is then set by external pulses, for example from a water meter
- **Direct external proportional control by 4-20 mA** analogue signal (direct or indirect response).
The amount of product injected is proportional to the intensity of the input signal in mA
- **Power supply output** (24 VDC) for connection of accessories such as a flow monitor
- **Remote on/off**
- Possibility of connecting a **level switch** (optional accessory) to monitor the product transfer operation
- Possibility of connecting a **Digi-Pulse™ flow monitor** to monitor the flow rate automatically and trigger an alarm if there is a fault

AD9 series only

The AD9 series can supply the following information as an output via a 6-pin connector:

- **Pulses:** the pump will supply a 100 ms pulse each stroke
- **4-20 mA analogue signal**
- **Remote alarm transfer**
- **Remote control of the switch between internal and external mode**
- **Closing of the alarm contact**

AD9 series advanced configuration menu

- **7-day event timer:** pre-programmed triggering of injection at the correct time with no intervention of any external device
- **Batch accumulation dosing:** if the pulse multiplication setting is selected, this option is used to accumulate the dosing of the batches.
A batch is dosed each time the pump receives an external pulse. If the pump receives new pulses before a batch is complete, this setting makes it possible to take account of these pulses and deliver the dosed amount of product. If this option is inactive, the pulses are ignored
- **Pulse width:** programming of the pulse width (from 4 ms to 60 ms, in 4 ms increments) so that it is exactly right for the process
- **Percent-of-time operation:** programming of injection cycles (for example, the pump will inject for 2 minutes and will then be stopped for 8 minutes)
- **Pump calibration:** quick, simple calibration of the pump to adapt it to the actual conditions of use
- **Remote alarm transfer**
- **Alarm:** stops the pump according to the alarm mode selected
- **Closing of the alarm contact:** remote stopping of the pump by an external contact signal, without having to switch off the electricity supply to the pump
- **Locking:** protection of the pump's settings, avoiding incorrect operation. The pump can be locked using a 4-digit code
- **Remote control of the switch between internal and external mode**
- **Return to default factory settings**

Accessories

Excel™ AD pumps are delivered ready to use. For standard liquid ends, apart from the stainless steel version, the following accessories are supplied with the pump: an injection nozzle, a foot valve, a ceramic weight, connection and bleed tubing, and the external control cable(s) (depending on the model).

A **4-function valve** is an ideal addition for your installation. The **anti-siphon** function enables downstream dosing or dosing in a low pressure line; the **back pressure valve** function maintains a counter-pressure of 1.4 bar on the dosing pump to prevent excess flow due to lack of discharge line pressure; the **priming** function enables the pump to be primed even if it connected to a pressurised line; the **line depressurisation** function makes it easier to carry out maintenance operations by depressurising the discharge line without having to loosen or disconnect the tubing.

Milton Roy Europe proposes a wide range of accessories to complete the installation of your pump.



Spare parts

Milton Roy Europe advises you on the essential wear parts to be kept on hand in order to optimize the performance of your equipment.



Dosing stations

A turnkey solution
Compact and fully-featured, DOSAPACK® stations are ideal for the preparation, storage and injection of reagent solutions.



Coding | Standard & options

PLASTIC LIQUID ENDS

Excel™ AD											
AD Electromagnetic dosing pump Excel™ AD											
Control											
8	Series AD8 - Pulse control / 4-20 mA / Dual manual control / Flow rate display (calculated)										
9	Series AD9 - Programmable / Pulse control / 4-20 mA / Dual manual control / Flow rate display (calculated)										
Output (max. Flow rate / Pressure)											
	FastPrime™ liquid end			AutoPrime™ liquid end			AutoPrime™ liquid end recommended for products which require automatic and continuous degassing				
	l/h	bar		l/h	bar						
1	0.8	17.3		0.6	10.3						
4	1.9	17.3		1.2	10.3						
5	3.8	7.6		3	7.6						
6	7.6	3.4		6.8	3.4						
Power supply											
3	95-240 V, DIN plug										
5	95-240 V, UK plug										
8	95-240 V, without plug										
Liquid end material											
	/	ADx1	ADx4	ADx5	ADx6	Head	Fittings	Cartridges	Seats	Seals	Balls
FastPrime™ liquid end											
812	x					PVDF	PVDF	PVDF	PTFE	Aflas®	Ceramic
813	x					PVDF	PVDF	PVDF	PTFE	PTFE	Ceramic
818	x					PVC	PVC	PVDF	PTFE	Aflas®	Ceramic
910	x					Acrylic	PVC	PVDF	PTFE	Aflas®	Ceramic
915	x					PP	PP	PVDF	PTFE	PTFE	Ceramic
919	x					Acrylic	PVDF	PVDF	PTFE	Aflas®	PTFE
822		x				PVDF	PVDF	PVDF	Aflas®	Aflas®	Ceramic
823		x				PVDF	PVDF	PVDF	PTFE	PTFE	Ceramic
828		x				PVC	PVC	PVDF	Aflas®	Aflas®	Ceramic
920		x				Acrylic	PVC	PVDF	Aflas®	Aflas®	Ceramic
925		x				PP	PP	PVDF	PTFE	PTFE	Ceramic
929		x				Acrylic	PVDF	PVDF	Aflas®	Aflas®	PTFE
832			x			PVDF	PVDF	PVDF	Aflas®	Aflas®	Ceramic
833			x			PVDF	PVDF	PVDF	PTFE	PTFE	Ceramic
838			x			PVC	PVC	PVDF	Aflas®	Aflas®	Ceramic
930			x			Acrylic	PVC	PVDF	Aflas®	Aflas®	Ceramic
935			x			PP	PP	PVDF	PTFE	PTFE	Ceramic
939			x			Acrylic	PVDF	PVDF	Aflas®	Aflas®	PTFE
842				x		PVDF	PVDF	PVDF	Aflas®	Aflas®	Ceramic
843				x		PVDF	PVDF	PVDF	PTFE	PTFE	Ceramic
848				x		PVC	PVC	PVDF	Aflas®	Aflas®	Ceramic
940				x		Acrylic	PVC	PVDF	Aflas®	Aflas®	Ceramic
945				x		PP	PP	PVDF	PTFE	PTFE	Ceramic
949				x		Acrylic	PVDF	PVDF	Aflas®	Aflas®	PTFE
AutoPrime™ liquid end for degassing products											
910	x					Acrylic	PVC	PVDF	PTFE	Aflas®	Ceramic
920		x				Acrylic	PVC	PVDF	Aflas®	Aflas®	Ceramic
930			x			Acrylic	PVC	PVDF	Aflas®	Aflas®	Ceramic
940				x		Acrylic	PVC	PVDF	Aflas®	Aflas®	Ceramic
Head / Valve											
N	For FastPrime™ liquid end only - Standard FastPrime™ liquid end										
S	For FastPrime™ liquid end only - FastPrime™ liquid end + 4-function valve (anti-siphoning, back pressure, priming, depressurization)										
A	For AutoPrime™ liquid end only - Standard AutoPrime™ liquid end										
H	For AutoPrime™ liquid end only - AutoPrime™ liquid end + 4-function valve (anti-siphoning, back pressure, priming, depressurization)										
Connections											
0	For FastPrime™ liquid end only - Pipe thread (1/2" BSP). Non available on acrylic liquid ends										
2	For FastPrime™ and AutoPrime™ liquid ends only - Inch tubing connections										
3	For FastPrime™ and AutoPrime™ liquid ends only - Metric tubing connections										
4	For FastPrime™ liquid end N code and AutoPrime™ liquid end A code only - Reinforced PVC tubing (6x12 mm). Non available on liquid end with 4-functions valve (B or S code)										
AD	9	4	3	-	828	N	3				

STAINLESS STEEL LIQUID ENDS

Excel™ AD											
AD	Electromagnetic dosing pump Excel™ AD										
Control											
8	Series AD8 - Pulse control / 4-20 mA / Dual manual control / Flow rate display (calculated)										
9	Series AD9 - Programmable / Pulse control / 4-20 mA / Dual manual control / Flow rate display (calculated)										
Output (max. Flow rate / Pressure)											
/	FastPrime™ liquid end										
	l/h	bar									
1	0.8	17.3									
4	1.9	17.3									
5	3.8	7.6									
6	7.6	3.4									
Power supply											
3	95-240 V, DIN plug										
5	95-240 V, UK plug										
8	95-240 V, without plug										
-											
Liquid end material											
/	ADx1	ADx4	ADx5	ADx6	Head	Fittings	Cartridges	Seats	Seals	Balls	
Stainless steel liquid end											
917	×				316	316	-	316	PTFE	316	
927		×			316	316	-	316	PTFE	316	
937			×		316	316	-	316	PTFE	316	
947				×	316	316	-	316	PTFE	316	
AD	9	4	3	-	927						

HIGH VISCOSITY LIQUID ENDS

Excel™ AD												
AD	Electromagnetic dosing pump Excel™ AD											
Control												
8	Series AD8 - Pulse control / 4-20 mA / Dual manual control / Flow rate display (calculated)											
9	Series AD9 - Programmable / Pulse control / 4-20 mA / Dual manual control / Flow rate display (calculated)											
Output (max. Flow rate / Pressure)												
/	FastPrime™ liquid end											
	l/h	bar										
4	1.9	17.3										
5	3.8	7.6										
6	7.6	3.4										
Power supply												
3	95-240 V, DIN plug											
5	95-240 V, UK plug											
8	95-240 V, without plug											
-												
Liquid end material												
/	ADx1	ADx4	ADx5	ADx6	Head	Fittings	Cartridges	Seats	Seals	Balls		
High viscosity liquid ends												
624		×			PP	PP	-	PTFE	PTFE	316		
626		×			Acrylic	PP	-	Viton®	Aflas®	316		
634			×		PP	PP	-	PTFE	PTFE	316		
636			×		Acrylic	PP	-	Viton®	Aflas®	316		
644				×	PP	PP	-	PTFE	PTFE	316		
646				×	Acrylic	PP	-	Viton®	Aflas®	316		
Head / Valve												
V	High viscosity liquid end											
AD	9	4	3	-	624	V						

Dimensions and packing

Dimensions (in mm)

Mounting information

View A

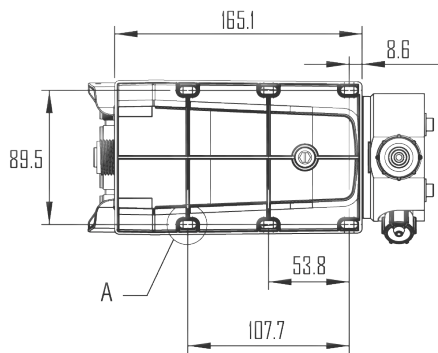
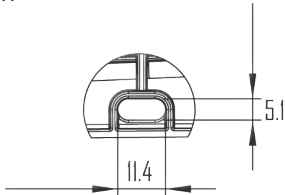

FastPrime™ LIQUID ENDS

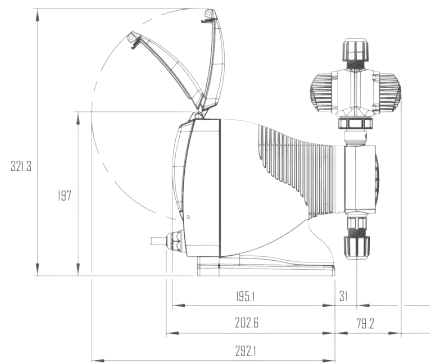
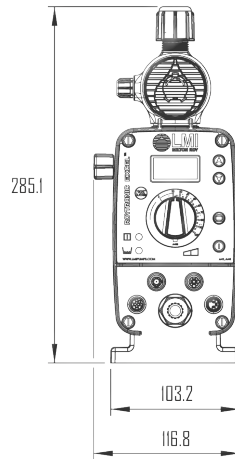

AutoPrime™ LIQUID ENDS

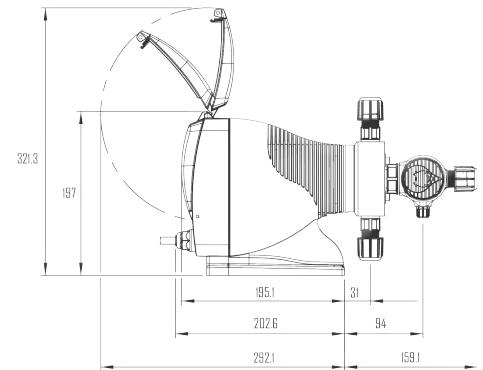
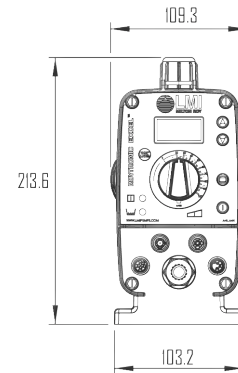

MAXIMUM GROSS WEIGHT (*) kg	PACKING (mm) (L x W x H)
4.75	328 x 238 x 287

(*) Approximately

The overall dimensions are provided as an indication only.

They correspond to the maximum dimensions and vary according to the liquid end selected.