

# DT KNIFE GATE VALVE

The DT model knife gate valve is a bi-directional wafer type double gate valve that is widely used in the Pulp and Paper industry (paper recycling). This valve has been specially designed to handle high concentrated or contaminated media

## Product description:

- Bi-directional wafer type double gate knife gate valve
- Size range of DN100-600 (larger sizes upon request). See Dimension Charts for pressure rating
- Standard flange connection: EN 1092 PN10 and ASME B16.5 (class 150)  
Others available upon request
- Double acting pneumatic actuation
- For EU Directives and other Certificates, please see the document:  
Directives and Certificates Compliance - Knife Gate Valves - Catalogues and Datasheets

## Features:

- Internally machined cast or fabricated two-part bolted body with HMWPE liners for optimum gate guiding and sliding when traveling
- Full port design for greater flow capacity and minimal pressure drop
- Dual stainless steel gate, polished both sides to avoid jamming and seat damage
- Two cast stainless steel seat rings, easily replaceable, that protect the body
- Double packing with easy access and adjustable packing glands ensuring a tight seal. Long life PTFE impregnated synthetic fiber plus EPDM O-ring. Wide range of packing materials available
- RAL-5015 blue epoxy-coating on all cast iron/carbon steel components
- Automated valves provided with gate guards in accordance with EU Safety Standards
- Other options: special materials, fabricated valves, etc.
- Actuation accessories: limit & proximity switches, mechanical stops, positioners, solenoid valves, manual overrides, locking devices and fail safe systems

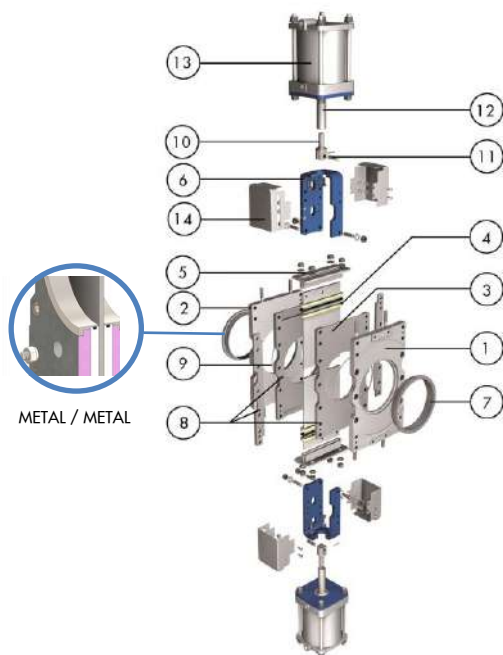

## STANDARD PARTS LIST

Part	Carbon Steel / Stainless steel
1 Body	Carbon steel / AISI 316
2 Body	Carbon steel / AISI 316
3 Gate	AISI 304 / AISI 316
4 Packing	PTFE impreg. synth. fibre + EPDM O-ring
5 Gland Follower	Carbon steel / AISI 316
6 Yoke	Carbon steel - Epoxy coated
7 Seat Rings	CF8M
8 Body Liner	HMW Polyethylene
9 O-ring	Nitrile
10 Clevis	17-4 PH
11 Pin	AISI 304 (1.4301)
12 Piston Rod	AISI 304 (1.4301)
13 Cylinder	Aluminium
14 Gate Guards	AISI 304 (1.4301)

# DT

## KNIFE GATE VALVE

### DIMENSIONS (mm) Pneumatic Actuator (D/A)

DN	Pressures	A	B	C	D	E	F	G	H	Weight (kg.)	Std.Cyl.	Connect.
100	10 bar	50	162	100	140	132	169	115	882	48	C100/52	1/4"G
125	10 bar	50	210	100	146	142	179	140	934	56	C125/65	1/4"G
150	10 bar	60	215	100	175	154	206	140	1070	67	C125/78	1/4"G
200	10 bar	60	265	165	210	204	241	175	1310	80	C160/103	1/4"G
250	10 bar	70	330	270	265	231	285	220	1562	90	C200/128	3/8"G
300	6 bar	70	380	270	300	256	310	220	1732	160	C200/153	3/8"G
350	6 bar	96	450	270	325	325	340	277	1980	255	C250/180	3/8"G
400	6 bar	100	510	270	350	355	365	277	2140	340	C250/205	3/8"G
450	5 bar	106	565	270	405	379	401	382	2370	405	C300/230	1/2"G
500	4 bar	114	610	270	450	420	445	382	2630	490	C300/255	1/2"G
600	4 bar	114	715	270	500	470	495	382	2930	580	C300/305	1/2"G

