

# CHECK VALVE

Cast Steel Swing Check Valve  
PN16-F6, DN40~DN600

**MODEL: KRD-SCF**

## » Features

- Suitable for a wide range of industry and media
- Precision, high quality castings
- Suitable for both horizontal and vertical installation
- Bolted cover; robust construction
- EN10204-3.1 Material certificate available

## » Standards

- Basic design to DIN 3840
- Face-to-face acc. to DIN 3202-F6
- End flange dimension acc. to EN 1092-1
- Inspection & test acc. to API 598 or EN 12266-1

## » Temperature Range

Metal seat : -10°C to 450°C

## » Limitation

- If installed in a vertical position, the direction of flow must be in an up-flow direction
- If installed in a horizontal position, the valve must be installed with the cover oriented to the top

## Materials List:

NO	PART NAME	MATERIAL
1	BODY	DIN 17245 GS-C25 + 13Cr
2	DISC	DIN 17245 GS-C25 + 13Cr
3	DISC NUT	ASTM A194 2H
4	DISC WASHER	AISI 1025
5	HINGE	DIN 17245 GS-C25
6	HINGE PIN	ASTM A276 410
7	BONNET GASKET	SS304+FLEXIBLE GRAPHITE
8	BONNET	DIN 17245 GS-C25
9	BONNET NUT	ASTM A194 2H
10	BONNET BOLT	ASTM A193 B7
11	HOOK SCREW	CARBON STEEL
12	GASKET	COOPER ALLOY
13	DRAIN PLUG	CARBON STEEL

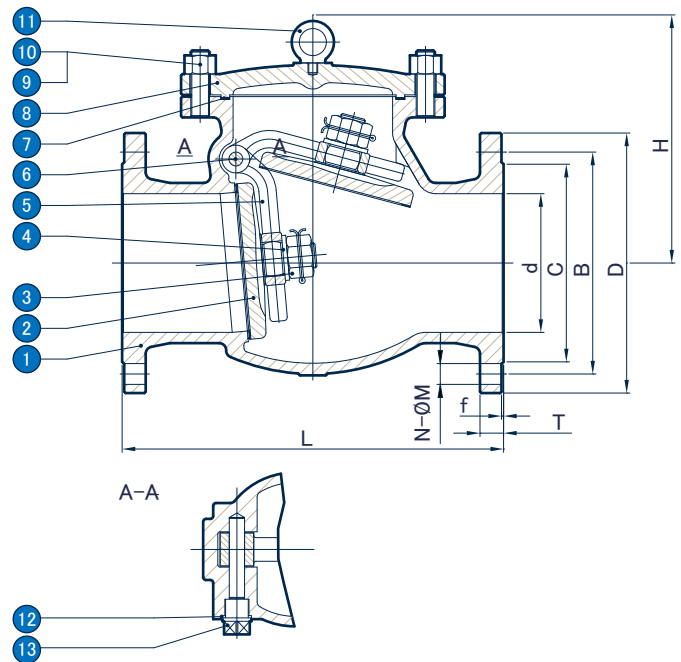

## Dimensions (mm):

SIZE		d	D	B	C	L	H	T	f	N	M	Weight kg
IN	DN											
1½"	40	40	150	110	88	180	140	18	3	4	18	-
2"	50	50	165	125	102	200	150	18	3	4	18	17
2½"	65	65	185	145	122	240	168	18	3	4	18	22
3"	80	80	200	160	138	260	180	20	3	8	18	30.5
4"	100	100	220	180	158	300	210	20	3	8	18	38
5"	125	125	250	210	188	350	230	22	3	8	18	53
6"	150	150	285	240	212	400	275	22	3	8	22	75.5
8"	200	200	340	295	268	500	340	24	3	12	22	119
10"	250	250	405	355	320	600	355	26	3	12	26	205
12"	300	300	460	410	378	700	410	28	4	12	26	262
14"	350	350	520	470	438	800	475	30	4	16	26	440
16"	400	400	580	525	490	900	552	32	4	16	30	550
20"	500	500	715	650	610	1100	660	36	4	20	33	-
24"	600	600	840	770	725	1300	740	40	5	20	36	-

Note: Torque measured at ambient temperature with no loading ; safety factor is not included.

KLINGER Portugal, Ltd.

Tel +351 229 470 910 | www.klinger.pt | geral@klinger.pt

# CHECK VALVE

Cast Steel Swing Check Valve  
PN25-F6, DN40~DN600

**MODEL: KRD-SCF**

## » Features

- Suitable for a wide range of industry and media
- Precision, high quality castings
- Suitable for both horizontal and vertical installation
- Bolted cover; robust construction
- EN10204-3.1 Material certificate available

## » Standards

- Basic design to DIN 3840
- Face-to-face acc. to DIN 3202-F6
- End flange dimension acc. to EN 1092-1
- Inspection & test acc. to API 598 or EN 12266-1

## » Temperature Range

Metal seat : -10°C to 450°C

## » Limitation

- If installed in a vertical position, the direction of flow must be in an up-flow direction
- If installed in a horizontal position, the valve must be installed with the cover oriented to the top

## Materials List:

NO	PART NAME	MATERIAL
1	BODY	DIN 17245 GS-C25 + 13Cr
2	DISC	DIN 17245 GS-C25 + 13Cr
3	DISC NUT	ASTM A194 2H
4	DISC WASHER	AISI 1025
5	HINGE	DIN 17245 GS-C25
6	HINGE PIN	ASTM A276 410
7	BONNET GASKET	SS304+FLEXIBLE GRAPHITE
8	BONNET	DIN 17245 GS-C25
9	BONNET NUT	ASTM A194 2H
10	BONNET BOLT	ASTM A193 B7
11	HOOK SCREW	CARBON STEEL
12	GASKET	COOPER ALLOY
13	DRAIN PLUG	CARBON STEEL

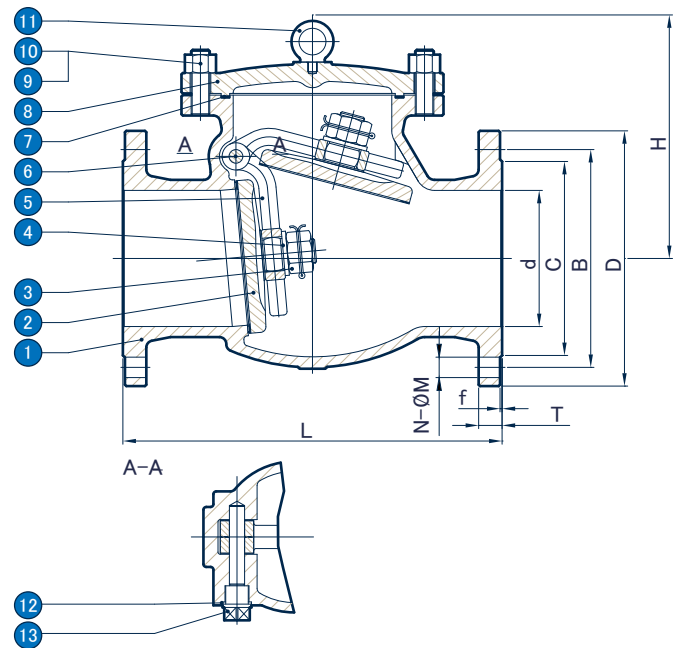

## Dimensions (mm):

SIZE		d	D	B	C	L	H	T	f	N	M
IN	DN										
1½"	40	40	150	110	88	180	140	18	3	4	18
2"	50	50	165	125	102	200	150	20	3	4	18
2½"	65	65	185	145	122	240	168	22	3	8	18
3"	80	80	200	160	138	260	180	24	3	8	18
4"	100	100	235	190	162	300	210	24	3	8	22
5"	125	125	270	220	188	350	230	26	3	8	26
6"	150	150	300	250	218	400	275	28	3	8	26
8"	200	200	360	310	278	500	340	30	3	12	26
10"	250	250	425	370	335	600	355	32	3	12	30
12"	300	300	485	430	395	700	410	34	4	16	30
14"	350	350	555	490	450	800	475	38	4	16	33
16"	400	400	620	550	505	900	552	40	4	16	36
20"	500	500	730	660	615	1100	660	44	4	20	36
24"	600	600	845	770	720	1300	740	46	5	20	39

# CHECK VALVE

Cast Steel Swing Check Valve  
PN40-F1, DN40~DN600

**MODEL: KRD-SCF**

## » Features

- Suitable for a wide range of industry and media
- Precision, high quality castings
- Suitable for both horizontal and vertical installation
- Bolted cover; robust construction
- EN10204-3.1 Material certificate available

## » Standards

- Basic design to DIN 3840
- Face-to-face acc. to DIN 3202-F6
- End flange dimension acc. to EN 1092-1
- Inspection & test acc. to API 598 or EN 12266-1

## » Temperature Range

Metal seat : -10°C to 450°C

## » Limitation

- If installed in a vertical position, the direction of flow must be in an up-flow direction
- If installed in a horizontal position, the valve must be installed with the cover oriented to the top

## Materials List:

NO	PART NAME	MATERIAL
1	BODY	DIN 17245 GS-C25 + 13Cr
2	DISC	DIN 17245 GS-C25 + 13Cr
3	DISC NUT	ASTM A194 2H
4	DISC WASHER	AISI 1025
5	HINGE	DIN 17245 GS-C25
6	HINGE PIN	ASTM A276 410
7	BONNET GASKET	SS304+FLEXIBLE GRAPHITE
8	BONNET	DIN 17245 GS-C25
9	BONNET NUT	ASTM A194 2H
10	BONNET BOLT	ASTM A193 B7
11	HOOK SCREW	CARBON STEEL
12	GASKET	COOPER ALLOY
13	DRAIN PLUG	CARBON STEEL

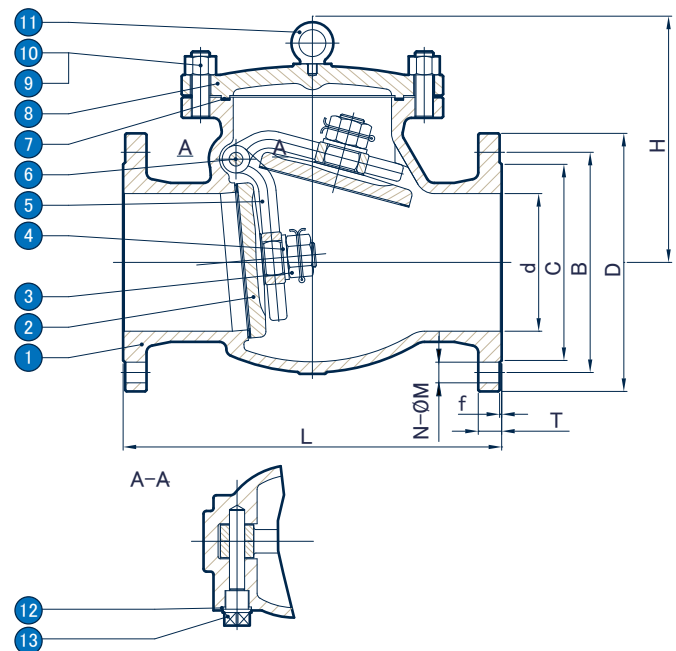

## Dimensions (mm):

SIZE		d	D	B	C	L	H	T	f	N	M
IN	DN										
1½"	40	40	150	110	88	200	140	18	3	4	18
2"	50	50	165	125	102	230	155	20	3	4	18
2½"	65	65	185	145	122	290	172	22	3	8	18
3"	80	80	200	160	138	310	185	24	3	8	18
4"	100	100	235	190	162	350	215	24	3	8	22
5"	125	125	270	220	188	400	235	26	3	8	26
6"	150	150	300	250	218	480	285	28	3	8	26
8"	200	200	375	320	285	600	350	34	3	12	30
10"	250	250	450	385	345	730	360	38	3	12	33
12"	300	300	515	450	410	850	425	42	4	16	33
14"	350	350	580	510	465	980	490	46	4	16	36
16"	400	400	660	585	535	1100	565	50	4	16	39
20"	500	500	755	670	615	1250	680	52	4	20	42
24"	600	600	890	795	735	1450	760	60	5	20	48

# CHECK VALVE

Cast Steel Swing Check Valve  
PN63-F2, DN40~DN500

**MODEL: KRD-SCF**

## » Features

- Suitable for a wide range of industry and media
- Precision, high quality castings
- Suitable for both horizontal and vertical installation
- Bolted cover; robust construction
- EN10204-3.1 Material certificate available

## » Standards

- Basic design to DIN 3840
- Face-to-face acc. to DIN 3202-F6
- End flange dimension acc. to EN 1092-1
- Inspection & test acc. to API 598 or EN 12266-1

## » Temperature Range

Metal seat : -10°C to 450°C

## » Limitation

- If installed in a vertical position, the direction of flow must be in an up-flow direction
- If installed in a horizontal position, the valve must be installed with the cover oriented to the top

## Materials List:

NO	PART NAME	MATERIAL
1	BODY	DIN 17245 GS-C25 + 13Cr
2	DISC	DIN 17245 GS-C25 + 13Cr
3	DISC NUT	ASTM A194 2H
4	DISC WASHER	AISI 1025
5	HINGE	DIN 17245 GS-C25
6	HINGE PIN	ASTM A276 410
7	BONNET GASKET	SS304+FLEXIBLE GRAPHITE
8	BONNET	DIN 17245 GS-C25
9	BONNET NUT	ASTM A194 2H
10	BONNET BOLT	ASTM A193 B7
11	HOOK SCREW	CARBON STEEL
12	GASKET	COOPER ALLOY
13	DRAIN PLUG	CARBON STEEL

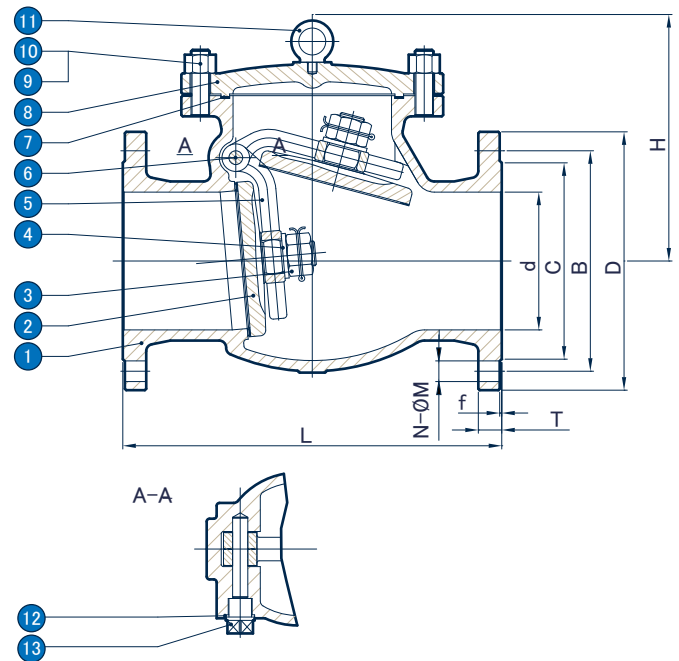

## Dimensions (mm):

SIZE		d	D	B	C	L	H	T	f	N	M
IN	DN										
1½"	40	40	170	125	88	260	140	26	3	4	22
2"	50	50	180	135	102	300	155	26	3	4	22
2½"	65	65	205	160	122	340	172	26	3	8	22
3"	80	80	215	170	138	380	185	28	3	8	22
4"	100	100	250	200	162	430	215	30	3	8	28
5"	125	125	295	240	188	500	235	34	3	8	30
6"	150	150	345	280	218	550	285	36	3	8	33
8"	200	200	415	345	285	650	350	42	3	12	36
10"	250	250	470	400	345	775	360	48	3	12	36
12"	300	300	530	460	410	900	425	52	4	16	36
14"	350	350	600	525	465	1025	490	56	4	16	39
16"	400	400	670	585	535	1150	565	60	4	16	42
20"	500	500	800	705	615	1400	680	68	4	20	48

# CHECK VALVE

Cast Steel Swing Check Valve  
CLASS 150, 2"~4"

**MODEL: KRD-SCF**

## » Features

- Suitable for a wide range of industry and media
- Precision, high quality castings
- Suitable for both horizontal and vertical installation
- Bolted cover; robust construction
- EN10204-3.1 Material certificate available

## » Standards

- Basic design to API6D
- Face-to-face acc. to B16.10
- End flange dimension acc. to B16.5
- Inspection & test acc. to API 598

## » Temperature Range

Metal seat : -29°C to 450°C

## » Limitation

- If installed in a vertical position, the direction of flow must be in an up-flow direction
- If installed in a horizontal position, the valve must be installed with the cover oriented to the top

## Materials List:

NO	PART NAME	MATERIAL
1	BODY	ASTM A216 WCB
2	SEAT RING	ASTM A105+13Cr
3	DISC	ASTM A216 WCB+13Cr
4	HINGE	ASTM A216 WCB
5	DISC WASHER	AISI 1025
6	DISC NUT	ASTM A194 2H
7	HINGE PIN	ASTM A276 410
8	GASKET	SS304+Flexible Graphite
9	COVER	ASTM A216 WCB
10	NUT	ASTM A194 2H
11	BOLT	ASTM A193 B7
12	GASKET	COPPER ALLOYS
13	DRAIN PLUG	CARBON STEEL

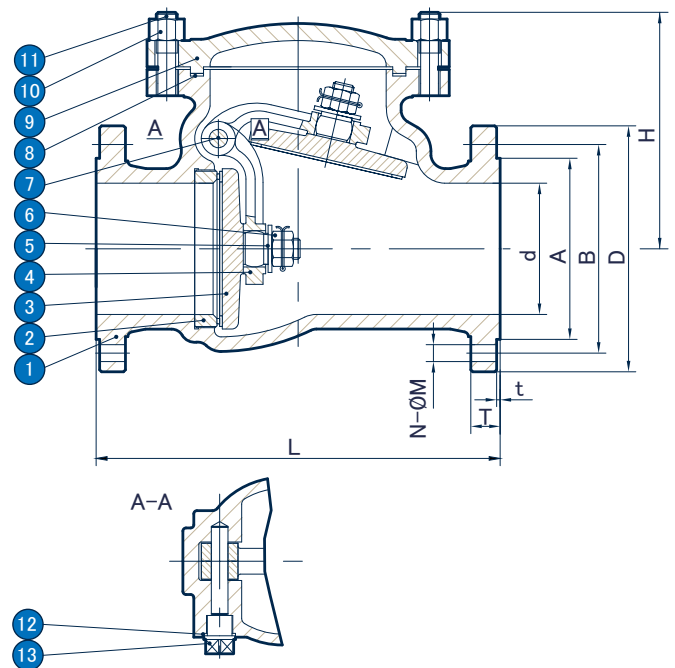

## Dimensions (mm):

SIZE		d	L	H	T	t	A	B	D	N-ØM	Weight kg
IN	DN										
2"	50	49	203	133	16	1.6	92	120.5	152	4-Ø19	14
2½"	65	62	216	148	18	1.6	105	139.5	178	4-Ø19	20
3"	80	74	241	160	19	1.6	127	152.5	190	4-Ø19	25
4"	100	100	295	187	24	1.6	157	190.5	229	8-Ø19	42

Note: Torque measured at ambient temperature with no loading ; safety factor is not included.

# CHECK VALVE

Cast Steel Swing Check Valve  
CLASS 150, 6"~24"

MODEL: KRD-SCF

## » Features

- Suitable for a wide range of industry and media
- Precision, high quality castings
- Suitable for both horizontal and vertical installation
- Bolted cover; robust construction
- EN10204-3.1 Material certificate available

## » Standards

- Basic design to API6D
- Face-to-face acc. to B16.10
- End flange dimension acc. to B16.5
- Inspection & test acc. to API 598

## » Temperature Range

Metal seat : -29°C to 450°C

## » Limitation

- If installed in a vertical position, the direction of flow must be in an up-flow direction
- If installed in a horizontal position, the valve must be installed with the cover oriented to the top

## Materials List:

NO	PART NAME	MATERIAL
1	BODY	ASTM A216 WCB
2	SEAT RING	ASTM A105+13Cr
3	DISC	ASTM A216 WCB+13Cr
4	HINGE	ASTM A216 WCB
5	DISC WASHER	AISI 1025
6	DISC NUT	ASTM A194 2H
7	HINGE PIN	ASTM A276 410
8	GASKET	SS304+Flexible Graphite
9	COVER	ASTM A216 WCB
10	NUT	ASTM A194 2H
11	BOLT	ASTM A193 B7
11	GASKET	COPPER ALLOYS
12	DRAIN PLUG	CARBON STEEL

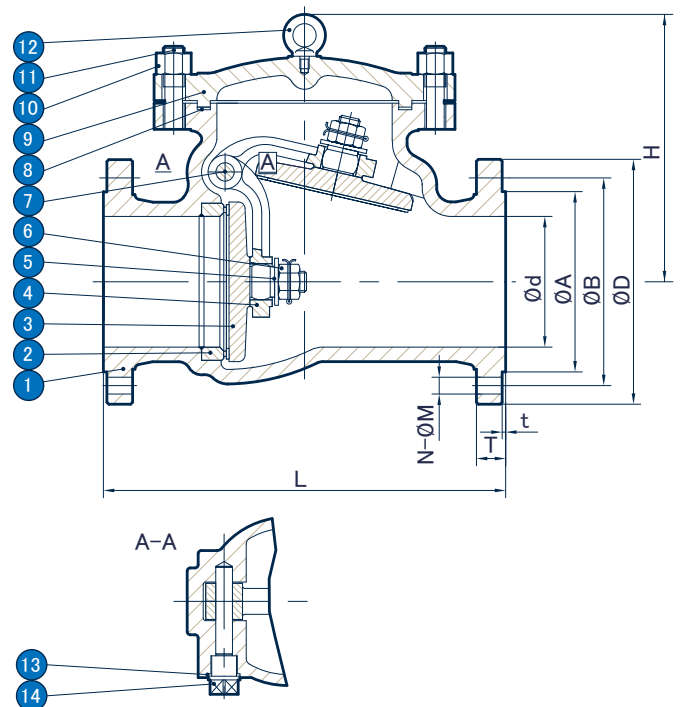

## Dimensions (mm):

SIZE		d	L	H	T	t	A	B	D	N-ØM	Weight kg
IN	DN										
6"	150	150	356	275	26	1.6	216	241.5	279	8-Ø22	66
8"	200	201	495	340	29	1.6	270	298.5	343	8-Ø22	126
10"	250	252	622	355	31	1.6	324	362	406	12-Ø25	195
12"	300	303	698	410	32	1.6	381	432	483	12-Ø25	300
14"	350	334	787	475	35	1.6	413	476	533	12-Ø29	440
16"	400	385	864	552	37	1.6	470	540	597	16-Ø29	550
18"	450	436	978	600	40	1.6	533	578	635	16-Ø32	720
20"	500	487	978	660	43	1.6	584	635	699	20-Ø32	-
24"	600	589	1295	740	48	1.6	692	749.5	813	20-Ø35	-

Note: Torque measured at ambient temperature with no loading ; safety factor is not included.

# CHECK VALVE

Cast Steel Swing Check Valve  
CLASS 300, 2"~4"

**MODEL: KRD-SCF**

## » Features

- Suitable for a wide range of industry and media
- Precision, high quality castings
- Suitable for both horizontal and vertical installation
- Bolted cover; robust construction
- EN10204-3.1 Material certificate available

## » Standards

- Basic design to API6D
- Face-to-face acc. to B16.10
- End flange dimension acc. to B16.5
- Inspection & test acc. to API 598

## » Temperature Range

Metal seat : -29°C to 450°C

## » Limitation

- If installed in a vertical position, the direction of flow must be in an up-flow direction
- If installed in a horizontal position, the valve must be installed with the cover oriented to the top

## Materials List:

NO	PART NAME	MATERIAL
1	BODY	ASTM A216 WCB
2	SEAT RING	ASTM A105+13Cr
3	DISC	ASTM A216 WCB+13Cr
4	HINGE	ASTM A216 WCB
5	DISC WASHER	AISI 1025
6	DISC NUT	ASTM A194 2H
7	HINGE PIN	ASTM A276 410
8	GASKET	SS304+Flexible Graphite
9	COVER	ASTM A216 WCB
10	NUT	ASTM A194 2H
11	BOLT	ASTM A193 B7
12	GASKET	COPPER ALLOYS
13	DRAIN PLUG	CARBON STEEL

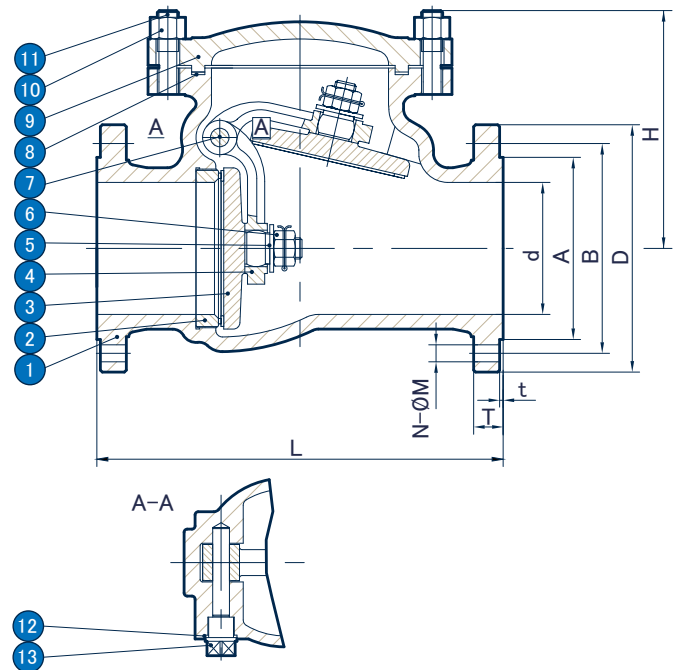

## Dimensions (mm):

SIZE		d	L	H	T	t	A	B	D	N-ØM	Weight kg
IN	DN										
2"	50	49	267	150	23	1.6	92	127	165	8-Ø19	20
2½"	65	62	292	170	26	1.6	105	149	190	8-Ø22	28.2
3"	80	74	318	190	29	1.6	127	168.5	210	8-Ø22	39
4"	100	100	356	210	32	1.6	157	200	254	8-Ø22	62

Note: Torque measured at ambient temperature with no loading ; safety factor is not included.

# CHECK VALVE

Cast Steel Swing Check Valve  
CLASS 300, 6"~24"

MODEL: KRD-SCF

## » Features

- Suitable for a wide range of industry and media
- Precision, high quality castings
- Suitable for both horizontal and vertical installation
- Bolted cover; robust construction
- EN10204-3.1 Material certificate available

## » Standards

- Basic design to API6D
- Face-to-face acc. to B16.10
- End flange dimension acc. to B16.5
- Inspection & test acc. to API 598

## » Temperature Range

Metal seat : -29°C to 450°C

## » Limitation

- If installed in a vertical position, the direction of flow must be in an up-flow direction
- If installed in a horizontal position, the valve must be installed with the cover oriented to the top

## Materials List:

NO	PART NAME	MATERIAL
1	BODY	ASTM A216 WCB
2	SEAT RING	ASTM A105+13Cr
3	DISC	ASTM A216 WCB+13Cr
4	HINGE	ASTM A216 WCB
5	DISC WASHER	AISI 1025
6	DISC NUT	ASTM A194 2H
7	HINGE PIN	ASTM A276 410
8	GASKET	SS304+Flexible Graphite
9	COVER	ASTM A216 WCB
10	NUT	ASTM A194 2H
11	BOLT	ASTM A193 B7
12	HOOK SCREW	CARBON STEEL
13	GASKET	COPPER ALLOYS
14	DRAIN PLUG	CARBON STEEL

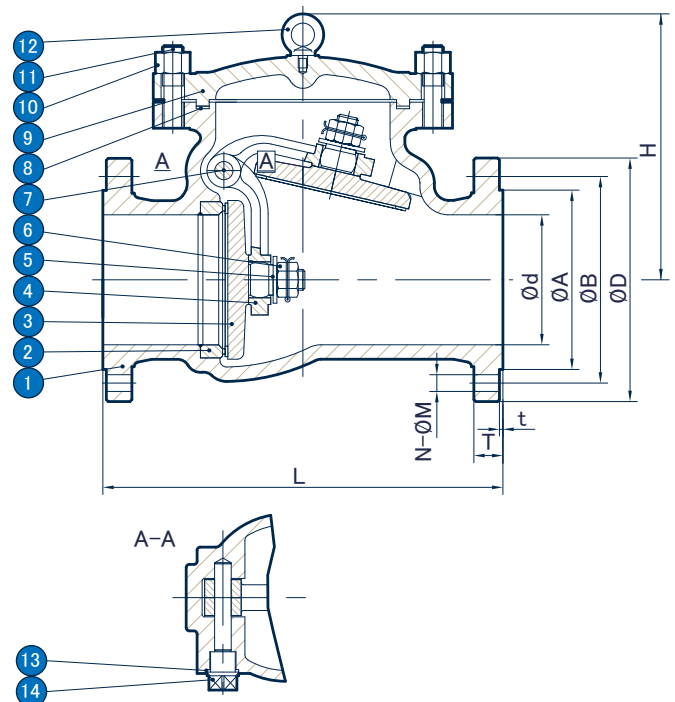

## Dimensions (mm):

SIZE		d	L	H	T	t	A	B	D	N-ØM	Weight kg
IN	DN										
6"	150	150	444	360	37	1.6	216	270	318	12-Ø22	114
8"	200	201	533	370	42	1.6	270	330	381	12-Ø25	198
10"	250	252	622	385	48	1.6	324	387.5	445	16-Ø29	307
12"	300	303	711	440	51	1.6	381	451	521	16-Ø32	480
14"	350	334	838	520	54	1.6	413	514.5	584	20-Ø32	664
16"	400	385	864	554	58	1.6	470	571.5	648	20-Ø35	777
18"	450	436	978	620	61	1.6	533	628.5	711	24-Ø35	1050
20"	500	487	1016	680	64	1.6	584	686	775	24-Ø35	-
24"	600	589	1346	770	70	1.6	692	813	914	24-Ø41	-

Note: Torque measured at ambient temperature with no loading ; safety factor is not included.



# CHECK VALVE

Cast Steel Swing Check Valve  
CLASS 600, 2"~3"

**MODEL: KRD-SCF**

## » Features

- Suitable for a wide range of industry and media
- Precision, high quality castings
- Suitable for both horizontal and vertical installation
- Bolted cover; robust construction
- EN10204-3.1 Material certificate available

## » Standards

- Basic design to API6D
- Face-to-face acc. to B16.10
- End flange dimension acc. to B16.5
- Inspection & test acc. to API 598

## » Temperature Range

Metal seat : -29°C to 450°C

## » Limitation

- If installed in a vertical position, the direction of flow must be in an up-flow direction
- If installed in a horizontal position, the valve must be installed with the cover oriented to the top

## Materials List:

NO	PART NAME	MATERIAL
1	BODY	ASTM A216 WCB
2	SEAT RING	ASTM A105+13Cr
3	DISC	ASTM A216 WCB+13Cr
4	HINGE	ASTM A216 WCB
5	DISC WASHER	AISI 1025
6	DISC NUT	ASTM A194 2H
7	HINGE PIN	ASTM A276 410
8	GASKET	SS304+Flexible Graphite
9	COVER	ASTM A216 WCB
10	NUT	ASTM A194 2H
11	BOLT	ASTM A193 B7
12	GASKET	COPPER ALLOYS
13	DRAIN PLUG	CARBON STEEL

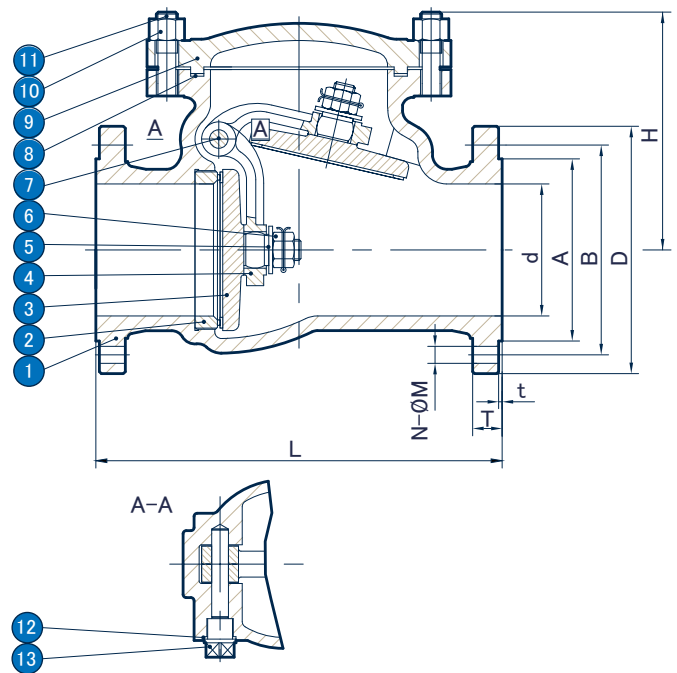

## Dimensions (mm):

SIZE		d	L	H	T	t	A	B	D	N-ØM	Weight kg
IN	DN										
2"	50	49	292	155	26	6.4	92	127	165	8-Ø19	24
2½"	65	62	330	178	29	6.4	105	149	190	8-Ø22	35
3"	80	74	356	200	32	6.4	127	168	210	8-Ø22	45

Note: Torque measured at ambient temperature with no loading ; safety factor is not included.

# CHECK VALVE

Cast Steel Swing Check Valve  
CLASS 600, 4"~24"

MODEL: KRD-SCF

## » Features

- Suitable for a wide range of industry and media
- Precision, high quality castings
- Suitable for both horizontal and vertical installation
- Bolted cover; robust construction
- EN10204-3.1 Material certificate available

## » Standards

- Basic design to API6D
- Face-to-face acc. to B16.10
- End flange dimension acc. to B16.5
- Inspection & test acc. to API 598

## » Temperature Range

Metal seat : -29°C to 450°C

## » Limitation

- If installed in a vertical position, the direction of flow must be in an up-flow direction
- If installed in a horizontal position, the valve must be installed with the cover oriented to the top

## Materials List:

NO	PART NAME	MATERIAL
1	BODY	ASTM A216 WCB
2	SEAT RING	ASTM A105+13Cr
3	DISC	ASTM A216 WCB+13Cr
4	HINGE	ASTM A216 WCB
5	DISC WASHER	AISI 1025
6	DISC NUT	ASTM A194 2H
7	HINGE PIN	ASTM A276 410
8	GASKET	SS304+Flexible Graphite
9	COVER	ASTM A216 WCB
10	NUT	ASTM A194 2H
11	BOLT	ASTM A193 B7
12	HOOK SCREW	CARBON STEEL
13	GASKET	COPPER ALLOYS
14	DRAIN PLUG	CARBON STEEL

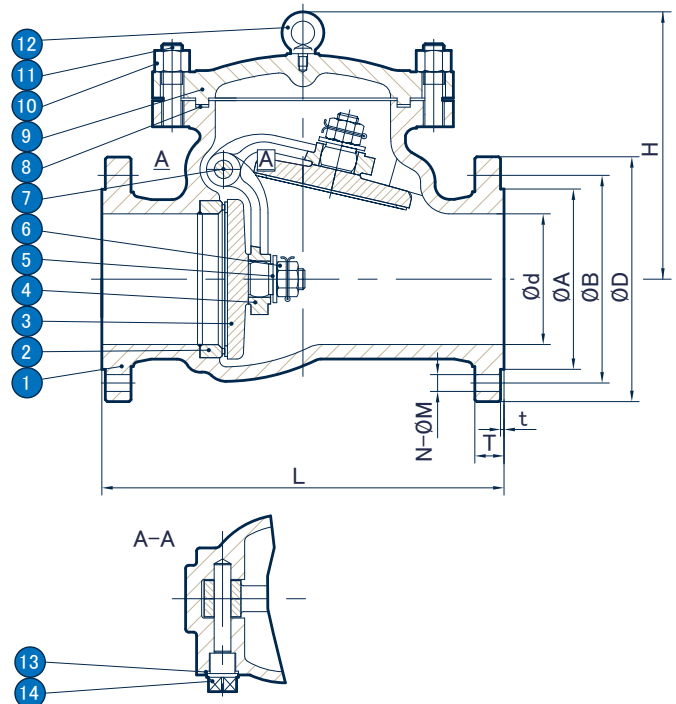

## Dimensions (mm):

SIZE		d	L	H	T	t	A	B	D	N-ØM	Weight kg
IN	DN										
4"	100	100	432	280	38	6.4	157	216	273	8-Ø25	91
6"	150	150	559	362	48	6.4	216	292	356	12-Ø29	191
8"	200	201	660	437	56	6.4	270	349	419	12-Ø32	343
10"	250	252	787	490	64	6.4	324	432	508	16-Ø35	618
12"	300	303	838	528	67	6.4	381	489	559	20-Ø35	850
14"	350	334	889	572	70	6.4	413	527	603	20-Ø38	920
16"	400	385	991	660	77	6.4	470	603	686	20-Ø41	1195
18"	450	436	1092	720	83	6.4	533	654	743	20-Ø44	1820
20"	500	487	1194	746	89	6.4	584	724	813	24-Ø44	-
24"	600	589	1397	960	102	6.4	692	838	940	24-Ø51	-

Note: Torque measured at ambient temperature with no loading ; safety factor is not included.

# CHECK VALVE

Cast Steel Swing Check Valve  
CLASS 600, 26"

MODEL: KRD-SCF

## » Features

- Suitable for a wide range of industry and media
- Precision, high quality castings
- Suitable for both horizontal and vertical installation
- Bolted cover; robust construction
- EN10204-3.1 Material certificate available

## » Standards

- Basic design to API6D
- Face-to-face acc. to B16.10
- End flange dimension acc. to B16.5
- Inspection & test acc. to API 598

## » Temperature Range

Metal seat : -29°C to 450°C

## » Limitation

- If installed in a vertical position, the direction of flow must be in an up-flow direction
- If installed in a horizontal position, the valve must be installed with the cover oriented to the top

## Materials List:

NO	PART NAME	MATERIAL
1	BODY	ASTM A216 WCB
2	SEAT RING	ASTM A182 F316
3	DISC	ASTM A216 WCB+13Cr
4	HINGE	ASTM A216 WCB
5	DISC WASHER	AISI 1025
6	DISC NUT	AISI 1025
7	HINGE PIN	ASTM A276 410
8	GASKET	SS304+Flexible Graphite
9	COVER	AISI 1025
10	NUT	ASTM A194 2H
11	BOLT	ASTM A193 B7
12	HOOK SCREW	CARBON STEEL
13	Amortisseur	Components
14	Balancer	Components

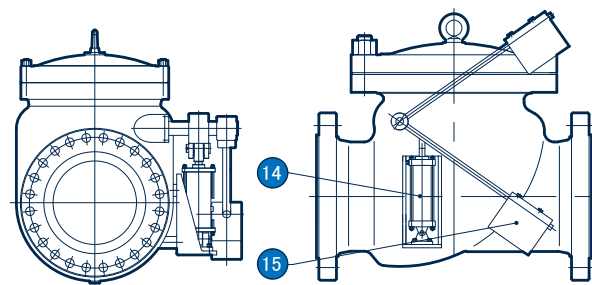
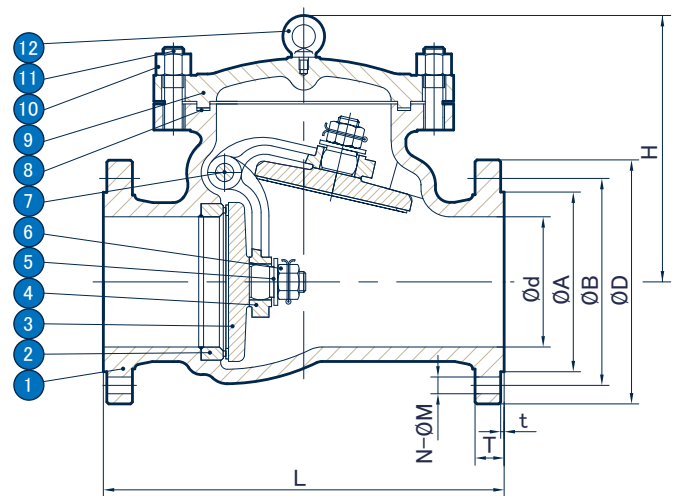

## Dimensions (mm):

SIZE		d	L	H	T	t	A	B	D	N-ØM
IN	DN									
26"	650	633	1448	-	108	2	749	914.4	1015	28-Ø51

# CHECK VALVE

Cast Steel Swing Check Valve  
CLASS 900, 2"~16"

**MODEL: KRD-SCF**

## » Features

- Suitable for a wide range of industry and media
- Precision, high quality castings
- Suitable for both horizontal and vertical installation
- Bolted cover; robust construction
- EN10204-3.1 Material certificate available

## » Standards

- Basic design to API6D
- Face-to-face acc. to B16.10
- End flange dimension acc. to B16.5
- Inspection & test acc. to API 598

## » Temperature Range

Metal seat : -29°C to 450°C

## » Limitation

- If installed in a vertical position, the direction of flow must be in an up-flow direction
- If installed in a horizontal position, the valve must be installed with the cover oriented to the top

## Materials List:

NO	PART NAME	MATERIAL
1	BODY	ASTM A216 WCB
2	SEAT RING	ASTM A105+13Cr
3	DISC	ASTM A216 WCB+13Cr
4	DISC WASHER	AISI 1025
5	DISC NUT	ASTM A194 2H
6	HINGE	ASTM A216 WCB
7	HINGE PIN	ASTM A276 410
8	YOKE	ASTM A216 WCB
9	GASKET	SS304+Flexible Graphite
10	COVER	ASTM A216 WCB
11	NUT	ASTM A194 2H
12	BOLT	ASTM A193 B7
13	HOOK SCREW	CARBON STEEL

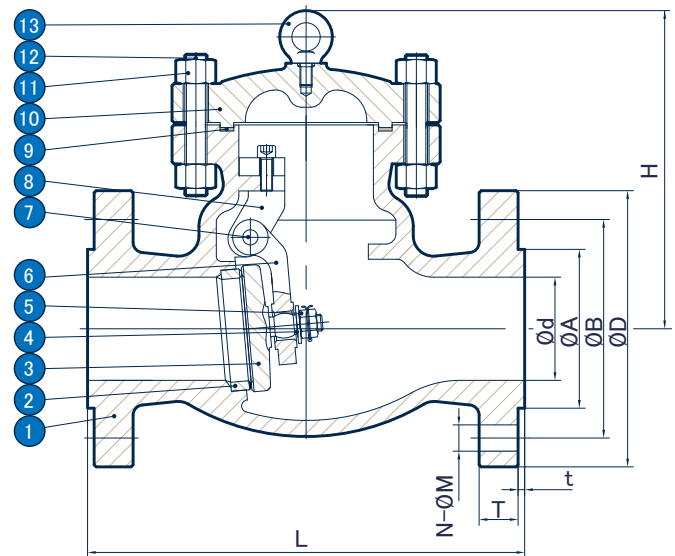

## Dimensions (mm):

SIZE		d	L	H	T	t	A	B	D	N-ØM
IN	DN									
2"	50	47.5	368	280	38.1	7	92	165.1	215	8-Ø25.5
2½"	65	57	419	280	41.3	7	105	190.5	245	8-Ø28.5
3"	80	73	381	280	38.1	7	127	190.5	240	8-Ø25.5
4"	100	98	457	280	44.5	7	157	235	290	8-Ø32
6"	150	148	610	362	55.6	7	216	317.5	380	12-Ø32
8"	200	191	737	437	63.5	7	270	393.7	470	12-Ø38
10"	250	238	838	490	69.9	7	324	469.9	545	16-Ø38
12"	300	283	965	528	79.4	7	381	533.4	610	20-Ø38
14"	350	311	1029	572	85.4	7	413	558.8	640	20-Ø41
16"	400	356	1130	660	88.9	7	470	616	705	20-Ø44.5

# CHECK VALVE

Cast Steel Swing Check Valve  
CLASS 1500, 2"~16"

MODEL: KRD-SCF

## » Features

- Suitable for a wide range of industry and media
- Precision, high quality castings
- Suitable for both horizontal and vertical installation
- Bolted cover; robust construction
- EN10204-3.1 Material certificate available

## » Standards

- Basic design to API6D
- Face-to-face acc. to B16.10
- End flange dimension acc. to B16.5
- Inspection & test acc. to API 598

## » Temperature Range

Metal seat : -29°C to 450°C

## » Limitation

- If installed in a vertical position, the direction of flow must be in an up-flow direction
- If installed in a horizontal position, the valve must be installed with the cover oriented to the top

## Materials List:

NO	PART NAME	MATERIAL
1	BODY	ASTM A216 WCB
2	SEAT RING	ASTM A105+13Cr
3	DISC	ASTM A216 WCB+13Cr
4	DISC WASHER	AISI 1025
5	DISC NUT	ASTM A194 2H
6	HINGE	ASTM A216 WCB
7	HINGE PIN	ASTM A276 410
8	YOKE	ASTM A216 WCB
9	GASKET	SS304+Flexible Graphite
10	COVER	ASTM A216 WCB
11	NUT	ASTM A194 2H
12	BOLT	ASTM A193 B7
13	HOOK SCREW	CARBON STEEL

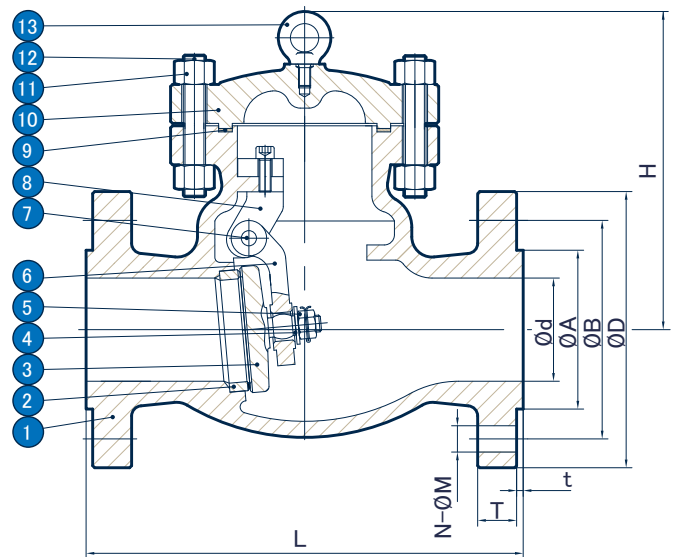

## Dimensions (mm):

SIZE		d	L	H	T	t	A	B	D	N-ØM
IN	DN									
2"	50	47.5	368	280	38.1	7	92	165.1	215	8-Ø25.5
2½"	65	57	419	280	41.3	7	105	190.5	245	8-Ø28.5
3"	80	70	470	280	47.7	7	127	203.2	265	8-Ø32
4"	100	92	546	280	54	7	157	241.3	310	8-Ø35
6"	150	136	705	362	82.6	7	216	317.5	395	12-Ø38
8"	200	178	832	437	92.1	7	270	393.7	485	12-Ø45
10"	250	222	991	490	108	7	324	482.6	585	16-Ø51
12"	300	263	1130	528	123.9	7	381	571.5	675	20-Ø54