

# CHECK VALVE

Cast Steel Lift Check Valve  
PN40-F1, DN15~DN300

**MODEL: KRD-LCF**

» **Body Material**

DIN 17245 GS-C25 + 13Cr

» **Size Range**

1/2" - 12" (DN15~DN300)

» **Temperature Range**

Metal seat : -10°C to 450°C

» **Standards**

- Basic design to DIN 3356
- Face-to-face acc. to DIN 3202-F1
- End flange dimension acc. to EN 1092-1
- Inspection & test acc. to EN 12266-1/2

**Materials List:**

NO	PART NAME	MATERIAL
1	BODY	DIN 17245 GS-C25 + 13Cr
2	DISC	ASTM A105 + 13Cr
3	SPRING	SS304
4	BUSHING	SS304
5	BONNET GASKET	SS304+FLEXIBLE GRAPHITE
6	BONNET	ASTM A105
7	BONNET NUT	ASTM A194 2H
8	BONNET BOLT	ASTM A193 B7

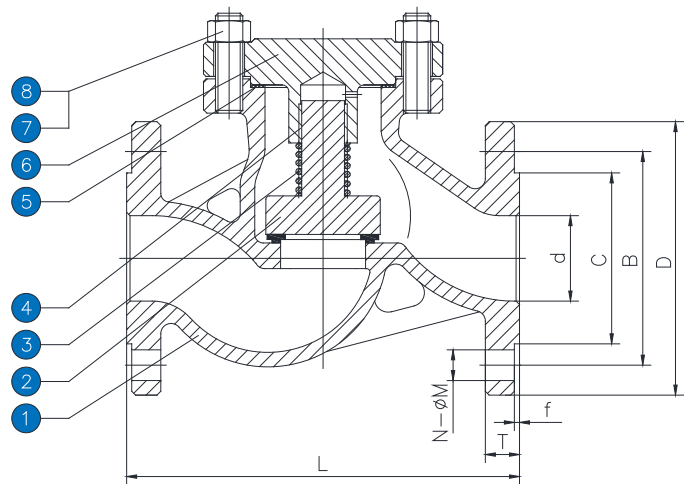

**Dimensions (mm):**

SIZE		d	D	B	C	L	T	f	N	M
IN	DN									
1/2"	15	15	95	65	45	130	16	2	4	14
3/4"	20	20	105	75	58	150	18	2	4	14
1"	25	25	115	85	68	160	18	2	4	14
1 1/4"	32	32	140	100	78	180	18	2	4	18
1 1/2"	40	40	150	110	88	200	18	3	4	18
2"	50	50	165	125	102	230	20	3	4	18
2 1/2"	65	65	185	145	122	290	22	3	8	18
3"	80	80	200	160	138	310	24	3	8	18
4"	100	100	235	190	162	350	24	3	8	22
5"	125	125	270	220	188	400	26	3	8	26
6"	150	150	300	250	218	480	28	3	8	26
8"	200	200	375	320	285	600	34	3	12	30
10"	250	250	450	385	345	730	38	3	12	33
12"	300	300	515	450	410	850	42	4	16	33

# CHECK VALVE

Cast Steel Lift Check Valve  
CLASS 150, 2"~12"

**MODEL: KRD-LCF**

- » **Body Material**  
ASTM A216 WCB
- » **Size Range**  
2" - 12" (DN50~DN300)
- » **Temperature Range**  
Metal seat : -29°C to 450°C
- » **Standards**
  - Basic design to BS 1868
  - Face-to-face acc. to ASME B16.10
  - End flange dimension acc. to ASME B16.5
  - Inspection & test acc. to API 598

**Materials List:**

NO	PART NAME	MATERIAL
1	BODY	ASTM A216 WCB
2	DISC	ASTM A105 + 13Cr
3	SPRING	SS304
4	BUSHING	SS304
5	BONNET GASKET	SS304+FLEXIBLE GRAPHITE
6	BONNET	ASTM A105
7	BONNET NUT	ASTM A194 2H
8	BONNET BOLT	ASTM A193 B7
9	HOOK SCREW	CARBON STEEL

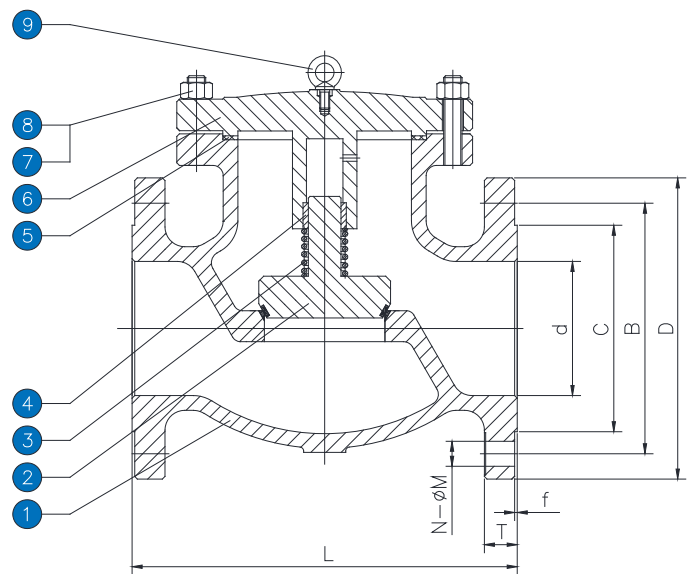

**Dimensions (mm):**

SIZE		d	D	B	C	L	T	f	N	M
IN	DN									
2"	50	49	150	120.7	92.1	203	16.3	2	4	19
2½"	65	62	180	139.7	104.8	216	17.9	2	4	19
3"	80	74	190	152.4	127	241	19.5	2	4	19
4"	100	100	230	190.5	157.2	292	24.3	2	8	19
5"	125	127	255	215.9	185.7	356	24.3	2	8	22.5
6"	150	150	280	241.3	215.9	406	25.9	2	8	22.5
8"	200	201	345	298.5	269.9	495	29	2	8	22.5
10"	250	252	405	362	323.8	622	30.6	2	12	25.5
12"	300	303	485	431.8	381	698	32.2	2	12	25.5

# CHECK VALVE

Cast Steel Lift Check Valve  
CLASS 300, 2"~12"

**MODEL: KRD-LCF**

- » **Body Material**  
ASTM A216 WCB
- » **Size Range**  
2" - 12" (DN50~DN300)
- » **Temperature Range**  
Metal seat : -29°C to 450°C
- » **Standards**
  - Basic design to BS 1868
  - Face-to-face acc. to ASME B16.10
  - End flange dimension acc. to ASME B16.5
  - Inspection & test acc. to API 598

**Materials List:**

NO	PART NAME	MATERIAL
1	BODY	ASTM A216 WCB
2	DISC	ASTM A105 + 13Cr
3	SPRING	SS304
4	BUSHING	SS304
5	BONNET GASKET	SS304+FLEXIBLE GRAPHITE
6	BONNET	ASTM A105
7	BONNET NUT	ASTM A194 2H
8	BONNET BOLT	ASTM A193 B7
9	HOOK SCREW	CARBON STEEL

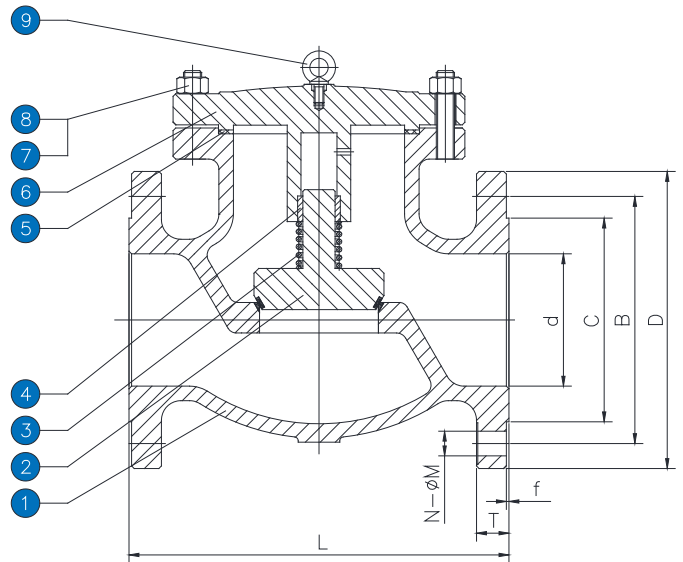

**Dimensions (mm):**

SIZE		d	D	B	C	L	T	f	N	M
IN	DN									
2"	50	49	165	127	92.1	267	22.7	2	8	19
2½"	65	62	190	149.2	104.8	292	25.9	2	8	22.5
3"	80	74	210	168.3	127	318	29	2	8	22.5
4"	100	100	255	200	157.2	356	32.2	2	8	22.5
5"	125	127	280	235	185.7	400	35.4	2	8	22.5
6"	150	150	320	269.9	215.9	444	37	2	12	22.5
8"	200	201	380	330.2	269.9	559	41.7	2	12	25.5
10"	250	252	445	387.4	323.8	622	48.1	2	16	28.5
12"	300	303	520	450.8	381	711	51.3	2	16	32

# CHECK VALVE

Cast Steel Lift Check Valve  
CLASS 600, 2"~12"

**MODEL: KRD-LCF**

- » **Body Material**  
ASTM A216 WCB
- » **Size Range**  
2" - 12" (DN50~DN300)
- » **Temperature Range**  
Metal seat : -29°C to 450°C
- » **Standards**
  - Basic design to BS 1868
  - Face-to-face acc. to ASME B16.10
  - End flange dimension acc. to ASME B16.5
  - Inspection & test acc. to API 598

## Materials List:

NO	PART NAME	MATERIAL
1	BODY	ASTM A216 WCB
2	DISC	ASTM A105 + 13Cr
3	SPRING	SS304
4	BUSHING	SS304
5	BONNET GASKET	SS304+FLEXIBLE GRAPHITE
6	BONNET	ASTM A105
7	BONNET NUT	ASTM A194 2H
8	BONNET BOLT	ASTM A193 B7
9	HOOK SCREW	CARBON STEEL

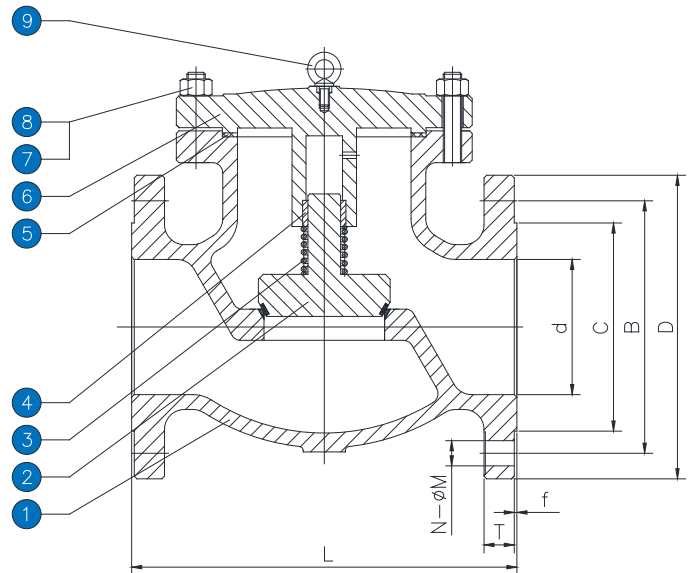

## Dimensions (mm):

SIZE		d	D	B	C	L	T	f	N	M
IN	DN									
2"	50	49	165	127	92.1	292	25.4	7	8	19
2½"	65	62	190	149.2	104.8	330	28.6	7	8	22.5
3"	80	74	210	168.3	127	356	31.8	7	8	22.5
4"	100	100	275	215.9	157.2	432	38.1	7	8	25.5
5"	125	127	330	266.7	185.7	508	44.5	7	8	28.5
6"	150	150	355	292.1	215.9	559	47.7	7	12	28.5
8"	200	200	420	349.2	269.9	660	55.6	7	12	32
10"	250	248	510	431.8	323.8	787	63.5	7	16	35
12"	300	298	560	489	381	838	66.7	7	20	35