

ON-OFF free flow valves

Series VPFL - FL UNI PN 10/16



KLINGER Portugal, Lda. – Via José Régio, 36 | 4485-860 | Vila do Conde

geral@klinger.pt | www.klinger.pt

T: +351 229 470 910

Technical data

Size (DN)	DN 15 - 200
Rating	PN 16 (15-150) - PN 10 (200)
Connections	FLANGES DRILLING PN 16 (15-32) FLANGES UNI PN 10/16 (40-200)
Plug characteristic	Disc
Actuator	Pneumatic with piston
Supply	min 4 / max 8 bar
Temperature	from -30 to +150 °C

Description

Pneumatic valve angle seat with high coefficient of flow, solid construction and compact. Versatility due to the construction of stainless steel for use in harsh environments. They can be employed in several sector as: textile dyeing and finishing plants, chemical plants, water-treating, alimentary, general industrial plants. All Burocco valves are delivered after testing and calibration and ready for a long utilize, without maintenance.

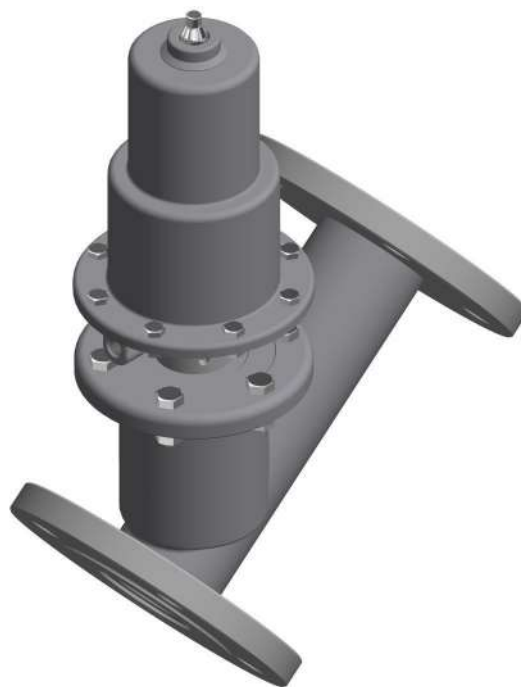

Options

- ⇒ Normally open (NO)
- ⇒ Double effect (DE)
- ⇒ Seals actuator FPM (for steam max 180 °C)
- ⇒ Handwheel for emergency operation
- ⇒ Rate shutter
- ⇒ Mechanical limit switch / proximity / microswitches box
- ⇒ Solenoid
- ⇒ Electropneumatic converter signal 4-20 mA
o 0-10 VDC (control plug)
- ⇒ Special flanges on request (face to face UNI)
- ⇒ Special executions on request

DN	15	20	25	32	40	50	65	80	100	125	150	200
C _v	5	9	14	22	34	53	91	138	217	339	490	865
K _{vs}	4,3	7,7	12	18,8	29	45,3	77,8	118	185,5	290	419	739

ON-OFF free flow valves

Series VPFL - FL UNI PN 10/16



KLINGER Portugal, Lda. – Via José Régio, 36 | 4485-860 | Vila do Conde

geral@klinger.pt | www.klinger.pt

T: +351 229 470 910

Materials	
Valve body	AISI 316/316L
Flanges	AISI 304/304L (STD) AISI 316/316L
Insert plug	PTFE (STD) - PTFE/CG - SILICON
Stem / Plug	AISI 316/316L
Packing	Standard PTFE ring energized with O-ring FPM
Body gasket	PTFE (STD) - CARBOFIBER - ARMED GRAPHITE
Seal actuator	FPM - NBR

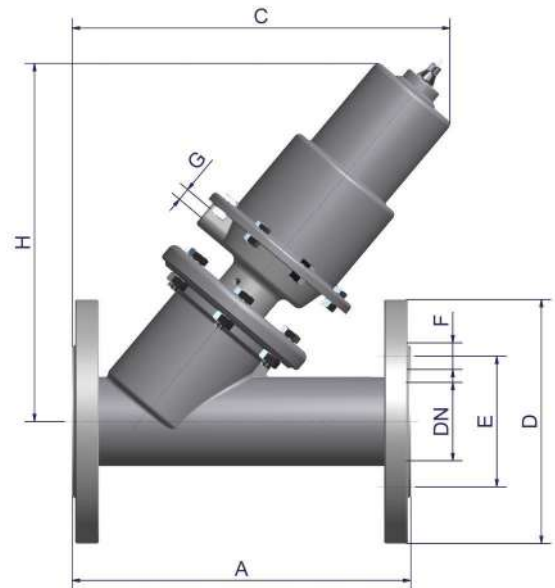

Dimensions (mm)									
DN - servoc.	A	C	D	E	H	F	n° drills	G	weight (Kg) *
15 - S.63	130	190	95	65	190	14	4	1/8" G	3,6
20 - S.63	150	195	105	75	190	14	4	1/8" G	4,0
20 - S.82	150	220	105	75	220	14	4	1/8" G	4,5
25 - S.63	160	195	115	85	190	14	4	1/8" G	4,6
25 - S.82	160	235	115	85	230	14	4	1/8" G	5,1
32 - S.63	180	200	140	100	195	18	4	1/8" G	5,5
32 - S.82	180	225	140	100	220	18	4	1/8" G	7,0
40 - S.82	200	245	150	110	230	18	4	1/8" G	8,5
40 - S.118	200	300	150	110	295	18	4	1/8" G	11,5
50 - S.82	230	255	165	125	245	18	4	1/8" G	10,5
50 - S.118	230	315	165	125	310	18	4	1/8" G	13,0
65 - S.118	290	320	185	145	280	18	4	1/8" G	16,0
65 - S.136	290	345	185	145	305	18	4	1/4" G	19,5
80 - S.136	310	350	200	160	320	18	8	1/4" G	24,0
80 - S.153	310	385	200	160	360	18	8	1/4" G	26,5
100 - S.136	350	385	220	180	335	18	8	1/4" G	29,0
100 - S.153	350	420	220	180	375	18	8	1/4" G	32,0
125 - S.153	400	495	250	210	400	18	8	1/4" G	44,0
150 - S.153	480	545	285	240	425	22	8	1/4" G	44,0
200 - S.235	600	On request	340	295	On request	22	12 **	1/4" G	On request

* Actuator without accessories.

** On request n° 8 drills Ø 22 mm on flanges UNI PN 10.