



KLINGER CORIOLIS

Flow Meter

**USER
MANUAL**



CONTENT

1. General.....	3
1.1. Introduction.....	3
1.2. Principle.....	3
1.3. Feature.....	3
1.4. Measuring system.....	3
2. Technical specifications.....	5
2.1. Main Technical Specification.....	5
2.2. Flow Range.....	5
2.3. Specification of Function.....	8
2.4. Environment Limitation.....	8
2.5. Outline Dimension.....	9
2.6. Weights.....	10
3. Introduction.....	11
3.1. About This Manual.....	11
3.2. Safety.....	11
3.3. Components.....	11
3.4. Installation Process.....	11
4. Installation.....	11
4.1. Position selection.....	11
4.2. Direction.....	12
4.3. Sensor Installation.....	13
4.4. Wiring.....	13
4.5. Start-up.....	18
5. Power Supply and Signal output Wiring.....	18
5.1. Power wiring.....	18
5.2. 4-20mA output wiring.....	20
5.3. Pulse output wiring.....	21
5.4. RS485 output wiring.....	21
5.5. Amplifier wiring.....	21
6. Operation.....	22
6.1. General.....	22
6.2. Key Function.....	22
6.3. Measuring Value Checking.....	22
6.4. Configuration Parameter.....	23
6.5. Calibration.....	25
7. Pressure Drop.....	26
8. Trouble Shooting.....	27
8.1. Overview.....	27
8.2. Diagnostic Tool.....	27
8.3. Sensor.....	28
8.4. Power and connection.....	28
8.5. LED-Indicator.....	28
9. Explosion-proof.....	29
Appendix: Menu Chart.....	30

1. GENERAL

1.1 Introduction

Mass Flowmeter is designed according to the Coriolis Principle. It can be widely used for the process detecting and custody transfer/fiscal unit in many industries such as petroleum, petroleum and chemical, chemical industry, pharmacy, paper making, food and energy, and so on. As a fairly advanced kind of flow measurement instrument, it has been paid attention by the circle of measurement and accepted by many customers home and abroad.

1.2 Principle

Mass Flowmeter is designed according to the principle of Coriolis force. Under the alternating current effect, the magnet and coil installed on the measuring tube will make two parallel measuring tubes vibrate according to some fixed frequency. Once there is flow passing through the pipes, Coriolis force will give rise to deflection (phase shift) on the vibration of two pipes and the deflection of vibration is directly proportional to the mass flow of fluid. Pick up them and the mass flowrate could be calculated.

The vibration frequency of measuring tube is determined by the total mass of measuring tube and inner fluid. When the fluid density changes, the vibration frequency of measuring tube will be also changing, as a result, the fluid density can be calculated.

The temperature sensor installed in the pipeline can pick up the fluid temperature on time under the coordination of measuring circuit.

1.3 Feature

Comparing with the traditional flow measurement method, Mass Flowmeter has following obvious merits:

- » Enable to measure directly mass flow rate of fluid in the pipeline without changing any parameters, which avoids the some measurement error of intermediate links. Its mass flowrate can be high accuracy and good repeatability within bigger range of turndown ratio.
- » Fluid measured can be more extensive, such as the steady uniform flow of common viscosity fluid, the high viscosity fluid, non-Newtonian fluid, slurry containing some solid components and the liquid containing some trace of gas.
- » Due to the small vibration, measuring tube of the Mass Flowmeter can be regards as nonmoving parts, which will reduce the maintenance of flowmeter, enhance the stability and lifetime.
- » Besides the mass flow measurement, the density and temperature and even consistency can also be picked up and output.





1.4 Measuring system

The measuring system consists of a transmitter and a sensor. Two versions are available:

- » Compact version: transmitter and sensor form a mechanical unit
- » Remote version: transmitter and sensor are mounted physically remote from one another



Sensor

	<p>U series</p> <ul style="list-style-type: none"> » Nominal diameter: 10mm-25mm(3/8"-1") » Material: SS316L for measuring tube; SS304 for housing
	<p>U series</p> <ul style="list-style-type: none"> » Nominal diameter:40mm-200mm(1.5"-8") » Material: SS316L for measuring tube; SS304 for housing
	<p>W Series (Micro-bend shape)</p> <ul style="list-style-type: none"> » Nominal diameter:8mm-250mm(1/4"-10") » Material: SS316L for measuring tube; SS304 for housing
	<p>S Series(Super-bend shape)</p> <ul style="list-style-type: none"> » Nominal diameter:50mm-150mm(2"-6") » Material: SS316L for measuring tube; SS304 for housing

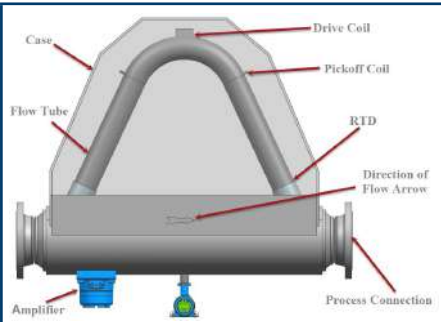

- » Mechanical parts are the same for U/W/S series sensors
- » Amplifier works for the sizes from 100(DN100mm,4") to 300(DN300,12")

2. ESPECIFICAÇÕES TÉCNICAS

2.1 Especificações técnicas principais

DN(mm)	8 ~ 250
Medium	Liquid, gas, slurry
Type / Medium Temp.	Integrate type: (-50 ~ 125)°C Remote type: (-50 ~ 200)°C Remote type with high temp.: (-50 ~ 300)°C Remote type with low temp.: (-150 ~ 125)°C
Sensor	Triangle type, U-type, Micro-bend type
Transmitter	DSP
Certification	Ex-proof
Power Supply	DC24V AC220V
Output Port	RS485
Pressure (MPa)	1.6, 2.5, 4.0, 6.3; Customized for high pressure: 10.0, 16.0, 26.0
Output Signal	4~20mA, pulse
Accuracy	0.1%, 0.15%, 0.2%, 0.5%
Hygienic Type	Customized
Process Connection	Customized

2.2 Flow Range

Table 1: Flow Range for liquid (U Version)

DN	Allowable Flow Range (kg/h)	Normal Flow Range for Accuracy 0.1% (kg/h)	Normal Flow Range for Accuracy 0.2% (kg/h)	Normal Flow Range for Accuracy 0.5% (kg/h)	Stability of Zero Point (kg/h)
10	10~1000	100~1000	70~1000	50~1000	0.03
15	20~3000	300~3000	200~3000	150~3000	0.07
25	80~8000	800~8000	600~8000	400~8000	0.15
40	240~32000	2000~32000	1500~32000	1500~32000	0.9
50	500~50000	3500~50000	2500~50000	2000~50000	1.5
80	800~140000	8000~140000	7000~140000	6000~140000	3.5
100	1500~200000	15000~200000	12000~200000	10000~200000	7
150	5000~500000	50000~500000	35000~500000	28000~500000	17
200	10000~1000000	200000~1000000	120000~1000000	80000~1000000	45
300	25000~2500000	500000~2500000	300000~2500000	200000~2500000	70

Table 2: Flow Range for liquid (Micro-bend Version)

DN	Max. Flow range (kg/h)	Normal flow range for 0.1% accuracy(Kg/h)	Normal flow range for 0.2% accuracy(Kg/h)	Normal flow range for 0.5% accuracy(Kg/h)	Stability of Zero point (Kg/h)
3	1.2~120	10~120	8~120	6~120	0.004
8	8~800	80~800	55~800	40~800	0.035
10	10~1000	100~1000	70~1000	50~1000	0.045
15	20~3000	300~3000	200~3000	150~3000	0.09
25	80~8000	600~8000	400~8000	300~8000	0.25
40	240~24000	2400~24000	1200~24000	1000~24000	1
50	500~45000	5000~45000	2500~45000	2000~45000	2
80	800~120000	10000~120000	8000~120000	6000~120000	3.5
100	1500~200000	20000~200000	15000~200000	10000~200000	7
150	5000~500000	50000~500000	35000~500000	30000~500000	23
200	10000~1000000	100000~1000000	70000~1000000	50000~1000000	45
250	15000~1500000	150000~1500000	120000~1500000	75000~1500000	70

Table 3: Flow Range for Super-bend version

DN	Allowable Flow Range (kg/h)	Normal Flow Range for Accuracy 0.1% (kg/h)	Normal Flow Range for Accuracy 0.2% (kg/h)	Normal Flow Range for Accuracy 0.5% (kg/h)	Stability of Zero Point (kg/h)
50	500~50000	5000~40000	3500~40000	2000~50000	2
80	800~120000	10000~120000	8000~120000	6000~120000	3.5
100	1500~200000	25000~200000	20000~200000	10000~200000	7
150	5000~500000	60000~500000	50000~500000	40000~500000	23

Table 4:

Flow range of volume for air under standard temperature and pressure condition (hereafter we call “standard condition”).
The flow value of other gas medium =

$$\frac{\text{The value in the below table} * \text{Air density under standard condition}}{\text{Medium density under standard condition}}$$

DN (mm)	Start Flow (Nm ³ /h)	Flow Range with Accuracy 0.5% (Nm ³ /h)
15	12.50	62.5 ~ 2500.0
25	33.33	166.7 ~ 6666.7
40	133.33	666.7 ~ 26666.7
50	208.33	1041.7 ~ 41666.7
80	583.33	2916.7 ~ 116666.7
100	833.33	4166.7 ~ 166666.7
150	2083.33	10416.7 ~ 416666.7

The volume under working condition can be calculated by the following formula: Volume flow under working condition =

$$\text{Standard volume flow} \times \frac{0.1}{\text{Working Pressure} + 0.1} \times \frac{\text{Working Temperature} + 273}{273}$$

Note:

- » The unit of working pressure is MPa, the unit of the working temperature is °C.
- » Other gas medium data can be calculated based on above table data * air density under standard condition /medium density under standard condition)

Table 5: Flow rate factor

In many cases, we need to know the flow rate of the medium while using DSP type Mass Flowmeter Mass Flowmeter for gas measurement. The connection size reducing is popular in mass flowmeter gas measurement application, thus the flow rate of Mass Flowmeter Mass Flowmeter (with DSP transmitter) need to be calculated according to the formula below:

$$\text{Medium Flow Rate} = \frac{\text{Volume Flowrate under working condition}}{\text{Flow Rate Factor}}$$

DN (mm)	15	25	40	50	80	100	150
Flow Rate Factor	0362	1.046	3.535	5.436	15.89	26.15	58.84

Note:

1. The gas flow rate is usually much higher than liquid when measured by flowmeter, so there will be noise caused by gas medium and tube wall of flowmeter under high speed gas flow and if the noise become larger, the signal of flowmeter will be influenced, so please use Mass Flowmeter for gas medium measurement at speed less than 1/3 of sound velocity!
2. Please use Mass Flowmeter-Mass Flowmeter for gas with pressure drop not more than 0.2Mpa!

2.2.1 Mass Flow Measuring

- » Flow Range shown in Table 1-4
- » For liquid: Conversion of Basic Error for Mass flow (Table 6)

0.1%	0.2%	0.5%
$\pm 0.1\% \pm \left(\frac{\text{Stability of Zero Point}}{\text{Instant Flow Rate}} \times 100\% \right)$	$\pm 0.2\% \pm \left(\frac{\text{Stability of Zero Point}}{\text{Instant Flow Rate}} \times 100\% \right)$	$\pm 0.5\% \pm \left(\frac{\text{Stability of Zero Point}}{\text{Instant Flow Rate}} \times 100\% \right)$
Accuracy is calculated based on the water measurement under the condition of +20°C~25°C and 0.1MPa~0.2MPa.		

- » Repeatability (Table 7)

Accuracy	0.1% for liquid	0.2% for liquid	0.5% for both of liquid and gas
Repeatability	±0.05%	±0.1%	±0.25%
Accuracy is calculated based on the water measurement under the condition of +20°C~ 25°C and 0.1MPa~0.2MPa.			

2.2.2 Density Measuring (Table 8)

Density Range	(0.2~3.0)g/cm3
Basic Error	±0.002g/cm3 (Affected by the sensor)
Repeatability	0.001g/cm3

2.2.3 Temperature Measuring (Table 9)

Temperature Range	(-50~+125)°C	Integrated Type
	(-50~+200)°C	Separate Type
Basic Error	≤±1.0°C	

2.3 Specification of Function

2.3.1 Current Output (Table 10)

Passive 4 to 20mA Current Output can be configured to denote the mass flow or volume flow or density.

Output Range	(4~20)mA
Resolving Power	0.000244mA
Basic Error	0.2%F.S
Temperature Influence	±0.005%F.S/°C
External resistor should be 250~600Ω	

2.3.2 Pulse/Frequency Output (Table 11)

Active Pulse/Frequency Output can be configured to denote the mass flow or volume flow or density.

Output Range	(0~10)kHz
Resolving Power	0.152Hz
Basic Error	±0.075%
Temperature Influence	±0.001%F.S/°C
Capability of Outrange is 12kHz	

2.3.3 RS485 Output

RS485-Modbus-RTU is optional for each set Mass Flowmeter.

2.3.4 Low Flow Cutoff

When the flow value measured is lower than the value of Low Flow Cutoff, the Mass Flowmeter will output zero flow and the totalizer will stop to accumulate. The value of Low Flow Cutoff is usually sets to be 1% of the maximum flowrate.

2.4 Environment Limitation

2.4.1 Environment vibration (Table 12)

Frequency Range	(10~2000)Hz
Acceleration amplitude value	2g
Circulation time	50 times

2.4.2 Environment temperature (Table 13)

Working Temperature	(-40~+55)°C
Storage Temperature	(-20~+70)°C

2.4.3 Environment humidity (Table 14)

Working Humidity	<90%	+25°C No condensation
Storage Humidity	<95%	

2.4.4 Enclosure Grade:

IP65

2.5 Outline Dimension (See the following Drawings and Tables)

Dimensions of U tube:

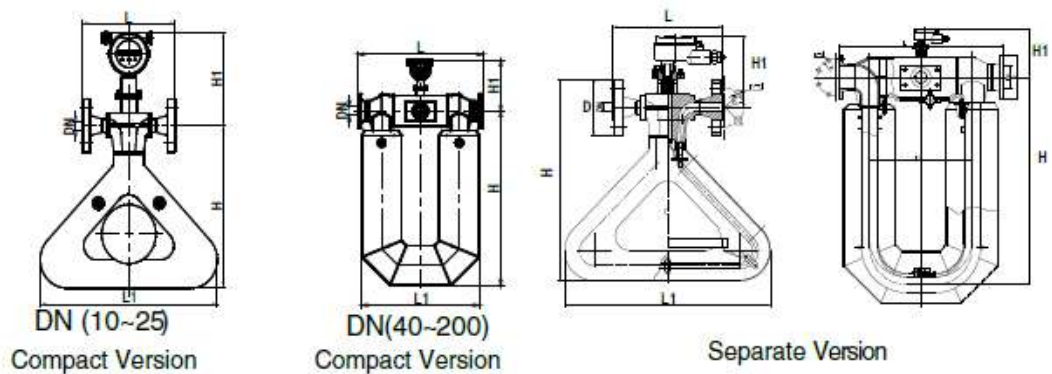

Code	DN	L		L1	H	H1	
		≤ 4.0MPa	≥ 6.3MPa			Integrate	Separate
010	10	150	170	350	290	266	182
015	15	180	194	340	320	266	200
025	25	200	248	450	428	285	200
040	40	520	547	450	660	285	192
050	50	558	588	522	748	277	202
080	80	780	808	705	1030	288	242
100	100	920	948	853	1140	326	272
150	150	1100	1140	1050	1526	356	302
200	200	1364	1410	1160	1655	386	350

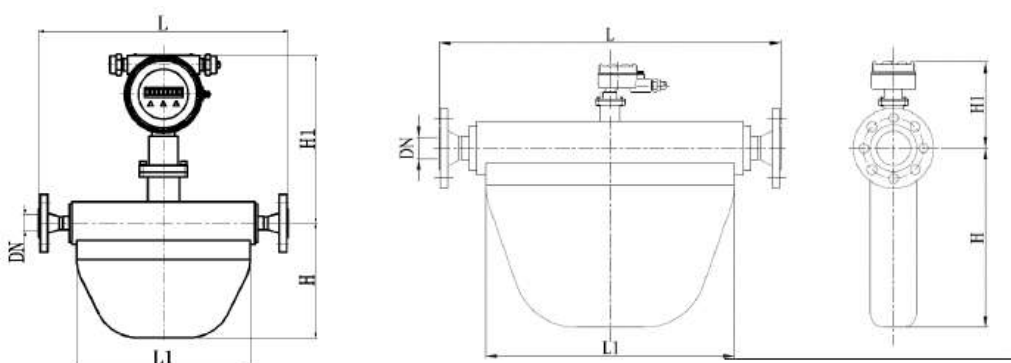

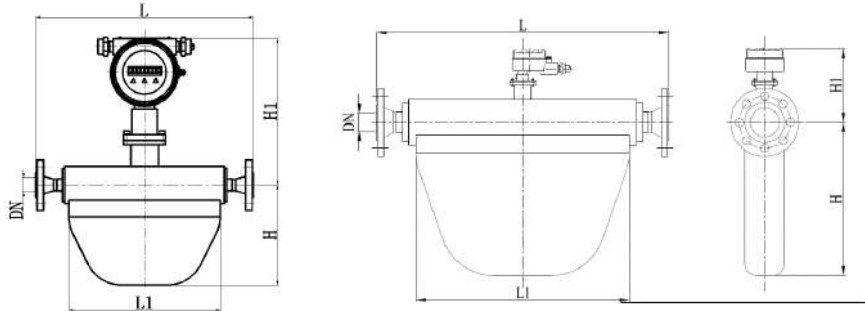

Drawing 5: Micro-bend Version

Mass Flowmeter	DN	Dimensions of Micro-bend type (unit: mm)					
		L		L1	H	H1	
		≤ 4.0MPa	≥ 6.3MPa			Integrate	Separate
008	8	424	484	302	154	270	185
010	10	424	484	302	154	270	185
015	15	400	414	280	191	298	213
025	25	500	536	360	258	302	218
040	40	600	634	460	306	315	230
050	50	800	828	640	410	325	240
080	80	900	928	700	495	350	265
100	100	1130	1156	860	665	370	285
150	150	1410	1450	1200	905	400	316
200	200	1800	1844	1450	1175	426	342
250	250	1966	2006	1530	1300	468	383

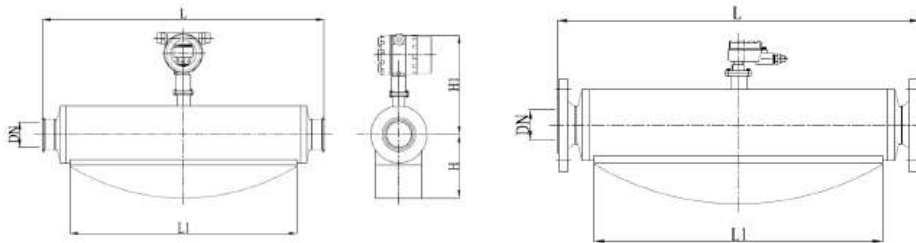

DN	Weight (kg)	Weight (kg)	Weight (kg)	Weight (kg)	Weight (kg)	Weight (kg)	Weight (kg)	Weight (kg)	Weight (kg)
10	10	13	17	30	40	100	190	325	536
15	12	15	25	38	78	135	265	430	

2.6 Weights

DN (mm)	10	15	25	40	50	80	100	150	200
Triangle and U type	10	13	17	30	40	100	190	325	536
Micro-bend type	8	12	15	25	38	78	135	265	430

Note: transmitter for separate type is 5kg.

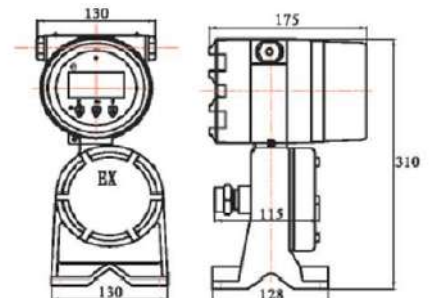

Drawing 6: Dimensions for separate type transmitter (unit: mm)

3. INTRODUCTION

3.1 About This Manual

This manual mainly introduces the installation, connection, startup, operation, and trouble-shooting of Mass Flowmeter. The user must read this manual carefully before use, because improper installation may cause incorrect measurement and even damage the flowmeter.

3.2 Safety

- » When the flowmeter is required to be installed in the dangerous region, please confirm the explosion-proof performance of the flowmeter consistent with the environment in order to avoid the danger.
- » Please ensure that the power goes off to avoid the accident of electric shock when assembling a transmitter.
- » Please defer to the way of installation and usage to ensure the normal operation of the flowmeter.

3.3 Components

Mass Flowmeter is made up of sensor and transmitter, which can be installed integrally or separately. When Mass Flowmeter is installed separately, the sensor and transmitter should be connected through special Nine-Core Cable.

3.4 Installation Process

- » Step 1: Location: Determine the installation location of sensor, which should take the installation area, pipeline, transmitter location and valve into account.
- » Step 2: Direction: Determine the installation direction of sensor in the pipeline.
- » Step 3: Installation: Install the sensor and transmitter in the pipeline.
- » Step 4: Connection: When Mass Flowmeter is installed separately; the sensor and transmitter should be connected through special Nine-Core Cable.
- » Step 5: Start-up.

4. INSTALLATION

4.1 Position selection

1. The sensor should be placed away from interference source which may cause pipe's mechanical vibration such as the pump along the process pipeline. If sensors are used in series along the same line, care must be taken to guard against the mutual influence due to resonance. The distance between sensors should be at least more than three times its width.
2. When installing the sensor, pay attention to the expansion and contraction of the process pipeline due to temperature change. It is strongly recommended that the sensor should not be installed near the expansion joint of the process pipeline. Otherwise, the pipe expansion and contraction of the pipeline will bring about transverse stress which can affect the sensor's zero, as a result of which the measurement accuracy will be affected.
3. The sensor should be placed away from industrial electromagnetic interference sources such as large power motors and transformers, otherwise, the measuring tube's auto-oscillation within the sensor will be interfered, and the weak signal detected by the speed sensor may be drowned by the electromagnetic noise. Therefore, the sensor should be away from such sources as motors and transformers, at least five meters.
4. The sensor should be placed in the position where its measuring tube is always filled with fluids and a certain pressure out is maintained, thus it should be placed in the lower end of the pipeline.

5. Basic requirement: Install the Mass Flowmeter in the lower position of the pipeline so that the fluid can fill with the sensor during the process of zero point calibration and running. The transmitter should be installed in the environment with temperature from -40°C ~ +55°C and humidity <90%.
6. Dangerous area: Please confirm the installation environment is suitable to the explosion-proof performance indicated in the nameplate of Mass Flowmeter for the installation of dangerous area.
7. Straight pipe: Mass Flowmeter does not require the special straight pipe upstream or downstream. However, if two or more mass flow sensors are installed serially in the same pipeline, please ensure the length of pipe between any two sets is more than 2 meters.

4.1.1 Maximum length of cable: (shown in Table 15)

Cable Model	Cable Specification	Max. Length
Special Nine-Core Cable	Special	300m
Current Power Line	18AWG(0.8mm ²)	300m
RS485 Communication Line	22AWG(0.35mm ²)	300m

4.1.2. Working temperature of sensor: (shown in Table 16)

Integral Type	(-50~+125)°C
Separate Type	(-50~+200)°C
High temperature Separate Type	(-50~+300)°C under developing
Low temperature Separate Type	(-150~+125)°C under developing

4.1.3 Valve:

It is necessary to carry through zero point calibration once the installation of Mass Flowmeter is finished. The downstream stop valve has to be close at first before zero point calibration, and then close the upstream stop valve.

4.2 Direction

4.2.1 Basic requirement

The Mass Flowmeter works well only when the liquid fills with the measuring tube. In principle, as long as the measuring tube is full of liquid, the Mass Flowmeter will function in any orientation installation. Generally speaking, the Mass Flowmeter is installed in the orientation which makes the liquid fill with the measuring tube.

For the horizontal installation, the measuring tube should be installed underside the pipeline when the process medium is liquid or slurry (shown on Picture 1) and topside the pipeline when the process medium is gas (shown on Picture 2). For the vertical installation, the measuring tube should be installed besides the pipeline when the process medium is liquid or slurry or gas (shown on Picture 3).

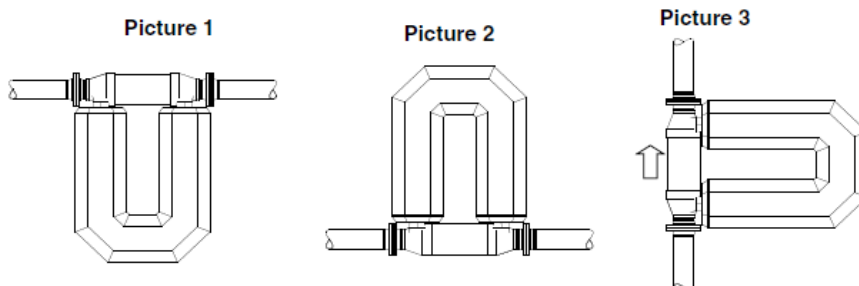

4.2.2 Flow direction

There is obvious flow arrow which indicates the proper flow direction on the front of the sensor, so please install the Mass Flowmeter according to it. Otherwise, the transmitter may not display the mass flow normally.

For vertical installation, if the process medium is liquid or slurry, the flow direction is down-to-up; if the process medium is gas, the flow direction can be either down-to-up or up-to-down. The transmitter can be mounted with 90° revolution according to the requirement of installation.

4.3 Sensor Installation

4.3.1 Basic requirements

The installation of the Mass Flowmeter should decrease the tortuosity of the process connection. Meanwhile, do not support the pipeline by the sensor of the Mass Flowmeter. (Shown in Picture 4)

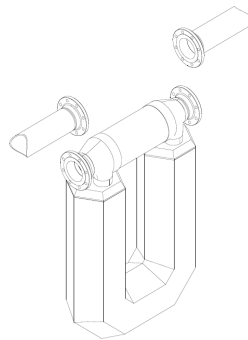

4.3.2 Installation of the Mass Flowmeter-150 Sensor:

It is better to support the sensor of Mass Flowmeter using rubber connector as the buffer.

4.4 Wiring

Overview of the transmitter(Same for both integrate & remote type)

No.	Position of thread	Pitch	Thread form + quality of pitch	Threads engaged	Thread length
(1) Case	Thread on front cover	2mm	Medium, 6h	≥6	25mm
(1) Front cover	Thread on front cover	2mm	Medium, 6h	≥6	25mm
(2) Case	Thread on back cover	2mm	Medium, 6h	≥6	25mm
(2) Back cover	Thread on back cover	2mm	Medium, 6h	≥6	25mm
(3) A/F	Thread for cable gland 1/2" NPT	1.814mm	Medium, 6h	≥6	15mm
(4) A/F	Thread for case	1.5mm	Medium, 6h	≥6	26mm

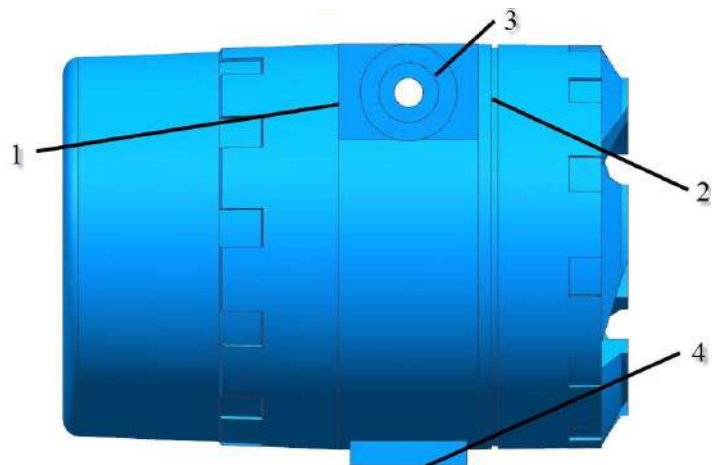



4.4.1 Wiring for Coriolis mass flowmeter

4.4.1.1 Specifications for wiring cables

Cables must fulfill the requirements set forth in EN/IEC 60079-14.

The wiring cables of the flowmeter are divided into three parts: nine-core shielded cable, power cable and output cable.

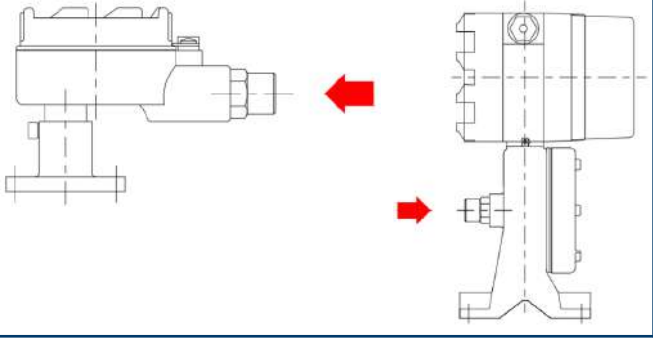
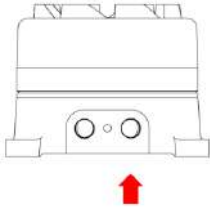
The specifications are as follows, shown in Table below.

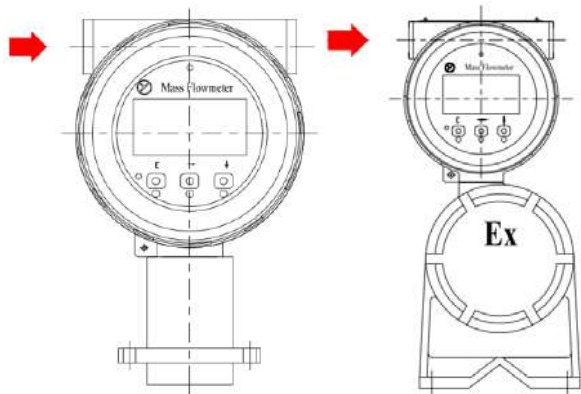
Table Cable specification				
Cable Model	Cable Specification	Max. Length	Gland type	Position of Use
Nine-Core shielded cable		≤100m	DY-02-NPT 1/2" (IECEX CQM 15.0012X/ DNV 13 ATEX 2460X)	
Power cable	1~2.5 mm ²	AC85~250V power supply ≤300 m	DY-02-M20×1.5	
		DC 18~30V power supply ≤100 m	DY-02-NPT 1/2" (IECEX CQM 15.0012X/ DNV 13 ATEX 2460X)	
Output cable	20AW-G(0.5mm ²)	Pulse output, ≤100 m	(4 ~ 20)mA current output, ≤500m	
			RS485 output, ≤300m	

Note: The Nine-Core shielded cable and explosion-proof cable gland will be matched.

4.4.1.2. Wiring of integrated flowmeter

Using the matched gland DY-02-NPT 1/2", choose the appropriate inner diameter of rubber sealing ring according to the diameter of the power cable. And using a three-core power cable, the cross-sectional area of the single wire is about 1~2.5 mm².

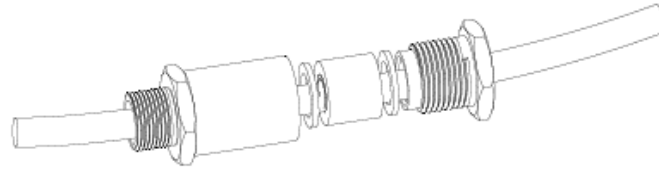

Fig.4.3 The operation of gland

Pass the power cable through the parts of the explosion-proof gland in order according to the wiring method in Figure 4.3. Then pass one end of the power cable through the right interface of the transmitter, fixed the power cable with a screwdriver according to the instructions on the power wiring board, as shown in figure 4.4. After installation, tighten the clamping nut with a wrench to complete the power cable connection, as shown in figure 4.5, and applied 13.0N.m torsion to the clamping nut to tighten it.

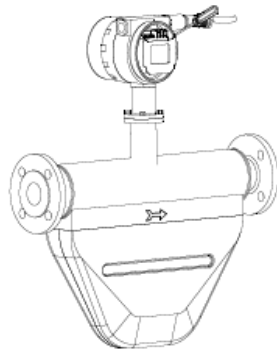

Fig.4.4 The wiring of power cable

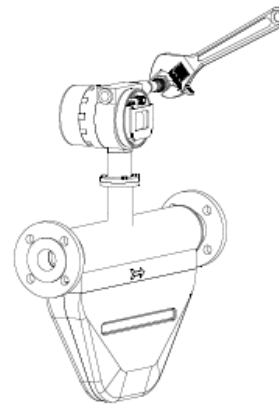

Fig.4.5 The installation of power cable

Operate as above, complete the signal line access. The wiring after installation is shown in figure 4.6.

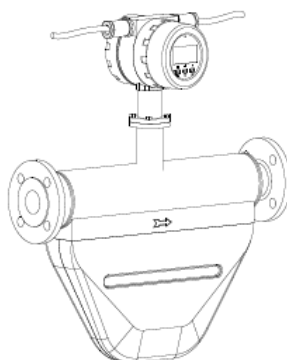

Fig.4.6 The wiring of transmitter

NOTE: If the KLG-MF (DN≥100) is installed, it is required that the drive-amplifier of sensor is supplied with power connection.

4.4.1.3 Wiring of Remote flowmeter

If the sensor is installed separately with the transmitter, the nine-core shielded cable is required to connect with transmitter and sensor. The wiring of the remote transmitter power cable is the same with the compact type transmitter, but the connection to the sensor still requires a 5m dedicated nine-core cable, as shown in figure 4.7.

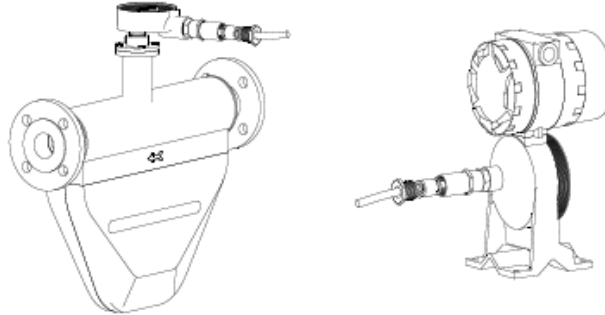

Fig.4.7 The connection of split transmitter and sensor

If a longer dedicated nine-core cable is required, please contact your local office for purchase.

4.4.1.4. Nine-core shielded cable connection

Cut off the power supply before installing the nine-core shielded cable. Stripped about 60mm of cable jacket. Remove the filling material between the metal foil and the wire around the insulated wire, retained a length of about 10mm metal foil, and separate the wires. Combined the shield wires and wrapped twice on the exposed foil. Remove the insulation from each wire end, the stripped cable is as shown in figure 4.8.

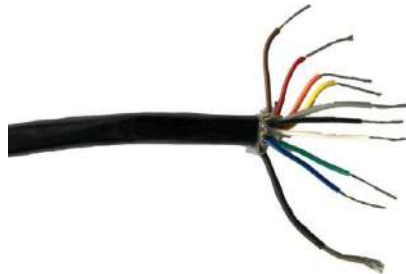

Fig.4.8 The stripped cable

Pass the cable through the explosion-proof gland and the adapter, split terminal box wiring port, the wire ends are crimped according to the color of the cable on the corresponding terminal block. Connect the combined shield wires to the grounding screw of the junction box, as the figure 4.9 shows.



Fig.4.9 Nine-core shielded cable connection

The bending radius of the nine-core shielded cable is greater than or equal to 120mm.

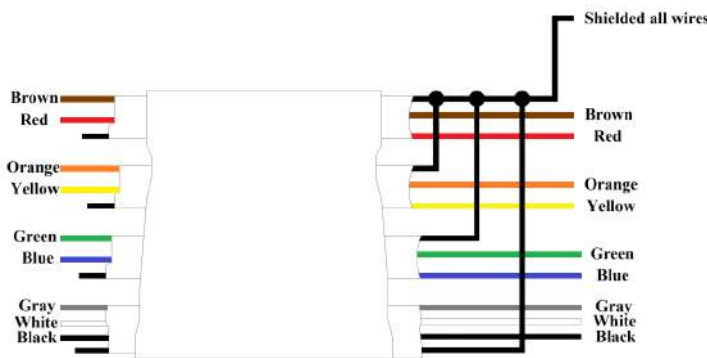



Fig. 4.10 Nine-core shielded cable connection

Table 4.1 Nine-core cable color and function		
Wire No.	Wire Color	Function
1	Brown	The left coil+
2	Red	The left coil-
3	Orange	The right coil+
4	Yellow	The right coil-
5	Green	Driving coil+
6	Blue	Driving coil-
7	Gray	Temperature+
8	White	Temperature-
9	Black	Temperature compensation



Caution

Cut off power before connecting cables. The power voltage must match that indicated in the junction box of the transmitter and the earth connector must be well connected with earth wire to ensure its intrinsic safety performance.

4.4.1.5. Installation of remote mass flowmeter

Before installing the remote mass flow transmitter in the hazardous area, make sure that the transmitter is installed in an environment suitable for the explosion-proof performance indicated on the nameplate of the transmitter and properly installed. The mass flow transmitter should be installed in the temperature (-20 ~ +55)°C , humidity ≤90%. Remote-type mass flow transmitter can be placed on a flat surface, according to the installation needs, and adjust the installation angle.

4.4.1.6 Grounding

- » Both of the sensor and the transmitter have to be ground correctly, otherwise the measurement error will occur and even the KLG-MF may not work. If the pipeline is connected with the ground, the transmitter can be earthed through the pipeline; if the pipeline is not connected with the ground, the transmitter should be earthed independently.
- » The ground wire is as short as possible, impedance is less than 1Ω. The cross-sectional area of the internal ground wire must be greater or equal to the power cable. Internal grounding reference identification operation as show in figure 4.12. In figure 4.12 a, for transmitter had used a wire (cross-sectional area 2.5mm²) connected the internal ground screw to the pin 'FG' of power terminal, and user just need to tighten the ground wire of three-core power cable to the power terminal as figure 4.11. In figure 4.12 b, twist the shielded wire of the nine-core wire and connected it to the internal grounding insert. And in figure 4.12 c, use one of the three-core power cable as a ground wire connected to the insert.
- » The cross-sectional area of the external grounded wire must be ≥ 4mm², and the external grounding position is shown in figure 4.13 below.

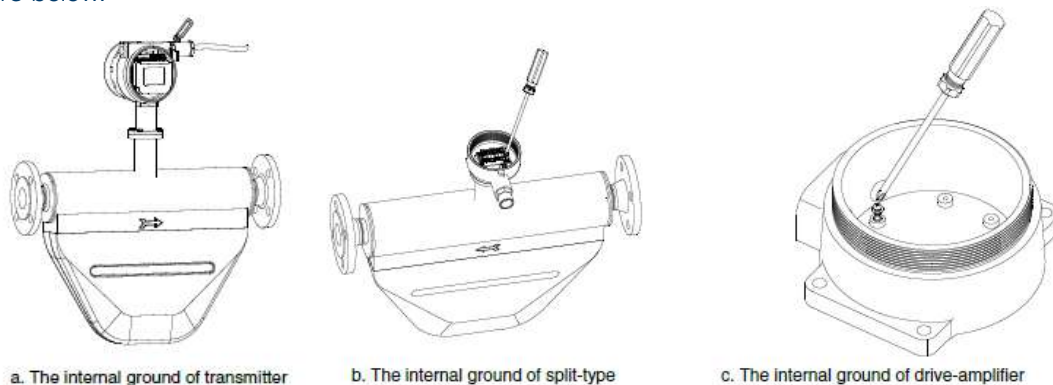

Fig. 4.12 Internal grounding

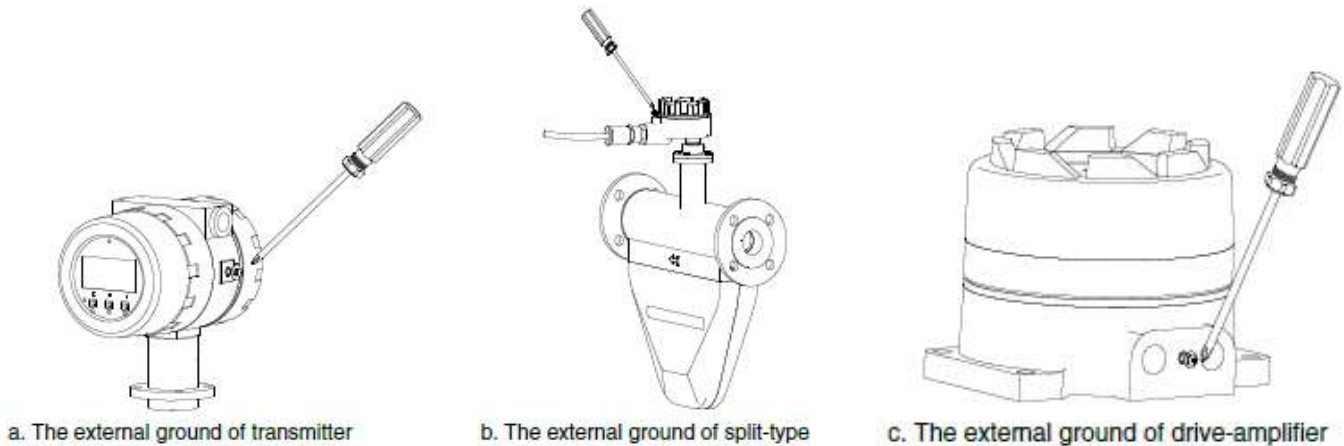

Fig. 4.13 External grounding

Specific grounding method can refer to the corresponding national standard or follow the use of factory standards.

4.5. Start-up

4.5.1 Zero-point calibration

Please see 6.5.1 for details.

4.5.2 Instrument coefficient

Each set of the Mass Flowmeter has its own instrument coefficients, which have been set before delivery and shown on the calibration certificate. So the user does not need to set instrument coefficient except either the sensor or the transmitter is replaced. All the coefficients which can be found on the certificate on the sensor, are also typed on the name plate.

Generally, the sensor and the transmitter are in couples, and the coefficient has been input into the transmitter. The meter can be used without additional change.

5. POWER SUPPLY AND SIGNAL OUTPUT WIRING

5.1 Power wiring

5.1.1 The basic requirement

The transmitter can be connected to the AC220V or the DC24V power.

- » AC (85 to 265) - V Power Consume: Normal 10 W, MAX 15W
- » DC (18 to 30) - V Power Consume: Normal 10 W, MAX 15W

5.1.2 Power Cable

The power cable should choose 2-core cable and the area of each core >0.8 square millimeter. For AC220V, the length of the power cable should be ≤300m, for DC24V, the length of the power cable should be ≤100m.

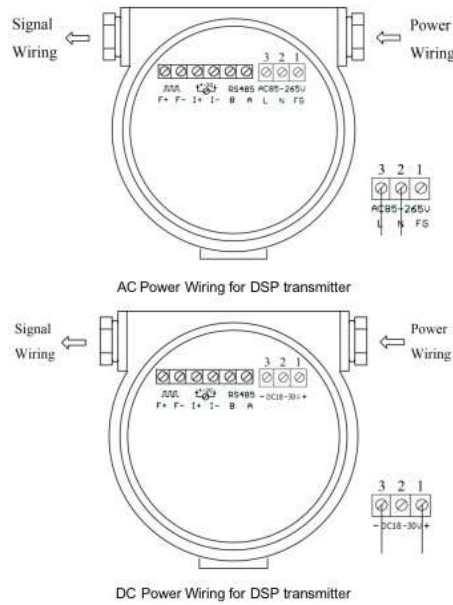

5.1.3 4-20mA output wiring

- » 4~20mA Passive output can be configured to mass flow or volume flow.
- » The cable should choose 2-core cable and the area of each core > 0.5 square millimeter.

ATTENTION!
CFM-MF Series transmitter default status is 4~20mA Passive output!

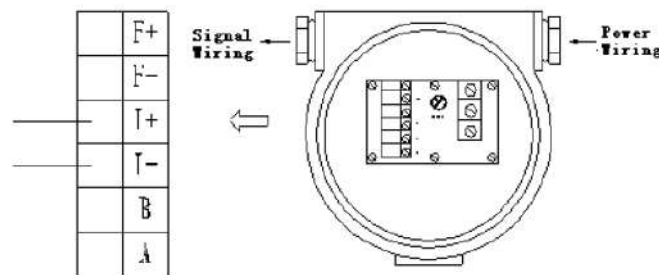

Figure 5.2

26

5.1.4. 4~20mA current output terminal block

I+ is the current input of the Mass Flowmeter;
I- is the current output of the Mass Flowmeter; The illustration is in Figure 1:

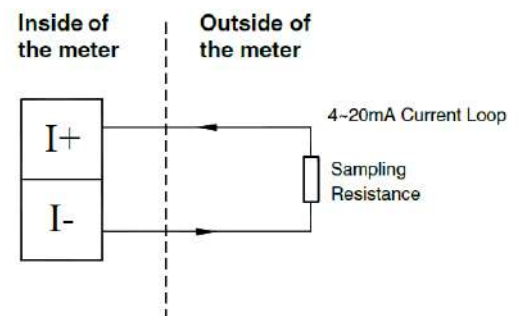

Figure 5.3

5.1.5. Active Output and Passive Output

Active Output is that the current output is powered by the Mass Flowmeter itself. Only the sampling resistance is needed while collecting the current output signal. The illustration is in Figure 2:

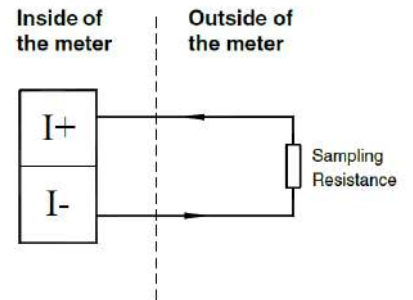

Figure 5.4

Passive output is that besides the sampling resistance, the outer power supply of 24VDC must be added so as to get the current output from the mass flowmeter. The illustration is in Figure 3:

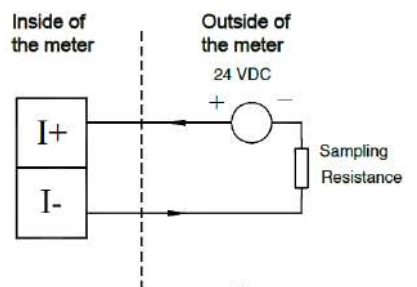
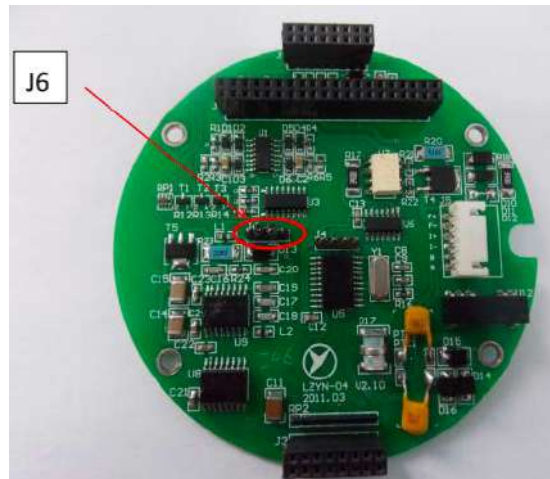

Figure 5.5

5.2 4-20mA output wiring

The switch between passive current output and active current output is realized by setting the jumpers of J6 on the output board(including 070401, 04V1.00, 04V1.01, 04V1.02, 04V1.03).



If active current output is required, we need to short-circuit jumper 1 and 2, then jumper 3 and 4 as well. The illustration is in Figure 4:



Figure 5.6

If passive current output is required, we need to short-circuit jumper 2 and 3. The illustration is in Figure 5:



Figure 5.7

Active and passive current output

- » Active current output is that the devices such as transmitters and signal generators have already been supported by power supply circuit of their own, so the 4~20mA signal could be directly output from the positive and negative terminal blocks, forming a signal circuit with the signal collecting device, which could measure the signal directly in this way.
- » Passive current output is that the devices like the transmitters and signal generators have no supporting power supply circuit of themselves. Only when the signal collecting device could provide additional power supply to them, the 4~20mA signal could be output to be measured by the signal collecting device.

5.3 Pulse output wiring

- » Active pulse output can be configured to mass flow or volume flow or density. The output cable should be 2-core cable and the area of each core is > 0.5 square millimeter.
- » The length of output line should be ≤150m.

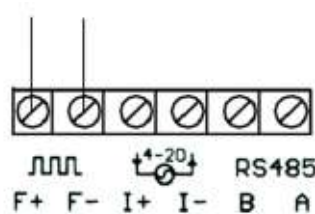

5.4 RS485 output wiring

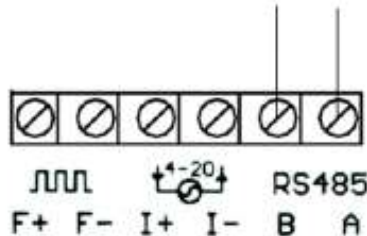

5.5 Amplifier wiring

For the sensor size over 100mm(4”), it needs additional the power supply for the amplifier, which is the same power type with sensor. The power could be AC(85~260)V or DC(18~36)V. Please double check the power type in the nameplate on the sensor. For AC220V, the length of the power cable should be ≤300m, for DC24V, the length of the power cable should be ≤100m, and choose 2-core cable and the area of each core >0.8 square millimeter. Pic 3-6 for the wiring.

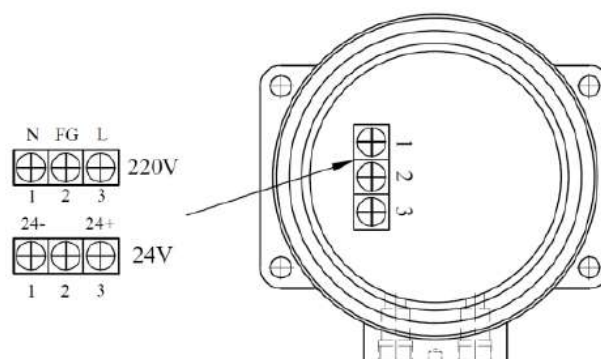

Picture 3-6 Wiring for amplifier

6. Operation



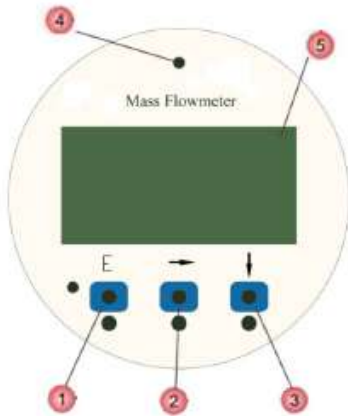

6.1 General

Please use the operation panel of transmitter to set the configuration, such as basic configuration parameters, zero calibration, cutoff value of low flow and output range of current frequency, etc. The panel of the transmitter is shown as below:



No.	Notes
1	E key: enter
2	→ key: move curse or return
3	↓ key : page down
4	Light for working status
5	Two line OLED

6.2 Key Function

Key	Measurement State	Menu State	Function State	Data State
	Show the measurement results and state on Page1/2/3. Page down to menu state.	Next Menu	Select Function	Change number Change unit Change character
	Return to the last screen	Return to the upper-level menu, press the key	Select Function	Move the cursor right
		several times to return to the measurement state		
		Enter the Menu	Confirm and Save the function	Save the input, choose Yes or No, then back to function menu



Note 5:
Operation point of Photoelectric Key is located right behind the glass panel. It is better to operate the photoelectric key in vertical direction, rather than horizontal direction.

6.3 Measuring Value Checking

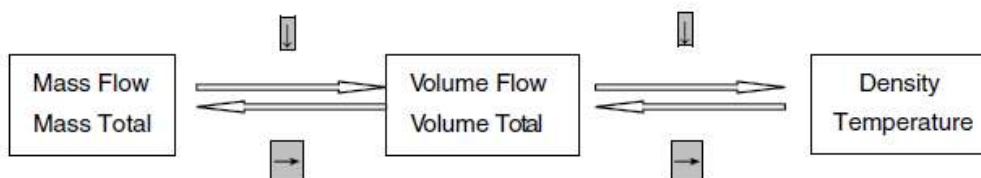

6.4 Configuration Parameter

Please review or set the configuration parameters according to the following indications (press ↓ page down and press → to move the position of cursor or return):

6.4.1 Measurement Unit

Configuration → **E** → **PassWord** (Default password is 000000) → ↓ → **Output Config**
→ ↓ → **Unit Config** **E** → **Mass Unit** or **Mass Flow Unit** or **Volume Unit** or
VolumeFlowUnit or **Density Unit** → **Density Unit** → **E** → Set the units

6.4.2 Reset Totalizer

Configuration → **E** → **PassWord** (Default password is 000000) → **Flow Config** → **E** →
Zero Calibration ↓ → **Low Flow Cutoff** → → → **Reset Totalizer** → → → **Yes** →
E → Reset the mass total to zero.

6.4.3 Low Flow Cutoff

Configuration → **E** → **PassWord** (Default password is 000000) → **Flow Config** → **E**
→ **Zero Calibration** ↓ → **Low Flow Cutoff** → → → ↓ (The number can be set from
0 to 9) → **E** → → → **Yes** → **E** (confirm and save the modification of low flow cutoff)

6.4.4 Current Output

Set the flow rate for 20mA

Configuration → **E** → **PassWord** (Default password is 000000) → ↓ → **Output Config**
→ **E** → **Pulse Weight** → ↓ → **Pulse Output** → ↓ → **20mA Value** → **E** → Set the
flow rate for 20mA

Set current output signal

Configuration → **E** → **PassWord** (Default password is 000000) → ↓ → **Output Config**
→ **E** → **Pulse Weight** → ↓ → **Pulse Output** → ↓ → **20mA Value** → **Current**
Output → **E** → Choose the current output as mass flow (Default), volume flow, density or
water content.

6.4.5 2 nos Current Output

There are two current configuration in the program

» Set the flowrate for 20mA

Configuration → **E** → **PassWord** (Default password is 000000) → ↓ → **Output Config**
→ **E** → **Pulse Weight** → ↓ → **Pulse Output** → ↓ → **1)20mA Value** → **E** → Set the flow
rate for 20mA
→ **E** → **Pulse Weight** → ↓ → **Pulse Output** → ↓ → **2)20mA Value** → **E** → Set the flow
rate for 20mA

» Set current output signal

Configuration → E → **PassWord** (Default password is 000000) → ↓ → **Output Config**
 → E → **Pulse Weight** → ↓ → **Pulse Output** → ↓ → **1)20mA Value** → **Current Output**
 → E → Choose the current output as mass flow (Default), volume flow, density or water content.
 → E → **Pulse Weight** → ↓ → **Pulse Output** → ↓ → **2)20mA Value** → **Current Output**
 → E → Choose the current output as mass flow (Default), volume flow, density or water content.

6.4.6 Pulse/Frequency Output

» Set Pulse Equivalent

Configuration → E → **PassWord** (Default password is 000000) → ↓ → **Output Config**
 → E → **Pulse Weight** → E → **Set Pulse Equivalent**

» Set Pulse Signal

Configuration → E → **PassWord** (Default password is 000000) → ↓ → **Output Config**
 → E → **Pulse Weight** → ↓ → **Pulse Output** → E → Set the pulse output signal as mass flow
 (Default), volume flow, density or water content.

6.4.7 RS485 Output

Configuration → E → **PassWord** (Default password is 000000) → ↓ → **Output Config**
 → E → **Pulse Weight** → ↓ → **Pulse Output** → ↓ → **20mA Value** → ↓ → **Current Output**
 → ↓ → **MODBUS Address** (Set the MODBUS address) → ↓ → **Baud Rate** (Set the baud rate)
 → ↓ → **Parity Bit** (Set the parity bit) → ↓ → **Stop** → **Bits** (Set the stop bits)

6.4.8 First Menu

First menu: The screen will automatically display the content chosen in “First menu” if the no key operation happened to the transmitter within 128 seconds.

Configuration → E → **PassWord** (Default password is 000000) → ↓ → **Output Config**
 → E → **Unit Config** → ↓ → **PressureComo** → ↓ → **Other** → ↓ → E → ↓ → **Output**
AUTO Sim → ↓ → **FlowSimulate** → ↓ → **Flow Sim Start** → ↓ → **First Menu** → ↓ → E
 → Set the “first menu” as Mass(Mass interface), Volume(Volume Interface) or not change (The screen will not automatically switch to any other interface)

6.4.9 Oil and Water Content Analysis

Configuration → E → **PassWord** (Default password is 000000) → ↓ → **Output Config**
 → E → **Unit Config** → ↓ → **PressureComo** → ↓ → **Other** → ↓ → **Addons Function** →
 ↓ → E → ↓ → **OW AnalyseSwitch** (Set the density of the oil in the mixture) → ↓ → **20°C**
 → ↓ → **WaterDen g/mL** (Set the density of the water in the mixture)

6.4.10 Zero Calibration

Configuration → E → **PassWord** (Default password is 000000) → **Flow Config** → E → **Zero Calibration** → E → → → **Yes** → E → Start zero calibration (The zero calibration will finish after 30s)

6.5 Calibration

Generally speaking, the Mass Flowmeter does not need the field calibration for the user because it has been calibrated before delivery.

Each set of Mass Flowmeter has its own instrumental coefficient, including one flow coefficient and four density coefficients (high density D1, high period K1, low density D2 and low period K2), which will be shown in Nameplate of Sensor or Calibration certificate.

The sensor and transmitter are usually delivered as a pair and instrumental coefficient has been set in transmitter so the user does not need to change any longer.

6.5.1 Zero Calibration

Zero calibration provides the datum mark of flowmeter for flow measurement. It is necessary to carry through zero calibration when the Mass Flowmeter is finished to install for the first or a second time.

After correct installation, the Mass Flowmeter should be powered at least 30 minutes for warmup and then make the liquid pass through the flowmeter until the temperature of Mass Flowmeter is same as working temperature of liquid. Afterward, close the downstream valve, make the liquid pass through the flowmeter under normal temperature, density and pressure and then close the upstream valve to assure the sensor is full of liquid during the process of zero calibration.

Finally, press **Configuration** → **Zero Cal** → **Flow configuration** → **Zero Correction** → E → Input password to start zero calibration

6.5.2 Flow Calibration

The mass measured by the Mass Flowmeter is resulted from the multiplication of detected signals' time difference between two circuits and flow calibration factor. When the accuracy is not up to grade after long-term service, please modify the flow calibration factor according to the following formula:

$$K1 = K0 \times [1 + (M - Mt) / Mt] = K0 \times M / Mt$$

Note:

K1 New flow calibration factor,

K0 Old flow calibration factor,

M Total mass flow of Master Meter,

Mt Total mass flow of Tested Meter.

7. Pressure Drop

Pressure drop of flow meter is the unrecoverable pressure loss resulting from the resistance of the flow. The flow path of the mass flow meter is relatively complex and always with reducing pipe. So the pressure drop is a very important factor and can't be ignored.

Pressure drop of mass flow meter is dependent upon the fluid characteristics, the flow state and the structural parameters of the sensor. When the fluid density, viscosity and flow rate are fixed, the pressure drop is only relevant to the structural factors of the sensor part, such as diameter, cross-sectional area of the flow tube, flow tube shape etc.

The reducing pipe is inevitable for the design and manufacture of the mass flow meter. The total cross-sectional area of the two flow tubes is less than the cross-sectional area of the flange. Thus the velocity increases when the fluid enters the mass flow meter. The maximum flow velocity is a very important factor for the industrial control, and the flow velocity affects the technological process and safety etc. As a result, some users may have the requirement of the upper limit of the flow velocity.

When the viscosity is between two adjacent Pressure Drop lines, the Pressure Drop can be calculated with following formula:

$$\Delta P = \Delta P_1 + \frac{\Delta P_2 - \Delta P_1}{\mu_2 - \mu_1} \times (\mu - \mu_1)$$

Note: the mass flow value should be converted to the volume flow value.

The pressure drop of Mass Flow Meter can be checked from following Pressure Drop Chart (including Pressure Drop, flow, and viscosity parameters). Please contact factory for the detail sizing calculation by providing the fluid name, viscosity, density, flow range.

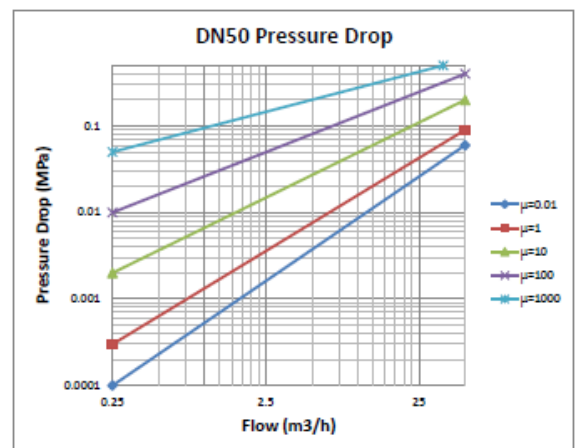
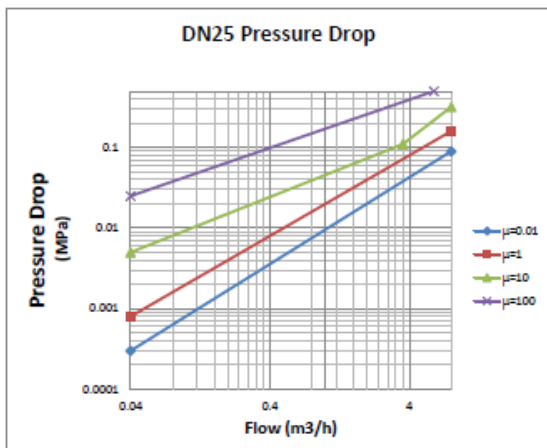
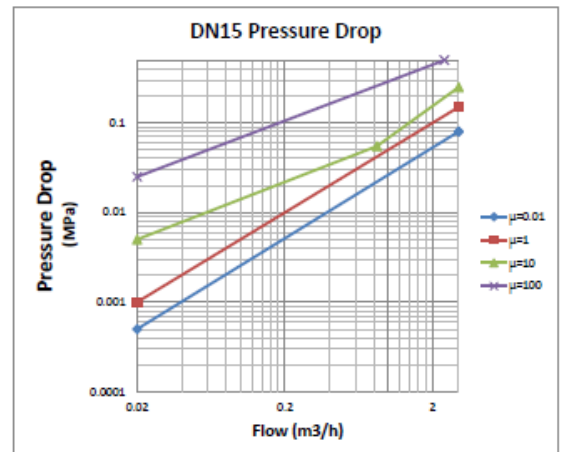
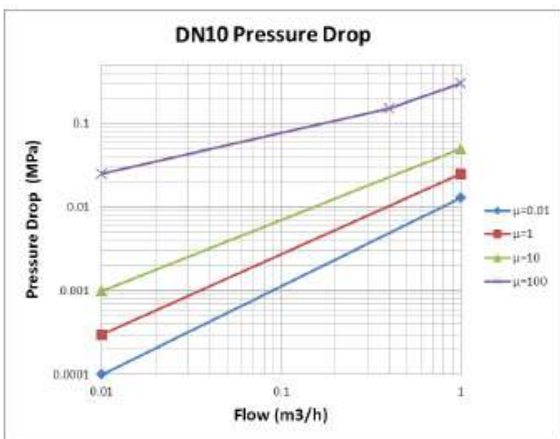

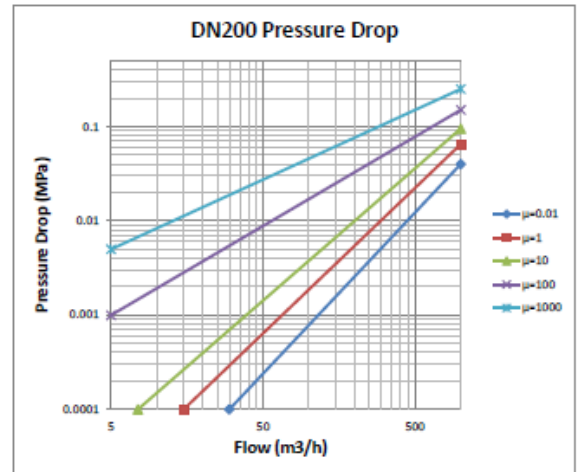
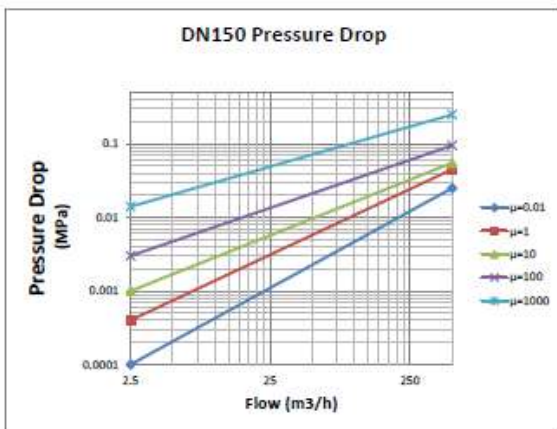
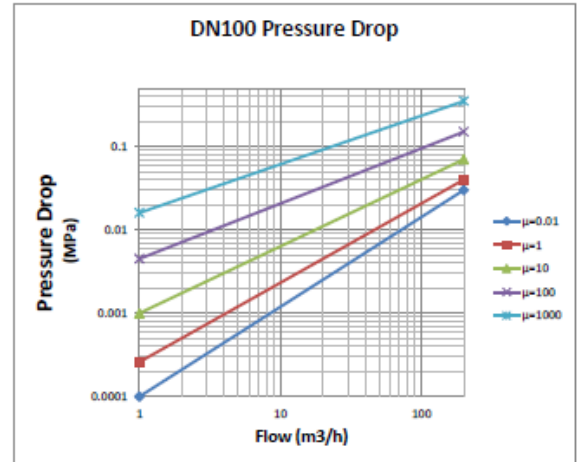
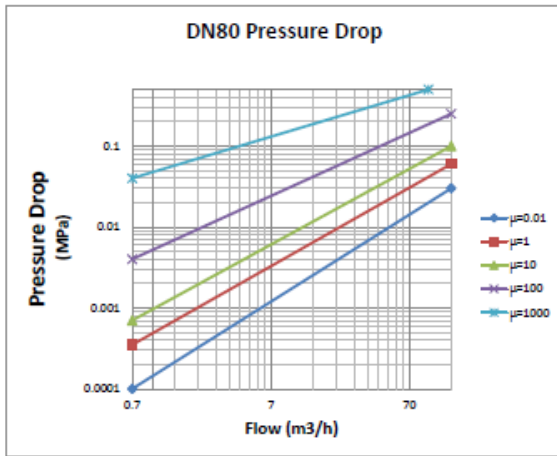

8. Trouble Shooting

8.1 Overview

During the first installation and use, if there is something abnormal related to the working of flowmeter, generally speaking, it should be resulted from either the application or the flowmeter system. Application is usually complex, which involves the measurement error of fluctuation caused by technology, change of medium, so it should be analyzed according to the actual application while this chapter mainly focuses on the causes and solutions of flowmeter system malfunctions.

8.2 Diagnostic Tool

For the flowmeter fault diagnosis, the user can judge by the LED indicator and LCD displays, LED lights of different colors and brightness contrast on the panel, which represent the working condition of flowmeter. Meanwhile, LCD displays can show the self-diagnostic alarming information of the transmitter, which is favorable for user's judgment and defining the malfunctions.

In addition, it is necessary to use handheld digital multimeter when testing the static resistance values and cables of the sensor.

8.3 Sensor

When testing the malfunction of the flowmeter, first of all, detect the coils resistance of sensor according to Table 13 and check if their values are fallen within the normal range.

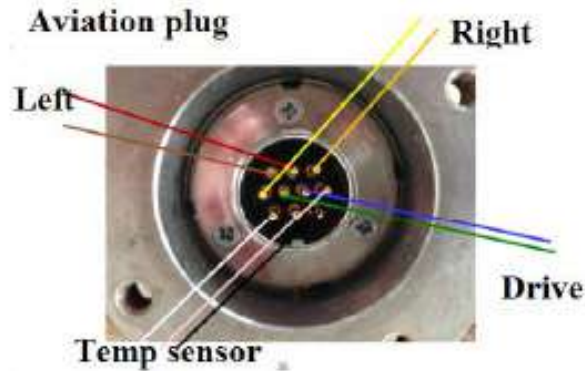

Loop	Wire Color	Sensor port	Normal resistance range
Left coil	Brown, red	1, 2	(20~100) Ω
Right coil	Orange, yellow	3, 4	(20~100) Ω
Drive coil	Blue, green	5, 6	(2~110) Ω
Temperature	Gray, white	7, 8	(75~175) Ω
Temperature	Gray, black	7, 10	(75~175) Ω

8.4 Power and connection

The first installation of electricity, power should be checked to ensure that effective the following elements:

Choose the correct voltage for power supply, connect the power cable correctly, open insulating layer of two ends of the cable and pinch them firmly;

Power cable should be not connected with same output port of Mass Flowmeter Transmitter with signal cables of input/output;

Transmitter should be earthed firmly and the earth resistance should be less than 1 Ω , (use the copper wire with area more than 2.5 mm²).

8.5 LED-Indicator

The proportion of light and dark shown by LED indicator represents the working condition of the flowmeter.

LED condition	Working condition
Always light at beginning	Impassable self-test
Always light afterward	Wrong zero-calibration
Light for 1/4second, dark for 3/4 second	Malfunction alarm
Light for 3/4second, dark for 1/4 second	Slug flow excesses

9. Explosion-proof

» The explosion-proof classification of Mass Flowmeter Series Mass flowmeter is approved by NEPSI as follows:

Mass Flowmeter-Model		Explosion-proof Class
Integrate Type	Mass Flowmeter - 010~200 Flowmeter	Exdib II CT4~T6
Separate Type	Mass Flowmeter - 010~080 Sensor	Exdib II CT3~T6
	Mass Flowmeter-100~200 Sensor	Exdib II CT3~T6
	Mass Flowmeter Transmitter	Exd [ib] II CT6

- » The Mass Flowmeter contains the earth terminal which must be earthed when put into service.
- » Separate type sensor of Mass Flowmeter must be matched with separate type transmitter of Mass Flowmeter and its connection should be adopted with 9-core lines. The 9-core line should be less than 300m and the bending radius of wiring installation should be more than 120mm
- » The user must not change the electric parameters and standard model of explosion-proof parts in the sensor random.
- » It is necessary to disconnect power supply before opening the cover in hazardous application.
- » The cable jacket can be divided into two kinds of $\phi 8.5$ and $\phi 12$ according to the inner hole of cable gasket ring while the outside diameters of cables are respectively $\phi 8 \sim \phi 8.5$ and $\phi 8.5 \sim \phi 12$. Please change the cable and gasket ring once aging or wearing out.
- » Be sure that there is no gases which erode aluminum alloy.
- » Be sure that the maintenance or repair should be in safe place without flammable gases.
- » The correspondences between working temperature of medium and maximum surface temperature of flowmeter body are as follows:

	T3	T4	T5	T6
Working temperature	200°C	135°C	100°C	85°C
Surface temperature	195°C	130°C	95°C	80°C

KLG-MF Digit Mass Flowmeter Program Ver2 .55

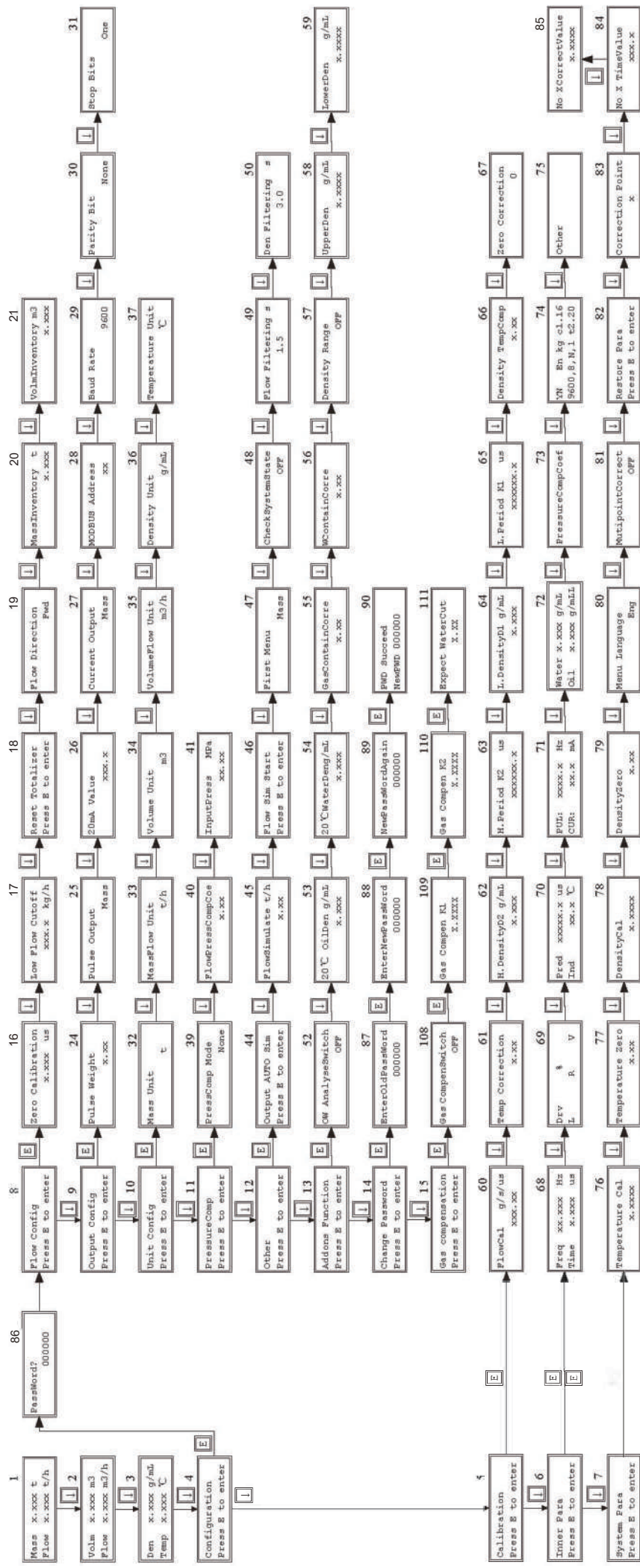

» Note: This menu chart can only be applied to KLG-MF Digit Mass Flowmeter Program Ver2 .55 and later version



KLINGER Portugal, Lda.
Via José Régio, 36
Centro Empresarial Vilar do Pinheiro
4485-860 Vila do Conde
T: +351 229 470 910
E-mail: geral@klinger.pt

www.klinger.pt