

LINED CHECK VALVE

Lined Ball Check | Lined Lift Check | Lined Swing Check
DN15-DN350 | 1/2"-14"

MODEL: KRY

» **Body Material**

ASTM CF8M, CF8, CF3,CF3M, WCB

» **Size Range**

Ball Check:	Lift Check:	Swing Check:
DN: 15 - 150	DN: 15 - 350	DN: 15 - 350
NPS: 1/2" - 6"	NPS: 1/2" - 14"	NPS: 1/2" - 14"

» **Pressure Rating**

PN10*, PN16*,
PN25*, CL150

» **End Connection**

Flanged, Wafer

» **Lining Material**

PFA, FEP, PO

Materials List:

NO	Name	Material		
1	Body, disc, bonnet	A216 WCB+Lining	A351 CF8 / A351 CF8M+Lining	A351 CF3 / A351 CF3M+Lining
2	Ball	PTFE		
3	Lining material	FEP, PFA, PO		
4	Bolt	A193 B7	A320 B8	A193 B8M

Technical Specification:

Design Standard	Manufacturer Std.		Manufacturer
Face-to-face Standard	EN 558 / MFG Std.		ASME B16.10
Flange Standard	EN 1092-1		ASME B16.5
Inspection and Test Standard	See below*		
Nominal Diameter	DN15-DN350		1/2"-14"
Nominal Pressure (MPa)	1.0	1.6	CLASS 150
Pressure Test (MPa)	Shell Test	1.5	1.5
	High Pressure Sealing	1.1	1.1
	Low Pressure Sealing	0.6	0.6
Temperature Range (°C)	PFA: -30~200, FEP:-30~150, PO:-10~80		
Applicable Medium	Strong corrosive medium i.e. hydrochloric acid, Nitric acid, Hydrofluoric acid, Liquid chlorine, Sulfuric Acid and Aqua regia etc.		

*Note: Standards indicated are general standard used as reference, some variations exist. Other standard or tests may be available on request for fee.

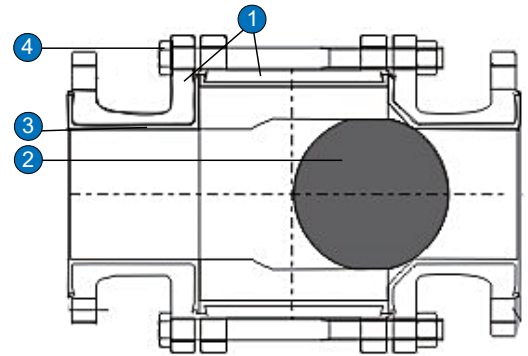

Pressure Temperature Curve

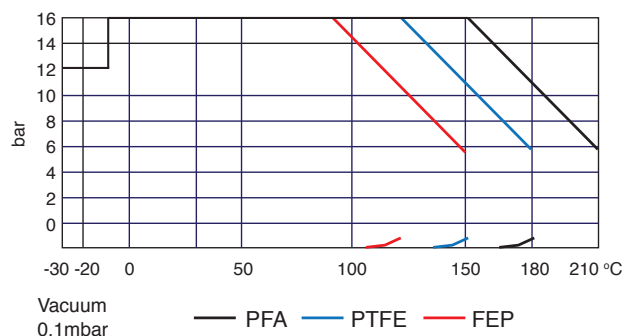

LINED CHECK VALVE

Lined Ball Check Valve

PN10*, DN15-DN150 | PN16*, DN15-DN150

MODEL: KRY-LBC

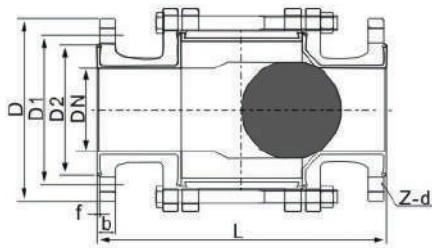

Standard Type (without sight glass)

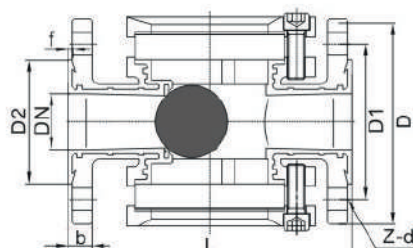

Sight Glass Type

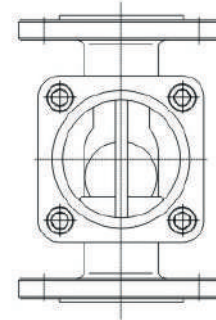

PN10* Dimensions (mm):

DN	L	D	D1	D2	Z-d	f	b
15	130	95	65	45	4-14	2	14
20	150	105	75	55	4-14	2	14
25	160	115	85	65	4-14	2	14
32	180	140	100	78	4-18	3	16
40	200	150	110	85	4-18	3	16
50	230	165	125	100	4-18	3	16
65	290	185	145	120	4-18	3	18
80	310	200	160	135	8-18	3	20
100	350	220	180	155	8-18	3	20
125	400	250	210	185	8-18	3	22
150	480	285	240	210	8-23	3	24

*Note: Some dimensions do not fully conform to EU standards, please be sure to confirm.

PN16* Dimensions (mm):

DN	L	D	D1	D2	Z-d	f	b
15	130	95	65	45	4-14	2	14
20	150	105	75	55	4-14	2	14
25	160	115	85	65	4-14	2	14
32	180	140	100	78	4-18	3	16
40	200	150	110	85	4-18	3	16
50	230	165	125	100	4-18	3	16
65	290	185	145	120	4-18	3	18
80	310	200	160	135	8-18	3	20
100	350	220	180	155	8-18	3	20
125	400	250	210	185	8-18	3	22
150	480	285	240	210	8-23	3	24

*Note: Some dimensions do not fully conform to EU standards, please be sure to confirm.

LINED CHECK VALVE

Lined Ball Check Valve

PN25*, DN15-DN150 | CL150, 1/2"-6"

MODEL: KRY-LBC

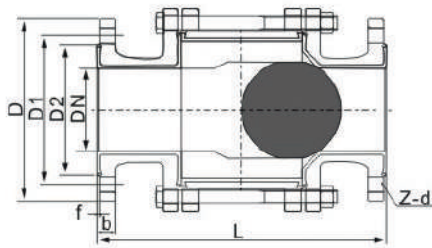

Standard Type (without sight glass)

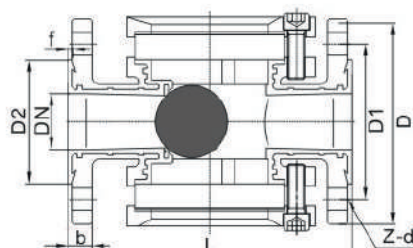

Sight Glass Type

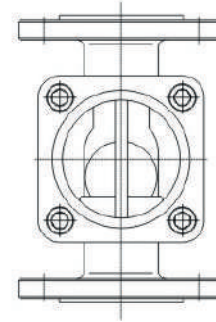

PN25* Dimensions (mm):

DN	L	D	D1	D2	Z-d	f	b
15	130	95	65	45	4-14	2	16
20	150	105	75	55	4-14	2	16
25	160	115	85	65	4-14	2	16
32	180	140	100	78	4-18	3	18
40	200	150	110	85	4-18	3	18
50	230	165	125	100	4-18	3	20
65	290	185	145	120	8-18	3	22
80	310	200	160	135	8-18	3	22
100	350	235	190	160	8-23	3	24
125	400	270	220	188	8-25	3	28
150	480	300	250	218	8-25	3	30

*Note: Some dimensions do not fully conform to EU standards, please be sure to confirm.

CL150 Dimensions (mm):

IN	L	D	D1	D2	Z-d	f	b
1/2"	130	89	60.5	35	4-16	2	12
3/4"	150	98	70.0	43	4-16	2	12
1"	160	108	79.5	51	4-16	2	12
1¼"	180	117	89.0	64	4-16	2	13
1½"	200	127	98.5	73	4-16	2	15
2"	230	152	120.5	92	4-19	2	16
2½"	290	178	139.5	105	4-19	2	18
3"	310	190	152.5	127	4-19	2	19
4"	350	229	190.5	157	8-19	2	24
5"	400	254	216.0	186	8-22	3	24
6"	480	279	241.5	216	8-22	3	26

LINED CHECK VALVE

Lined Lift Check Valve

PN10*, DN15-DN350 | PN16*, DN15-DN350

MODEL: KRY-LLC

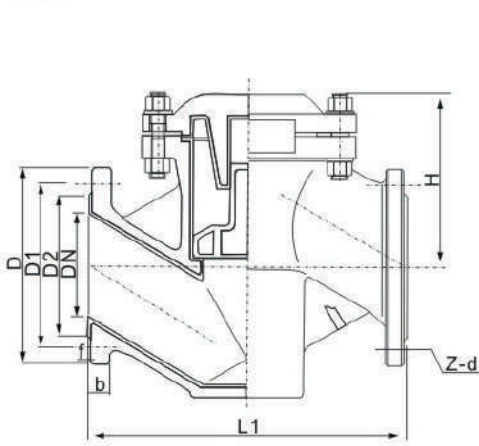

Standard Type

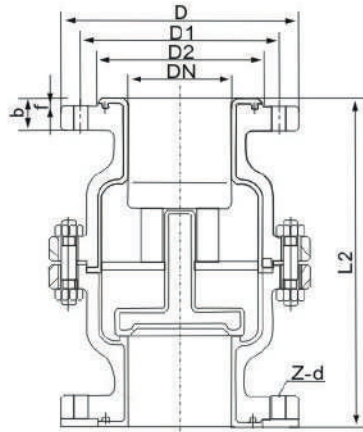

Vertical Type

PN10* Dimensions (mm):

DN	L1	L2	D	D1	D2	Z-d	f	b	H
15	130	80	95	65	45	4-14	2	14	82
20	150	90	105	75	55	4-14	2	14	82
25	160	105	115	85	65	4-14	2	14	98
32	180	110	140	100	78	4-18	3	16	110
40	200	125	150	110	85	4-18	3	16	118
50	230	140	165	125	100	4-18	3	16	138
65	290	160	185	145	120	4-18	3	18	156
80	310	185	200	160	135	8-18	3	20	160
100	350	210	220	180	155	8-18	3	20	185
125	400	250	250	210	185	8-18	3	22	208
150	480	300	285	240	210	8-23	3	24	245
200	600	460	340	295	265	8-23	3	26	298
250	730	520	395	350	320	12-23	4	28	342
300	850	700	445	400	368	12-23	4	28	-
350	980	750	505	460	428	16-23	5	28	-

*Note: Some dimensions do not fully conform to EU standards, please be sure to confirm.

PN16* Dimensions (mm):

DN	L1	L2	D	D1	D2	Z-d	f	b	H
15	130	80	95	65	45	4-14	2	14	82
20	150	90	105	75	55	4-14	2	14	82
25	160	105	115	85	65	4-14	2	14	98
32	180	110	140	100	78	4-18	3	16	110
40	200	125	150	110	85	4-18	3	16	118
50	230	140	165	125	100	4-18	3	16	138
65	290	160	185	145	120	4-18	3	18	156
80	310	185	200	160	135	8-18	3	20	160
100	350	210	220	180	155	8-18	3	20	185
125	400	250	250	210	185	8-18	3	22	208
150	480	300	285	240	210	8-23	3	24	245
200	600	460	340	295	265	12-23	3	26	298
250	730	520	405	355	320	12-25	4	28	342
300	850	700	460	410	375	12-25	4	29	-
350	980	750	520	470	435	16-25	5	34	-

*Note: Some dimensions do not fully conform to EU standards, please be sure to confirm.

LINED CHECK VALVE

Lined Lift Check Valve

PN25*, DN15-DN350 | CL150, 1/2"-14"

MODEL: KRY-LLC

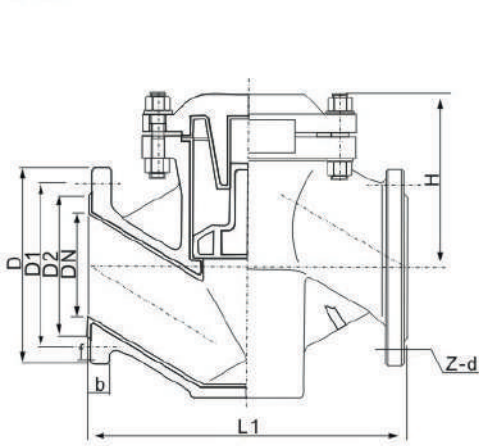

Standard Type

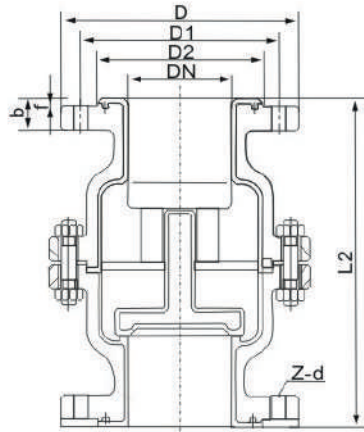

Vertical Type

PN25* Dimensions (mm):

DN	L1	L2	D	D1	D2	Z-d	f	b	H
15	130	80	95	65	45	4-14	2	16	82
20	150	90	105	75	55	4-14	2	16	82
25	160	105	115	85	65	4-14	2	16	98
32	180	110	140	100	78	4-18	3	18	110
40	200	125	150	110	85	4-18	3	18	118
50	230	140	165	125	100	4-18	3	20	138
65	290	160	185	145	120	8-18	3	22	156
80	310	185	200	160	135	8-18	3	22	160
100	350	210	235	190	160	8-23	3	24	185
125	400	250	270	220	188	8-25	3	28	208
150	480	300	300	250	218	8-25	3	30	245
200	600	460	360	310	278	12-25	3	34	298
250	730	520	425	370	332	12-30	4	36	342
300	850	700	485	410	375	16-30	4	39	-
350	980	750	550	490	448	16-34	5	44	-

*Note: Some dimensions do not fully conform to EU standards, please be sure to confirm.

CL150 Dimensions (mm):

IN	L1	L2	D	D1	D2	Z-d	f	b	H
1/2"	130	80	89	60.5	35	4-16	2	12	82
3/4"	150	90	98	70.0	43	4-16	2	12	82
1"	160	105	108	79.5	51	4-16	2	12	98
1¼"	180	110	117	89.0	64	4-16	2	13	110
1½"	200	125	127	98.5	73	4-16	2	15	118
2"	230	140	152	120.5	92	4-19	2	16	138
2½"	290	160	178	139.5	105	4-19	2	18	156
3"	310	185	190	152.5	127	4-19	2	19	160
4"	350	210	229	190.5	157	8-19	2	24	185
5"	400	250	254	216.0	186	8-22	3	24	208
6"	480	300	279	241.5	216	8-22	3	26	245
8"	600	460	343	298.5	270	8-22	3	29	298
10"	730	520	406	362.0	324	12-25	3	31	342
12"	850	700	485	432	381	12-25	4	34.7	-
14"	980	750	535	476	412.7	12-29	5	39	-

LINED CHECK VALVE

Lined Swing Check Valve, Wafer/Flanged
 PN10*, DN15-DN350 | PN16*, DN15-DN350

MODEL: KRY-LSC

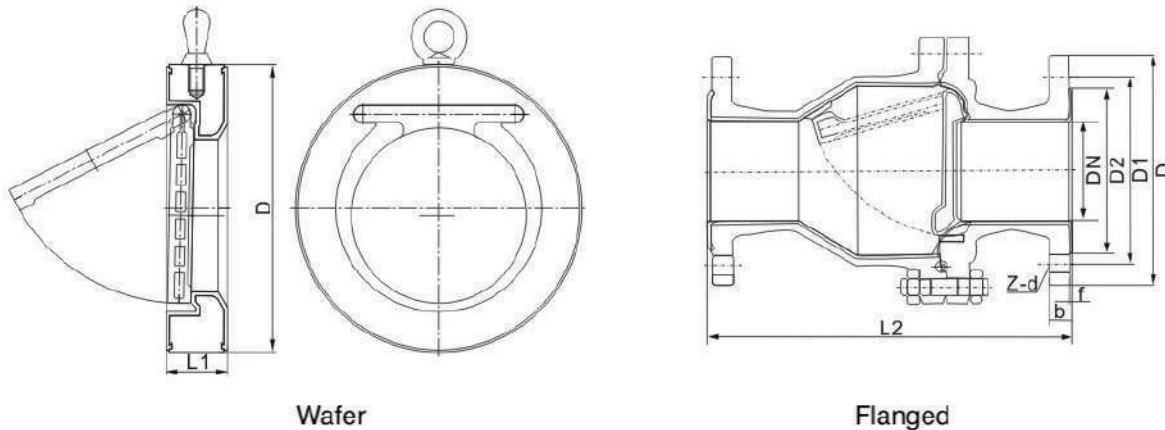

PN10* Dimensions (mm):

DN	L1	L2	D	D1	D2	Z-d	f	b
15	/	130	95	65	45	4-14	2	14
20	/	150	105	75	55	4-14	2	14
25	/	160	115	85	65	4-14	2	14
32	/	180	140	100	78	4-18	3	16
40	/	200	150	110	85	4-18	3	16
50	43	230	165	125	100	4-18	3	16
65	46	290	185	145	120	4-18	3	18
80	46	310	200	160	135	4-18	3	20
100	52	350	220	180	155	8-18	3	20
125	56	400	250	210	185	8-18	3	22
150	56	480	285	240	210	8-23	3	24
200	60	495	340	295	265	8-23	3	26
250	68	550	395	350	320	12-23	4	28
300	78	620	445	400	368	12-23	4	28
350	78	720	505	460	428	16-23	5	28

*Note: Some dimensions do not fully conform to EU standards, please be sure to confirm.

PN16* Dimensions (mm):

DN	L1	L2	D	D1	D2	Z-d	f	b
15	/	130	95	65	45	4-14	2	14
20	/	150	105	75	55	4-14	2	14
25	/	160	115	85	65	4-14	2	14
32	/	180	140	100	78	4-18	3	16
40	/	200	150	110	85	4-18	3	16
50	43	230	165	125	100	4-18	3	16
65	46	290	185	145	120	4-18	3	18
80	46	310	200	160	135	8-18	3	20
100	52	350	220	180	155	8-18	3	20
125	56	400	250	210	185	8-18	3	22
150	56	480	285	240	210	8-23	3	24
200	60	495	340	295	265	12-23	3	26
250	68	550	405	355	320	12-25	4	28
300	78	620	460	410	375	12-25	4	29
350	78	720	520	470	435	16-25	5	34

*Note: Some dimensions do not fully conform to EU standards, please be sure to confirm.

LINED CHECK VALVE

Lined Swing Check Valve, Wafer/Flanged
 PN25*, DN15-DN350 | CL150, 1/2"-14"

MODEL: KRY-LSC

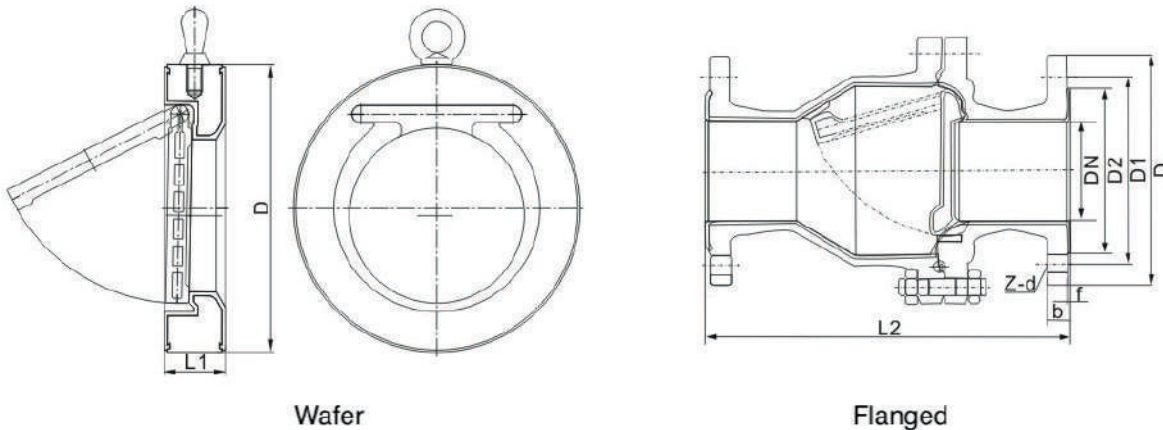

PN25* Dimensions (mm):

DN	L1	L2	D	D1	D2	Z-d	f	b
15	/	130	95	65	45	4-14	2	16
20	/	150	105	75	55	4-14	2	16
25	/	160	115	85	65	4-14	2	16
32	/	180	140	100	78	4-18	3	18
40	/	200	150	110	85	4-18	3	18
50	43	230	165	125	100	4-18	3	20
65	46	290	185	145	120	8-18	3	22
80	46	310	200	160	135	8-18	3	22
100	52	350	230	190	160	8-23	3	24
125	56	400	270	220	188	8-25	3	28
150	56	480	300	250	218	8-25	3	30
200	60	495	360	310	278	12-25	3	34
250	68	550	425	370	332	12-30	4	36
300	78	620	485	410	375	16-30	4	39
350	78	720	550	490	448	16-34	5	44

*Note: Some dimensions do not fully conform to EU standards, please be sure to confirm.

CL150 Dimensions (mm):

IN	L1	L2	D	D1	D2	Z-d	f	b
1/2"	/	130	89	60.5	35	4-16	2	12
3/4"	/	150	98	70.0	43	4-16	2	12
1"	/	160	108	79.5	51	4-16	2	12
1¼"	/	180	117	89.0	64	4-16	2	13
1½"	/	200	127	98.5	73	4-16	2	15
2"	43	230	152	120.5	92	4-19	2	16
2½"	46	290	178	139.5	105	4-19	2	18
3"	46	310	190	152.5	127	4-19	2	19
4"	52	350	229	190.5	157	8-19	2	24
5"	56	400	254	216.0	186	8-22	3	24
6"	56	480	279	241.5	216	8-22	3	26
8"	60	495	343	298.5	270	8-22	3	29
10"	68	550	406	362.0	324	12-25	3	31
12"	78	620	482.6	431.8	381	12-25	4	34.7
14"	78	720	533.4	476.2	412.7	12-29	5	39

LINED VALVE

Fluorine Plastic Performance

Performance	Item		PTFE	PVDF	FEP	PFA	PO	PE	PP
			F4	F2	F46	PFA	PO	PE	PP
Physical Performance	Specific Gravity	g/cm3	2.1-2.2	1.76	2.1-2.2	2.1-2.2	0.92	0.92	0.92
	Water absorption	%	0.001~0.005	0.04	≤0.01	≤0.01	0.005	0.005	0.005
	Shrinkage rate of finished product	%	1~5	2.0	2~5	1~5	1~2	1~2	1~2
	Embrittlement coefficient	10-5/K	10~12	8.5~15.3	8.3~10.5	8.3~12	-	-	-
	Embrittlement temperature T1	°C	-180~-195	-62	-260	-180~-195	-40	-40	-20
	Hot resistance T2	°C	260	150	204	260	100	100	100
	Recommend working temperature T3	°C	≤180	≤100	≤150	≤200	≤85	≤85	≤85
Mechanical Performance	Hardness	SOSIXO	D50-65	D80	(R45)	D50-65	D40	D40	D40
	Friction coefficient f	-	0.06	0.14-0.17	0.06-0.11	0.06-0.11	-	-	-
	Tensile strength σ_b	MPa	13.7-24.5	45-48.3	20.0-24.5	14-28	≥10	6.9-14	7.5-14
	Bending strength σ_w	MPa	10.7-13.7	-	-	15-28	-	-	-
	Compression strength σ_y	MPa	111	68.6	-	111	-	-	-
	Impact strength σ_k	KJ/m2	16	19.7	Continuous	1 +	-55	45	50
	Ultimate elongation $\Delta\lambda$	%	250-350	30-300	250-270	300-500	480	300-600	600-700
	Breakdown voltage v	KV/mm	25~40	10.2	40	25~40	-	-	-
Processing Performance	Compression molding		Good	Good	Good	Good	Good	Good	Good
	Injection molding		-	Good	Good	Good	Good	Good	Good
	Lamination		Good	Good	Good	Good	Good	Good	Good
	Lamination		Good	Good	Good	Good	Good	Good	Good

LINED VALVE

Fluorine Plastic Performance

Corrosion Resistance performance (theoretical reference)

Medium	Concentration (%)	Temperature (°C)	PTFE	PVDF	FEP	PFA	PO	PE	PP
Sulfuric acid	10~98	Normal temperature ~100	A	A~B	A	A	Concentration ≤50%	Concentration ≤60%	A
Nitric acid	5~98	Normal temperature ~100	A	A	A	A	Concentration ≤30%	Concentration ≤60%	A
Hydrochloric acid	10~38	Normal temperature ~100	A	A	A	A	Concentration ≤38%	Concentration ≤60%	A~B
Acetic acid	10~100	Normal temperature ~100	A	A~B	A	A	Concentration ≤10%	Concentration ≤60%	A
Chromic acid	50~100	Normal temperature ~70	A	A~B	A	A	Concentration ≤30%	Concentration ≤20%	A
Phosphoric acid	50~85	Normal tempera- ture~100	A~B	D	A~B	A~B	Concentration ≤85%	Concentration ≤80%	A
Trichloroethane	100	Normal temperature	C	B	C	C	X	X	X
Copper-sulfate	15	Normal temperature	A	C	A	A	Concentration ≤90%	Concentration ≤80%	A
Diethyl ether	100	Normal temperature	B	C	B	B	X	X	X
Ethyl acetate	100	Normal temperature	B	A	B	B	X	X	X
Petrol	100	Normal temperature	A	A~B	A	A	X	X	X
Hydrogen peroxide	3~30	Normal temperature	A	A	A	A	Concentration ≤30%	Concentration ≤60%	A
Nitrobenzene	100	Normal temperature	A	A~B	A	A	X	X	X
Superalkali	10-50	Normal tempera- ture~100	A	A	A	A	Concentration ≤80%	Concentration ≤60%	A
Sodium Hypochlorite	-	70	A	B	A	A	Concentration ≤80%	Concentration ≤60%	A~B
Hydroxyl acid	40~99	-10~30	A~B	B	A~B	A~B	Concentration ≤80%	Concentration ≤60%	A~B
Oleum	20	Normal temperature	A	B	A	A	X	X	X
Acrylonitrile	-	Normal temperature	B	C	B	B	-	-	-
Aniline	100	Normal temperature	B	B	B	B	Concentration ≤60%	Concentration ≤20%	B
Benzene	100	Normal temperature	B	C	B	B	X	X	X
Butyl acetate	100	Normal temperature	B	C	B	B	Concentration ≤60%	Concentration ≤20%	B
Tetrachloromethane	Reagent grade	Normal temperature	B	C	B	B	X	X	X

Data indicated are theoretical value for reference. Depending on valve type and DN size, temperature limitation may be reduced accordingly.

A = Excellent, B = Good, C = OK, D = Poor

Many factors influence corrosion rating such as temperature fluctuation, concentration and aeration of fluids, high velocity or abrasions in the fluid steam, etc. The physical properties of material are affected differently by each corrosive media and sometimes it is inevitable one property is sacrificed for gain in another property. The corrosion data is provided as a comprehensive theoretical guide indicating the possible range, user must consider all parameters and exercise sound engineering judgment in material selection.