

# LINED PLUG VALVE

Lined 2-way & 3-way Plug Valve  
DN15~DN250 | 1/2"~10"

**MODEL: KPY-LPV**

- » **Body Material**  
ASTM CF8M, CF8, WCB
- » **Size Range**  
DN: 15 - 250  
NPS: 1/2" - 10"
- » **Pressure Rating**  
PN10\*, PN16\*  
CL150, CL300
- » **End Connection**  
Flanged
- » **Lining Material**  
PFA, FEP, PO

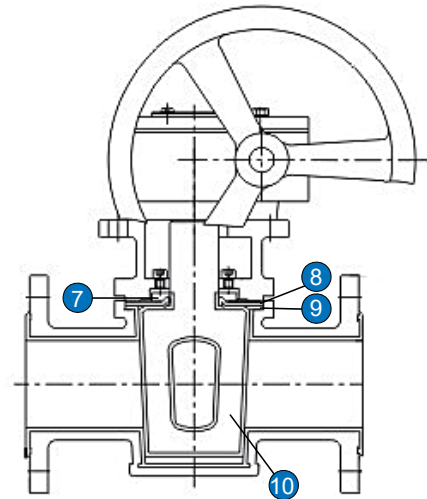

## Materials List:

NO	Name	Material		
1	Body blot	A193 B7	A320 B8	A193 B8M
2	Handle seat	A216 WCB	A351 CF8	A351 CF8M
3	Operation rod	1025 SS304		
4	Top cap bolt	A193 B7	A320 B8	A193 B8
5	Adjusting screw	A193 B7	A320 B8	A193 B8M
6	Bonnet	A216 WCB	A351 CF8	A351 CF8M
7	Metal gasket	SS304		
8	V-shape gasket	PTFE		
9	Wedge ring	PTFE		
10	Plug	A216WCB +Lining	A351 CF8+Lining	A351 CF8M +Lining
11	Body	A216 WCB +Lining	A351 CF8+Lining	A351 CF8M +Lining

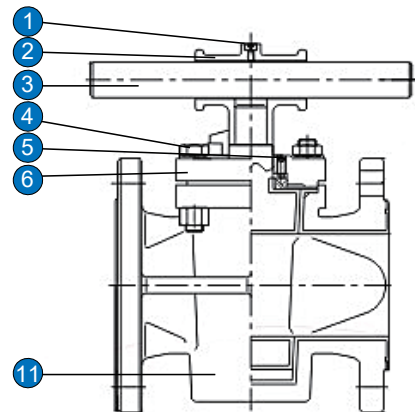

## Technical Specification:

<b>Design &amp; Manufacture Standard</b>	Manufacturer Std.	API 6D	
<b>Face-to-face Dimension Standard</b>	EN 558 Series 1/3	ASMEB16.10	
<b>Flange Standard</b>	EN 1092-1	ASMEB16.5	
<b>Inspection and Test Standard</b>	See below*		
<b>Nominal Diameter</b>	DN15-DN250	1/2"-10"	
<b>Nominal Pressure (MPa)</b>	1.0	1.6	CLASS 150
<b>Hressure Test (MPa)</b>	<b>Shell Test</b>	1.5	1.5
	<b>High Pressure Sealing</b>	1.1	1.1
	<b>Low Pressure Sealing</b>	0.6	0.6
<b>Temperature Range (°C)</b>	PFA: -30~200, FEP:-30~150		
<b>Applicable Medium</b>	Strong corrosive medium i.e. hydrochloric acid, Nitric acid, Hydrofluoric acid, Liquid chlorine, Sulfuric Acid and Aqua regia etc.		

\*Note: Standards indicated are general standard used as reference, some variations exist. Other standard or tests may be available on request for fee.

# LINED PLUG VALVE

Lined 2-way Plug Valve  
 PN10\*, DN15-DN250 | PN16\*, DN15-DN250

**MODEL: KPY-LPV**

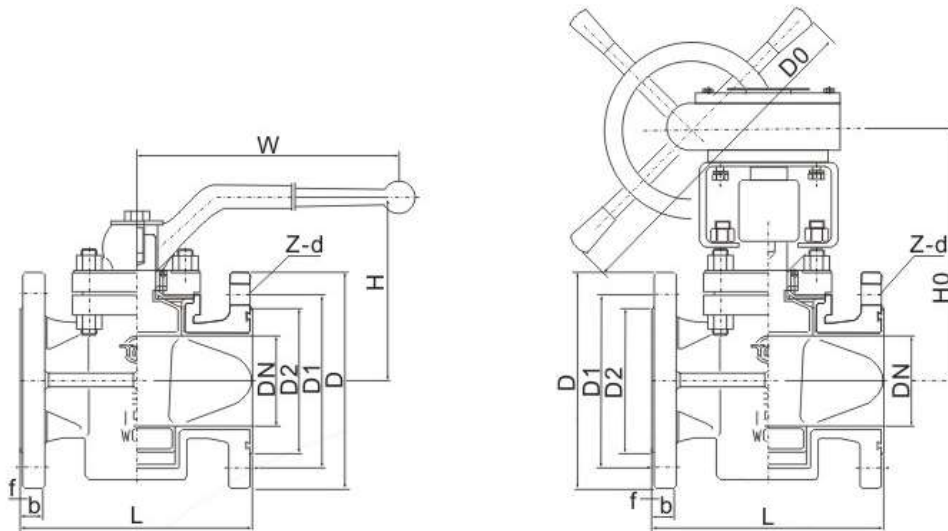

## PN10\* Dimensions (mm):

DN	L	D	D1	D2	Z-d	f	b	H	W	H0
15	110	95	65	45	4-14	2	14	85	180	-
20	117	105	75	55	4-14	2	14	88	180	-
25	127	115	85	65	4-14	2	14	98	260	-
32	140	140	100	78	4-18	3	16	101	260	-
40	165	150	110	85	4-18	3	16	128	320	-
50	178	165	125	100	4-18	3	16	128	320	-
65	190	185	145	120	4-18	3	18	135	320	-
80	203	200	160	135	8-18	3	20	164	400	322
100	229	220	180	155	8-18	3	20	178	400	332
125	254	250	210	185	8-18	3	22	205	-	385
150	267	285	240	210	8-23	3	24	220	-	405
200	292	340	295	265	8-23	3	26	-	-	455
250	330	395	350	320	12-23	4	28	-	-	490

\*Note: Some dimensions do not fully conform to EU standards, please be sure to confirm.

## PN16\* Dimensions (mm):

DN	L	D	D1	D2	Z-d	f	b	H	W	H0
15	110	95	65	45	4-14	2	14	85	180	-
20	117	105	75	55	4-14	2	14	88	180	-
25	127	115	85	65	4-14	2	14	98	260	-
32	140	140	100	78	4-18	3	16	101	260	-
40	165	150	110	85	4-18	3	16	128	320	-
50	178	165	125	100	4-18	3	16	128	320	-
65	190	185	145	120	4-18	3	18	135	320	-
80	203	200	160	135	8-18	3	20	164	400	322
100	229	220	180	155	8-18	3	20	178	400	332
125	254	250	210	185	8-18	3	22	205	-	385
150	267	285	240	210	8-23	3	24	220	-	405
200	292	340	295	265	12-23	3	26	-	-	455
250	330	405	355	320	12-26	4	28	-	-	490

\*Note: Some dimensions do not fully conform to EU standards, please be sure to confirm

# LINED PLUG VALVE

Lined 3-way Plug Valve  
 PN10\*, DN25-DN150 | PN16\*, DN25-DN150

**MODEL: KPY-LPV3W**

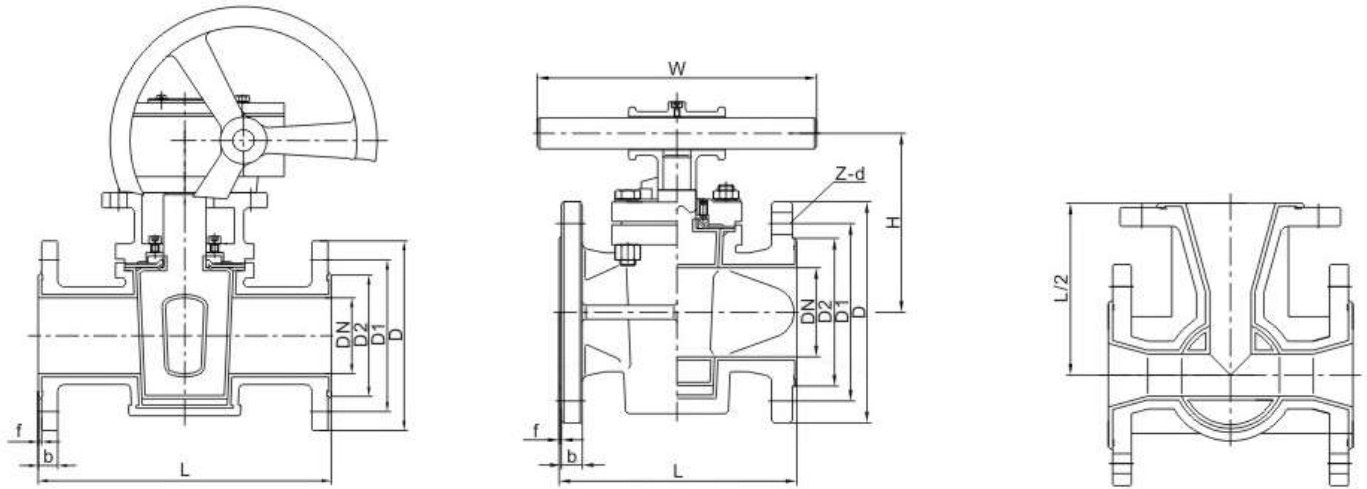

## PN10\* Dimensions (mm):

DN	L	D	D1	D2	Z-d	f	b	H	W	H0
25	160	115	85	65	4-14	2	14	98	260	-
32	180	140	100	78	4-18	3	16	101	260	-
40	200	150	110	85	4-18	3	16	128	320	-
50	230	165	125	100	4-18	3	16	128	320	-
65	290	185	145	120	4-18	3	18	135	320	-
80	310	200	160	135	8-18	3	20	164	400	322
100	350	220	180	155	8-18	3	20	178	400	332
125	400	250	210	185	8-18	3	22	205	-	385
150	480	285	240	210	8-23	3	24	220	-	405

\*Note: Some dimensions do not fully conform to EU standards, please be sure to confirm.

## PN16\* Dimensions (mm):

DN	L	D	D1	D2	Z-d	f	b	H	W	H0
25	160	115	85	65	4-14	2	14	98	260	-
32	180	140	100	78	4-18	3	16	101	260	-
40	200	150	110	85	4-18	3	16	128	320	-
50	230	165	125	100	4-18	3	16	128	320	-
65	290	185	145	120	4-18	3	18	135	320	-
80	310	200	160	135	8-18	3	20	164	400	322
100	350	220	180	155	8-18	3	20	178	400	332
125	400	250	210	185	8-18	3	22	205	-	385
150	480	285	240	210	8-23	3	24	220	-	405

\*Note: Some dimensions do not fully conform to EU standards, please be sure to confirm.

# LINED PLUG VALVE

Lined 3-way Plug Valve  
CL150, 1/2"~10" | CL300, 1/2"~10"

**MODEL: KPY-LPV3W**

## TECHNICAL DRAWINGS

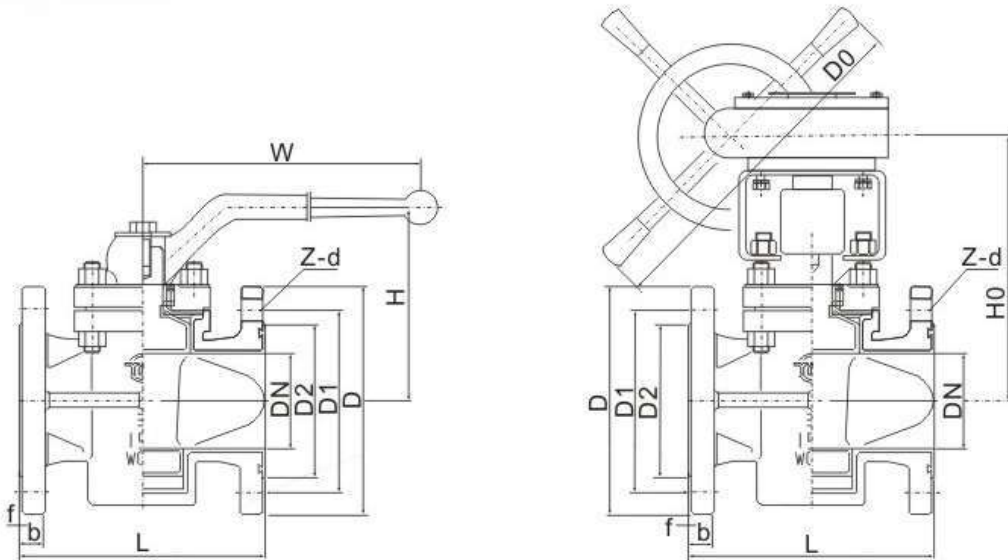

### CL150 Dimensions (mm):

IN	DN	L	D	D1	D2	Z-d	f	b	H	w	H0
1/2"	15	110	89	60.5	35	4-16	2	11	85	180	-
3/4"	20	117	98	70.0	43	4-16	2	13	88	180	-
1"	25	127	108	79.5	51	4-16	2	14	98	260	-
1 1/4"	32	140	117	89.0	64	4-16	2	15.7	101	260	-
1 1/2"	40	165	127	98.5	73	4-16	2	17.5	128	320	-
2"	50	178	152	120.5	92	4-19	2	19	128	320	-
2 1/2"	65	190	178	139.5	105	4-19	2	22	135	320	-
3"	80	203	190	152.5	127	4-19	2	24	164	400	322
4"	100	229	229	190.5	157	8-19	2	24	178	400	332
5"	125	254	254	216.0	186	8-22	3	24	205	-	385
6"	150	267	279	241.5	216	8-22	3	25.4	220	-	405
8"	200	292	343	298.5	270	8-22	3	28.5	-	-	455
10"	250	330	406	362.0	324	12-25	3	30	-	-	490

### CL300 Dimensions (mm):

IN	DN	L	D	D1	D2	Z-d	f	b	H	w	H0
1/2"	15	140	95	66.5	35	4-16	2	14	85	180	-
3/4"	20	152	117	82.5	43	4-19	2	15.7	88	180	-
1"	25	165	124	89.0	51	4-19	2	17.5	98	260	-
1 1/4"	32	178	133	98.5	64	4-19	2	19	101	260	-
1 1/2"	40	190	156	114.5	73	4-22	2	20.5	128	320	-
2"	50	216	165	127.0	92	8-19	2	22.4	128	320	-
2 1/2"	65	241	190	149.0	105	8-22	2	25.4	135	320	-
3"	80	283	210	168.5	127	8-22	2	28.4	164	400	322
4"	100	305	254	200.0	157	8-22	2	32	178	400	332
5"	125	381	279	235.0	186	8-22	3	35	205	-	385
6"	150	403	318	270.0	216	12-22	3	36.6	220	-	405
8"	200	419	381	330.0	270	12-25	3	41	-	-	455
10"	250	457	445	387.5	324	16-29	3	47.8	-	-	490

# LINED VALVE

## Fluorine Plastic Performance

Performance	Item		PTFE	PVDF	FEP	PFA	PO	PE	PP
			F4	F2	F46	PFA	PO	PE	PP
Physical Performance	Specific Gravity	g/cm <sup>3</sup>	2.1-2.2	1.76	2.1-2.2	2.1-2.2	0.92	0.92	0.92
	Water absorption	%	0.001~0.005	0.04	≤0.01	≤0.01	0.005	0.005	0.005
	Shrinkage rate of finished product	%	1~5	2.0	2~5	1~5	1~2	1~2	1~2
	Embrittlement coefficient	10-5/K	10~12	8.5~15.3	8.3~10.5	8.3~12	-	-	-
	Embrittlement temperature T1	°C	-180~-195	-62	-260	-180~-195	-40	-40	-20
	Hot resistance T2	°C	260	150	204	260	100	100	100
	Recommend working temperature T3	°C	≤180	≤100	≤150	≤200	≤85	≤85	≤85
Mechanical Performance	Hardness	SOSIXO	D50-65	D80	(R45)	D50-65	D40	D40	D40
	Friction coefficient f	-	0.06	0.14-0.17	0.06-0.11	0.06-0.11	-	-	-
	Tensile strength $\sigma_b$	MPa	13.7-24.5	45-48.3	20.0-24.5	14-28	≥10	6.9-14	7.5-14
	Bending strength $\sigma_w$	MPa	10.7-13.7	-	-	15-28	-	-	-
	Compression strength $\sigma_y$	MPa	111	68.6	-	111	-	-	-
	Impact strength $\sigma_k$	KJ/m <sup>2</sup>	16	19.7	Continuous	1 +	-55	45	50
	Ultimate elongation $\Delta\lambda$	%	250-350	30-300	250-270	300-500	480	300-600	600-700
	Breakdown voltage v	KV/mm	25~40	10.2	40	25~40	-	-	-
Processing Performance	Compression molding		Good	Good	Good	Good	Good	Good	Good
	Injection molding		-	Good	Good	Good	Good	Good	Good
	Lamination		Good	Good	Good	Good	Good	Good	Good
	Lamination		Good	Good	Good	Good	Good	Good	Good

# LINED VALVE

## Fluorine Plastic Performance

### Corrosion Resistance performance (theoretical reference)

Medium	Concentration (%)	Temperature (°C)	PTFE	PVDF	FEP	PFA	PO	PE	PP
Sulfuric acid	10~98	Normal temperature -100	A	A~B	A	A	Concentration ≤50%	Concentration ≤60%	A
Nitric acid	5~98	Normal temperature ~100	A	A	A	A	Concentration ≤30%	Concentration ≤60%	A
Hydrochloric acid	10~38	Normal temperature ~100	A	A	A	A	Concentration ≤38%	Concentration ≤60%	A~B
Acetic acid	10~100	Normal temperature ~100	A	A~B	A	A	Concentration ≤10%	Concentration ≤60%	A
Chromic acid	50~100	Normal temperature ~70	A	A~B	A	A	Concentration ≤30%	Concentration ≤20%	A
Phosphoric acid	50~85	Normal tempera- ture~100	A~B	D	A~B	A~B	Concentration ≤85%	Concentration ≤80%	A
Trichloroethane	100	Normal temperature	C	B	C	C	X	X	X
Copper-sulfate	15	Normal temperature	A	C	A	A	Concentration ≤90%	Concentration ≤80%	A
Diethyl ether	100	Normal temperature	B	C	B	B	X	X	X
Ethyl acetate	100	Normal temperature	B	A	B	B	X	X	X
Petrol	100	Normal temperature	A	A~B	A	A	X	X	X
Hydrogen peroxide	3~30	Normal temperature	A	A	A	A	Concentration ≤30%	Concentration ≤60%	A
Nitrobenzene	100	Normal temperature	A	A~B	A	A	X	X	X
Superalkali	10-50	Normal tempera- ture~100	A	A	A	A	Concentration ≤80%	Concentration ≤60%	A
Sodium Hypochlorite	-	70	A	B	A	A	Concentration ≤80%	Concentration ≤60%	A~B
Hydroxyl acid	40~99	-10~30	A~B	B	A~B	A~B	Concentration ≤80%	Concentration ≤60%	A~B
Oleum	20	Normal temperature	A	B	A	A	X	X	X
Acrylonitrile	-	Normal temperature	B	C	B	B	-	-	-
Aniline	100	Normal temperature	B	B	B	B	Concentration ≤60%	Concentration ≤20%	B
Benzene	100	Normal temperature	B	C	B	B	X	X	X
Butyl acetate	100	Normal temperature	B	C	B	B	Concentration ≤60%	Concentration ≤20%	B
Tetrachloromethane	Reagent grade	Normal temperature	B	C	B	B	X	X	X

Data indicated are theoretical value for reference. Depending on valve type and DN size, temperature limitation may be reduced accordingly.

A = Excellent, B = Good, C = OK, D = Poor

Many factors influence corrosion rating such as temperature fluctuation, concentration and aeration of fluids, high velocity or abrasions in the fluid steam, etc. The physical properties of material are affected differently by each corrosive media and sometimes it is inevitable one property is sacrificed for gain in another property. The corrosion data is provided as a comprehensive theoretical guide indicating the possible range, user must consider all parameters and exercise sound engineering judgment in material selection.