

LINED BALL VALVE

2-Piece Lined Flanged Ball Valve
DN15-DN350 | 1/2"-14"

MODEL: KHY-LB

- » **Body Material**
ASTM CF8M, CF8, CF3, CF3M, WCB
- » **Size Range**
DN: 15 - 350
NPS: 1/2" - 14"
- » **Pressure Rating**
PN6*, PN10*, PN16*, PN25*,
CL150, JIS10K
- » **End Connection**
Flanged
- » **Lining Material**
PFA, FEP, PO

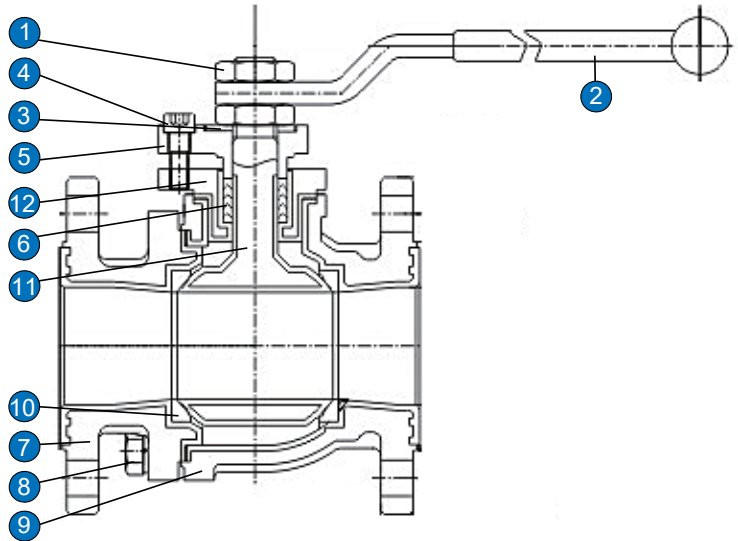

Materials List:

NO	Name	Material		
1	Nut	A194 2H	A194 8	A194 8M
2	Lever	A216 WCB	A351 CF8 / A351 CF8M	A351 CF3 / A351 CF3M
3	Locating Plate	25#, SS304		
4	Gland bolt	A193 B7	A320 B8	A193 B8M
5	Gland	A216 WCB	A351 CF8 / A351 CF8M	A351 CF3 / A351 CF3M
6	Packing	PTFE		
7	Cap	A216 WCB +Lining	A351 CF8 CF8M+Lining	A351 CF3 CF3M+Lining
8	Body bolt	A193 B7	A320 B8	A193 B8M
9	Body	A216 WCB +Lining	A351 CF8 CF8M+Lining	A351 CF3 CF3M+Lining
10	Seat	PTFE, RPTFE, PEEK		
11	Ball/stem	A216 WCB +Lining	A351 CF8 CF8M+Lining	A351 CF3 CF3M+Lining
12	Bonnet	A216 WCB +Lining	A351 CF8 CF8M+Lining	A351 CF3 CF3M+Lining

Pressure Temperature Curve

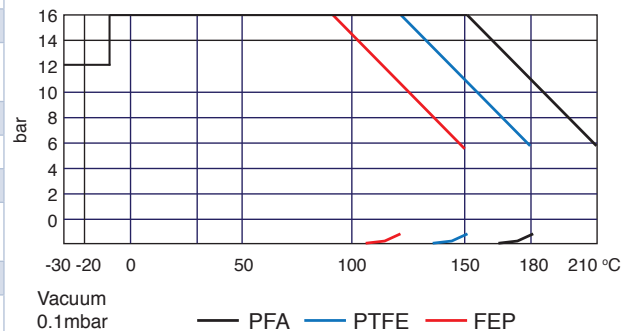

Flow Characteristic

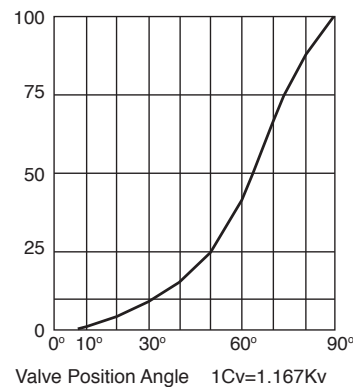

Technical Specification:

Design Standard	Manufacturer Std.	Manufacturer Std.	
Face-to-face Standard	Manufacturer Std.	ASME B16.10	
Flange Standard	EN 1092-1	ASME B16.5, JIS B2220	
Inspection and Test Standard	See below*		
Nominal Diameter	DN15-DN350	1/2"-14"	
Nominal Pressure (MPa)	1.0	1.6	CLASS 150
Pressure Test (MPa)	Shell Test	1.5	1.5
	High Pressure Sealing	1.1	1.1
	Low Pressure Sealing	0.6	0.6
Temperature Range (°C)	PFA: -30~200, FEP:-30~150, PO:-10~80		
Applicable Medium	Strong corrosive medium i.e. hydrochloric acid, nitric acid, hydrofluoric acid, liquid chlorine, Sulfuric acid and aqua regia etc.		

*Note: Standards indicated are general standard used as reference, some variations exist. Other standard or tests may be available on request for fee.

KLINGER Portugal, Ltd.

Tel +351 229 470 910 | www.klinger.pt | geral@klinger.pt

trusted. worldwide.

LINED BALL VALVE

2-Piece Lined Flanged Ball Valve

CL150, 1/2"-10" | JIS10K, DN15-DN250

MODEL: KHY-LB

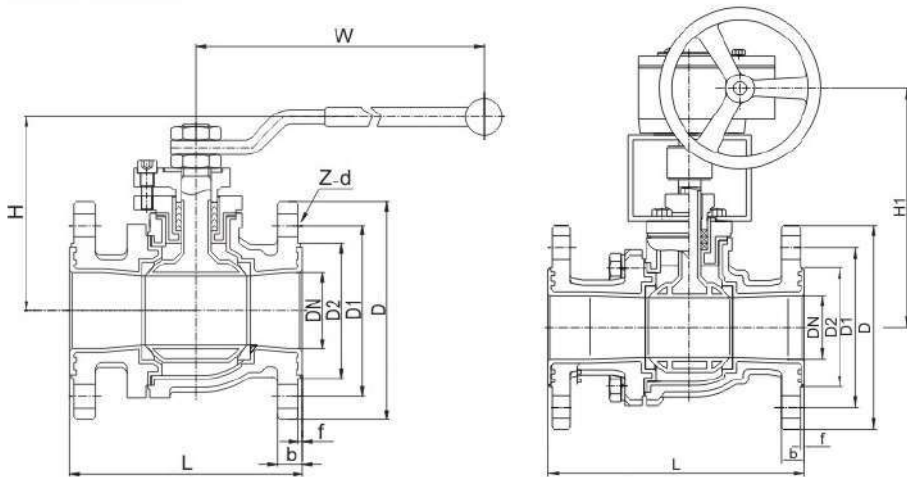

CL150 Dimensions (mm):

IN	L	D	D1	D2	Z-d	f	b	w	H	H1	Wt(Kg)
1/2"	110	89	60.5	35	4-16	2	12	140	100	-	3.5
3/4"	117	98	70	43	4-16	2	12	160	105	-	4
1"	127	108	79.5	51	4-16	2	12	200	110	-	5.5
1 1/4"	140	117	89	64	4-16	2	13	200	130	-	7
1 1/2"	165	127	98.5	73	4-16	2	15	220	135	-	9
2"	178	152	120.5	92	4-19	2	16	220	145	-	15.5
2 1/2"	190	178	139.5	105	4-19	2	18	350	155	-	19.5
3"	203	190	152.5	127	4-19	2	19	400	210	340	30
4"	229	229	190.5	157	8-19	2	24	400	235	360	40
5"	254	254	216	186	8-22	3	24	550	255	405	57
6"	267	279	241.5	216	8-22	3	26	550	285	425	73.5
8"	292	343	298.5	270	8-22	3	29	-	328	505	121
10"	330	406	362	324	12-25	4	31	-	370	540	159

JIS10K Dimensions (mm):

DN	L	D	D1	D2	Z-d	f	b	w	H	H1	Wt(Kg)
15	110	95	70	51	4-16	2	12	140	100	-	3.5
20	117	100	75	56	4-16	2	12	160	105	-	4
25	127	125	90	67	4-19	2	12	200	110	-	5.5
32	140	135	100	76	4-19	2	13	200	130	-	7
40	165	140	105	81	4-19	2	15	220	135	-	9
50	178	155	120	96	4-19	2	16	220	145	-	15.5
65	190	175	140	116	4-19	2	18	350	155	-	19.5
80	203	185	150	126	8-19	2	19	400	210	340	30
100	229	210	175	151	8-19	2	24	400	235	360	40
125	254	250	210	182	8-23	3	24	550	255	405	57
150	267	280	240	212	8-23	3	26	550	285	425	73.5
200	292	330	290	262	12-23	3	29	-	328	505	121
250	330	400	355	325	12-25	4	31	-	370	540	159

LINED BALL VALVE

2-Piece Lined Flanged Ball Valve

PN6*, DN15-DN350 | PN10*, DN15-DN350

MODEL: KHY-LB

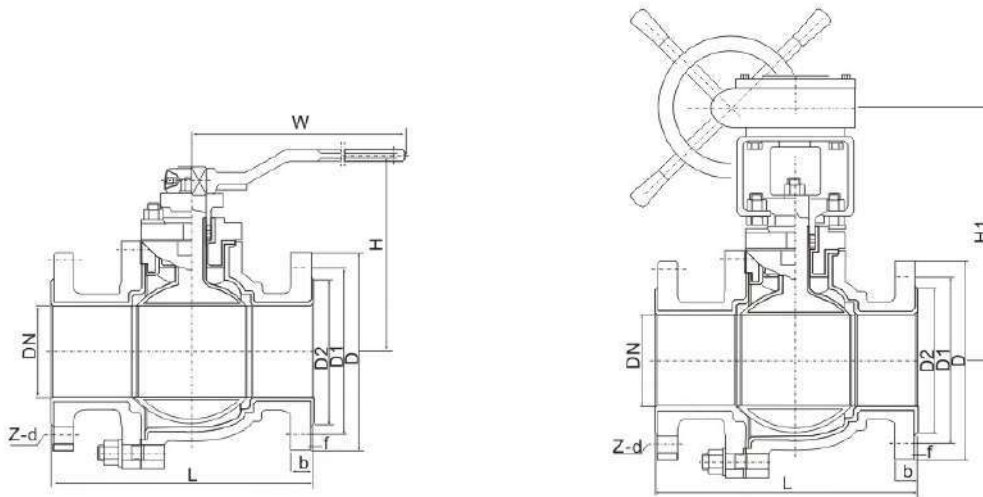

PN6* Dimensions (mm):

DN	L	D	D1	D2	Z-d	f	b	w	H	H1	Wt(Kg)
15	132	85	55	40	4-11	2	12	140	100	-	3.5
20	142	90	65	50	4-11	2	14	160	105	-	4
25	150	100	75	60	4-11	2	14	200	110	-	5.5
32	165	120	90	70	4-14	3	16	200	130	-	7
40	180	130	100	80	4-14	3	16	220	135	-	9
50	200	140	110	90	4-14	3	16	220	145	-	15.5
65	220	160	130	110	4-14	3	16	350	155	-	19.5
80	250	190	150	125	4-18	3	16	400	210	340	30
100	280	210	170	145	4-18	3	18	400	235	360	40
125	320	240	200	175	8-18	3	18	550	255	405	56
150	360	265	225	200	8-18	3	20	550	285	425	72
200	400	320	280	255	8-18	3	22	-	328	505	119
250	450	375	335	310	12-18	4	24	-	370	540	155
300	500	440	395	365	12-22	4	24	-	-	-	202
350	610	490	445	415	12-22	5	24	-	-	-	245

*Note: Some dimensions do not fully conform to EU standards, please be sure to confirm.

PN10* Dimensions (mm):

DN	L	D	D1	D2	Z-d	f	b	w	H	H1	Wt(Kg)
15	132	95	65	45	4-14	2	14	140	100	-	3.5
20	142	105	75	55	4-14	2	14	160	105	-	4
25	150	115	85	65	4-14	2	14	200	110	-	5.5
32	165	140	100	78	4-18	3	16	200	130	-	7
40	180	150	110	85	4-18	3	16	220	135	-	9
50	200	165	125	100	4-18	3	16	220	145	-	15.5
65	220	185	145	120	4-18	3	18	350	155	-	19.5
80	250	200	160	135	8-18	3	20	400	210	340	30
100	280	220	180	155	8-18	3	20	400	235	360	40
125	320	250	210	185	8-18	3	22	550	255	405	56
150	360	285	240	210	8-23	3	24	550	285	425	72
200	400	340	295	265	8-23	3	26	-	328	505	119
250	450	395	350	320	12-23	4	28	-	370	540	155
300	500	445	400	368	12-23	4	29	-	-	-	202
350	610	505	460	428	16-23	5	29	-	-	-	245

*Note: Some dimensions do not fully conform to EU standards, please be sure to confirm.

LINED BALL VALVE

2-Piece Lined Flanged Ball Valve

PN16*, DN15-DN350 | PN25*, DN15-DN300

MODEL: KHY-LB

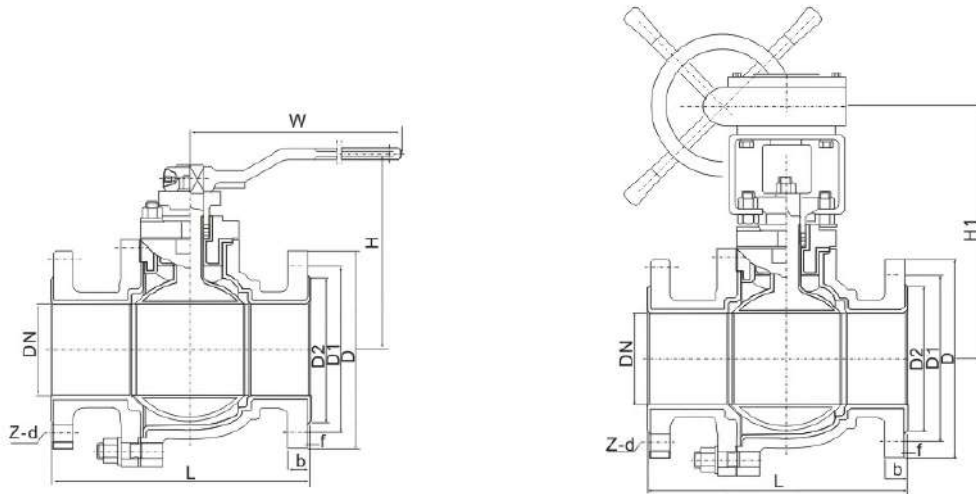

PN16* Dimensions (mm):

DN	L	D	D1	D2	Z-d	f	b	w	H	H1	Wt(Kg)
15	132	95	65	45	4-14	2	15	140	100	-	3.5
20	142	105	75	55	4-14	2	16	160	105	-	4
25	150	115	85	65	4-14	2	16	200	110	-	5.5
32	165	140	100	78	4-18	3	16	200	130	-	7
40	180	150	110	85	4-18	3	17	220	135	-	9
50	200	165	125	100	4-18	3	18	220	145	-	15.5
65	220	185	145	120	4-18	3	20	350	155	-	19.5
80	250	200	160	135	8-18	3	22	400	210	340	30
100	280	220	180	155	8-18	3	24	400	235	360	40
125	320	250	210	185	8-18	3	26	550	255	405	57
150	360	285	240	210	8-23	3	28	550	285	425	73.5
200	400	340	295	265	12-23	3	30	-	328	505	121
250	450	405	355	320	12-25	4	30	-	370	540	159
300	500	460	410	375	12-25	4	30	-	-	-	202
350	610	520	470	435	16-25	5	34	-	-	-	250

*Note: Some dimensions do not fully conform to EU standards, please be sure to confirm.

PN25* Dimensions (mm):

DN	L	D	D1	D2	Z-d	f	b	w	H	H1	Wt(Kg)
15	140	95	65	45	4-14	2	16	140	100	-	3.5
20	152	105	75	55	4-14	2	16	160	105	-	4
25	165	115	85	65	4-14	2	16	200	110	-	5.5
32	178	140	100	78	4-18	3	18	200	130	-	7
40	190	150	110	85	4-18	3	18	220	135	-	9
50	216	165	125	100	4-18	3	20	220	145	-	15.5
65	241	185	145	120	8-18	3	22	350	155	-	19.5
80	283	200	160	135	8-18	3	22	400	210	340	30
100	305	235	190	160	8-23	3	24	400	235	360	44
125	381	270	220	188	8-25	3	28	550	255	405	63
150	403	300	250	218	8-25	3	30	550	285	425	79
200	419	360	310	278	12-25	3	34	-	328	505	124
250	457	425	370	332	12-30	4	36	-	370	540	162
300	500	485	490	390	16-30	4	42	-	510	-	220

*Note: Some dimensions do not fully conform to EU standards, please be sure to confirm.

LINED BALL VALVE

Lined Three-Way Flanged Ball Valve

DN25-DN150 | 1"-6"

MODEL: KHY-LB3W

Technical Specification:

Design Standard	Manufacturer Std.		Manufacturer Std.
Face-to-face Standard	Manufacturer Std.		Manufacturer Std.
Flange Standard	EN 1092-1		ASME B16.5
Inspection and Test Standard	See below*		
Nominal Diameter	DN25-DN150		1"-6"
Nominal Pressure (MPa)	1.0	1.6	CLASS 150
Pressure Test (MPa)	Shell Test	1.5	1.5
	High Pressure Sealing	1.1	1.1
	Low Pressure Sealing	0.6	0.6
Temperature Range (°C)	PFA: -30~200, FEP:-30~150, PO:-10~80		
Applicable Medium	Strong corrosive medium i.e. hydrochloric acid, nitric acid, hydrofluoric acid, liquid chlorine, Sulfuric acid and aqua regia etc.		

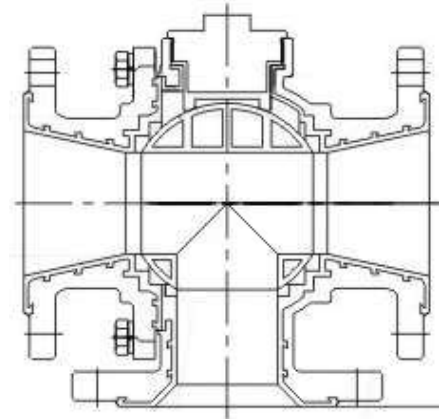

*Note: Standards indicated are general standard used as reference, some variations exist. Other standard or tests may be available on request for fee.

Pressure Temperature Curve

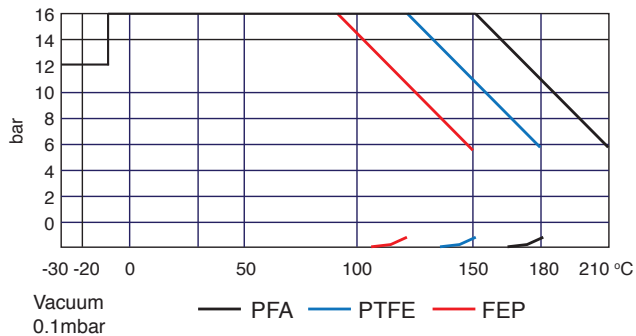

Flow Characteristic

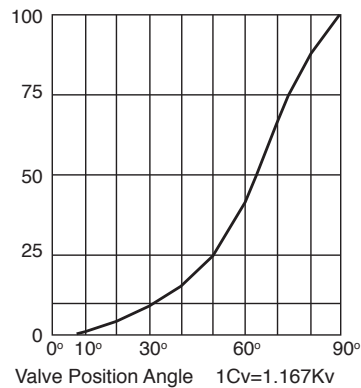

Optional Flow Arrangements:

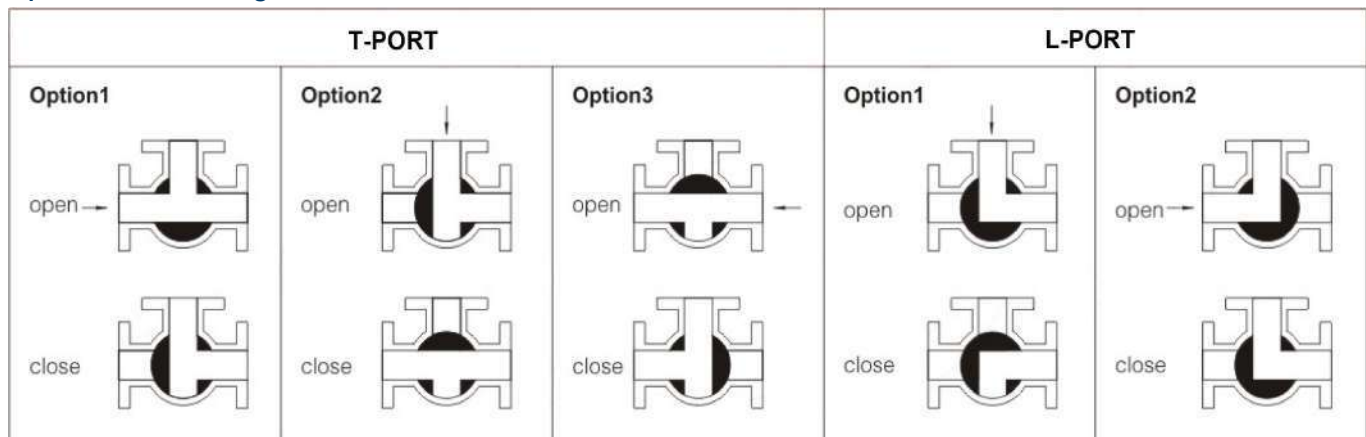

LINED BALL VALVE

Lined Three-Way Flanged Ball Valve
 PN10*, DN25-DN150 | PN16*, DN25-DN150

MODEL: KHY-LB3W

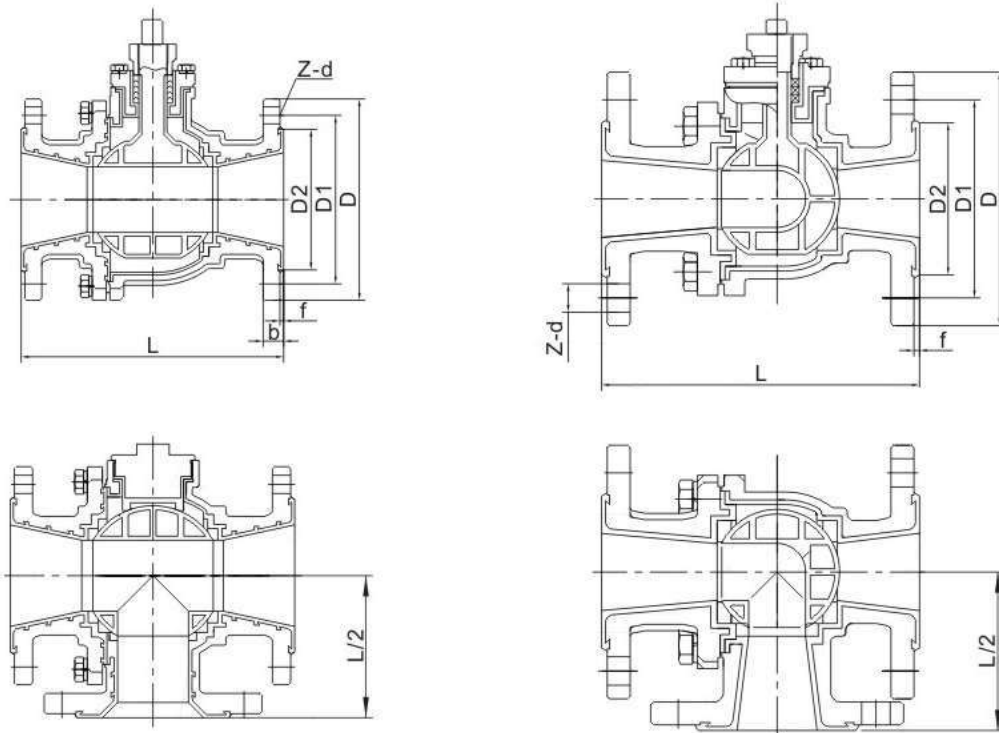

PN10* / PN16* Dimensions (mm):

DN	L	D	D1	D2	Z-d	f	b
25	165	120	85	65	4-14	2	14
32	180	140	100	78	4-18	3	16
40	200	150	110	85	4-18	3	16
50	200	165	125	100	4-18	3	16
65	240	185	145	120	4-18	3	18
80	250	200	160	135	8-18	3	20
100	280	220	180	155	8-18	3	20
125	360	250	210	185	8-18	3	22
150	370	285	240	210	8-23	3	24

*Note: Some dimensions do not fully conform to EU standards, please be sure to confirm.

LINED BALL VALVE

Lined Three-Way Flanged Ball Valve
CL150, 1"-6"

MODEL: KHY-LB3W

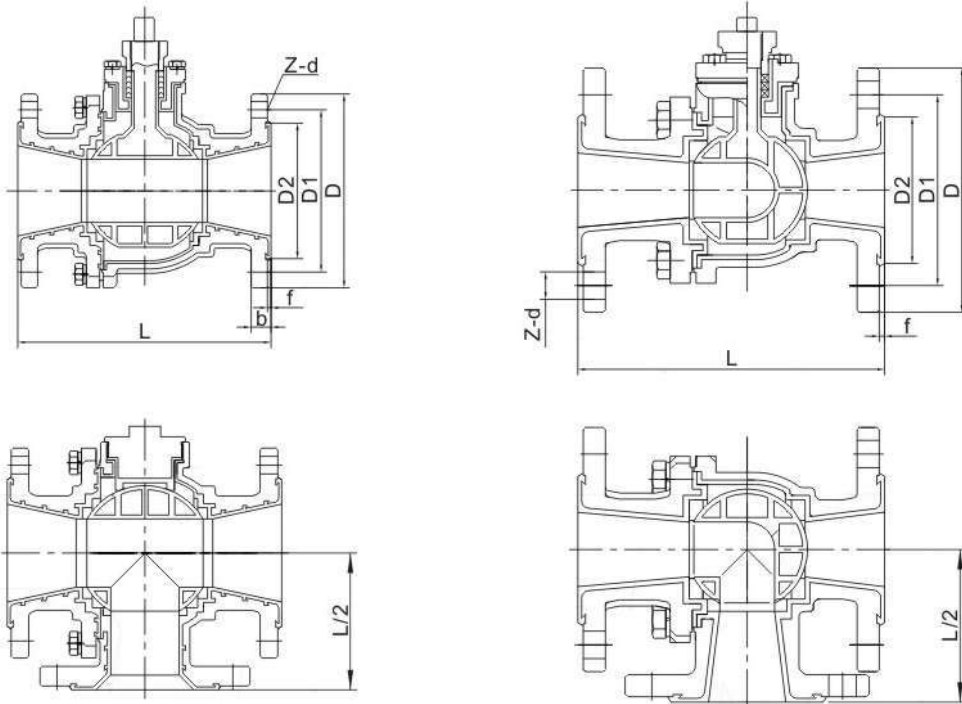

CL150 Dimensions (mm):

IN	L	D	D1	D2	Z-d	f	b
1"	165	108	79.5	51	4-16	2	12
1¼"	180	117	89	64	4-16	2	13
1½"	200	127	98.5	73	4-16	2	15
2"	200	152	120.5	92	4-19	2	16
2½"	240	178	139.5	105	4-19	2	18
3"	250	190	152.5	127	4-19	2	19
4"	280	229	190.5	157	8-19	2	24
5"	360	254	216	186	8-22	3	24
6"	370	279	241.5	216	8-22	3	26

LINED BALL VALVE

Lined Tank Bottom Flanged Ball Valve
DN25-DN200

MODEL: KHY-LBTB

» **Body Material**

ASTM CF8M, CF8, CF3,CF3M, WCB

» **Size Range**

DN: 25 - 200

» **Pressure Rating**

PN6, PN10

» **End Connection**

Flanged

» **Lining Material**

PFA, FEP, PO

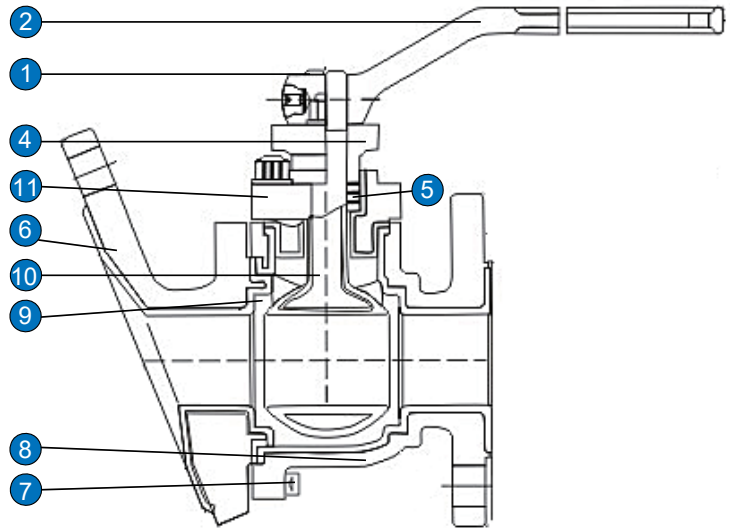

Materials List:

NO	Name	Material		
1	Nut	A194 2H	A194 8	A194 8M
2	Lever	A216 WCB	A351 CF8 A351 CF8M	A351 CF3 A351 CF3M
3	Locating Plate	1025, SS304		
4	Gland	A216 WCB	A351 CF8 A351 CF8M	A351 CF3 A351 CF3M
5	Packing	PTFE		
6	Cap	A216 WCB+Lining	A351 CF8 CF8M+Lining	A351 CF3 CF3M+Lining
7	Body bolt	A193 B7	A320 B8	A193 B8M
8	Body	A216 WCB+Lining	A351 CF8 CF8M+Lining	A351 CF3 CF3M+Lining
9	Seat	PTFE, RPTFE, PEEK		
10	Ball/stem	A216 WCB+Lining	A351 CF8 CF8M+Lining	A351 CF3 CF3M+Lining
11	Bonnet	A216 WCB+Lining	A351 CF8 CF8M+Lining	A351 CF3 CF3M+Lining

Technical Specification:

Design Standard		Manufacturer Std.		Manufacturer Std.
Face-to-face Standard		Manufacturer Std.		Manufacturer Std.
Flange Standard		EN 1092-1		ASME B16.5
Inspection and Test Standard		See below*		
Nominal Diameter		DN25-DN200		1"-8"
Nominal Pressure (MPa)		1.0	1.6	CLASS 150
Pressure Test (MPa)	Shell Test	1.5	1.5	1.5
	High Pressure Sealing	1.1	1.1	1.1
	Low Pressure Sealing	0.6	0.6	0.6
Temperature Range (°C)		PFA: -30~200, FEP:-30~150, PO:-10~80		
Applicable Medium		Strong corrosive medium i.e. hydrochloric acid, Nitric acid, Hydrofluoric acid, Liquid chlorine, Sulfuric Acid and Aqua regia etc.		

*Note: Standards indicated are general standard used as reference, some variations exist. Other standard or tests may be available on request for fee.

LINED BALL VALVE

Lined Tank Bottom Flanged Ball Valve
 PN6*, DN25-DN200 | PN10*, DN25-DN200

MODEL: KHY-LBTB

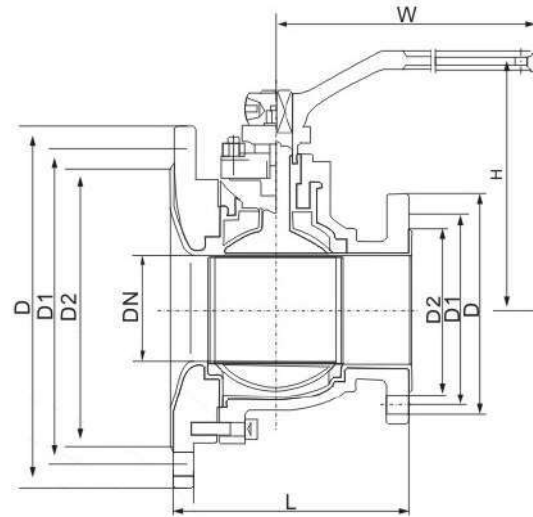
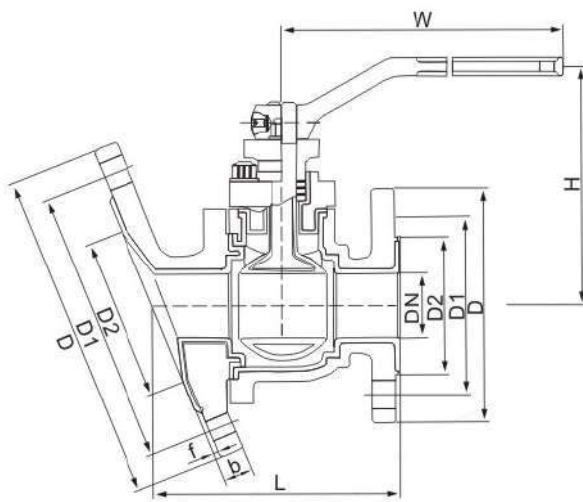

PN10* / PN6* Dimensions (mm):

DN	L	D	D1	D2	Z-d	f	b	H	w
25/50	130	115/140	85/110	65/90	4-14/4-14	2/3	14/16	110	140
32/65	140	140/160	100/130	78/110	4-18/4-14	3/3	16/16	130	200
40/65	150	150/160	110/130	85/110	4-18/4-14	3/3	16/16	135	200
40/80	150	150/190	110/150	85/125	4-18/4-18	3/3	16/18	135	200
50/80	165	165/190	125/150	100/125	4-18/4-18	3/3	16/18	145	250
50/100	165	165/210	125/170	100/145	4-18/4-18	3/3	16/18	145	250
65/100	175	185/210	145/170	120/145	4-18/4-18	3/3	18/18	155	250
65/125	175	185/240	145/200	120/175	4-18/8-18	3/3	18/20	155	250
80/125	250	200/240	160/200	135/175	4-18/8-18	3/3	20/20	210	350
80/150	250	200/265	160/225	135/200	4-18/8-18	3/3	20/20	210	350
100/150	280	220/265	180/225	155/200	8-18/8-18	3/3	20/20	235	350
100/200	280	220/320	180/280	155/255	8-18/8-18	3/4	20/22	235	350

*Note: Some dimensions do not fully conform to EU standards, please be sure to confirm.

LINED VALVE

Fluorine Plastic Performance

Performance	Item		PTFE	PVDF	FEP	PFA	PO	PE	PP
			F4	F2	F46	PFA	PO	PE	PP
Physical Performance	Specific Gravity	g/cm3	2.1-2.2	1.76	2.1-2.2	2.1-2.2	0.92	0.92	0.92
	Water absorption	%	0.001~0.005	0.04	≤0.01	≤0.01	0.005	0.005	0.005
	Shrinkage rate of finished product	%	1~5	2.0	2~5	1~5	1~2	1~2	1~2
	Embrittlement coefficient	10-5/K	10~12	8.5~15.3	8.3~10.5	8.3~12	-	-	-
	Embrittlement temperature T1	°C	-180~-195	-62	-260	-180~-195	-40	-40	-20
	Hot resistance T2	°C	260	150	204	260	100	100	100
	Recommend working temperature T3	°C	≤180	≤100	≤150	≤200	≤85	≤85	≤85
Mechanical Performance	Hardness	SOSIXO	D50-65	D80	(R45)	D50-65	D40	D40	D40
	Friction coefficient f	-	0.06	0.14-0.17	0.06-0.11	0.06-0.11	-	-	-
	Tensile strength σ_b	MPa	13.7-24.5	45-48.3	20.0-24.5	14-28	≥10	6.9-14	7.5-14
	Bending strength σ_w	MPa	10.7-13.7	-	-	15-28	-	-	-
	Compression strength σ_y	MPa	111	68.6	-	111	-	-	-
	Impact strength σ_k	KJ/m2	16	19.7	Continuous	1 +	-55	45	50
	Ultimate elongation $\Delta\lambda$	%	250-350	30-300	250-270	300-500	480	300-600	600-700
	Breakdown voltage v	KV/mm	25~40	10.2	40	25~40	-	-	-
Processing Performance	Compression molding		Good	Good	Good	Good	Good	Good	Good
	Injection molding		-	Good	Good	Good	Good	Good	Good
	Lamination		Good	Good	Good	Good	Good	Good	Good
	Lamination		Good	Good	Good	Good	Good	Good	Good

LINED VALVE

Fluorine Plastic Performance

Corrosion Resistance performance (theoretical reference)

Medium	Concentration (%)	Temperature (°C)	PTFE	PVDF	FEP	PFA	PO	PE	PP
Sulfuric acid	10~98	Normal temperature ~100	A	A~B	A	A	Concentration ≤50%	Concentration ≤60%	A
Nitric acid	5~98	Normal temperature ~100	A	A	A	A	Concentration ≤30%	Concentration ≤60%	A
Hydrochloric acid	10~38	Normal temperature ~100	A	A	A	A	Concentration ≤38%	Concentration ≤60%	A~B
Acetic acid	10~100	Normal temperature ~100	A	A~B	A	A	Concentration ≤10%	Concentration ≤60%	A
Chromic acid	50~100	Normal temperature ~70	A	A~B	A	A	Concentration ≤30%	Concentration ≤20%	A
Phosphoric acid	50~85	Normal tempera- ture~100	A~B	D	A~B	A~B	Concentration ≤85%	Concentration ≤80%	A
Trichloroethane	100	Normal temperature	C	B	C	C	X	X	X
Copper-sulfate	15	Normal temperature	A	C	A	A	Concentration ≤90%	Concentration ≤80%	A
Diethyl ether	100	Normal temperature	B	C	B	B	X	X	X
Ethyl acetate	100	Normal temperature	B	A	B	B	X	X	X
Petrol	100	Normal temperature	A	A~B	A	A	X	X	X
Hydrogen peroxide	3~30	Normal temperature	A	A	A	A	Concentration ≤30%	Concentration ≤60%	A
Nitrobenzene	100	Normal temperature	A	A~B	A	A	X	X	X
Superalkali	10-50	Normal tempera- ture~100	A	A	A	A	Concentration ≤80%	Concentration ≤60%	A
Sodium Hypochlorite	-	70	A	B	A	A	Concentration ≤80%	Concentration ≤60%	A~B
Hydroxyl acid	40~99	-10~30	A~B	B	A~B	A~B	Concentration ≤80%	Concentration ≤60%	A~B
Oleum	20	Normal temperature	A	B	A	A	X	X	X
Acrylonitrile	-	Normal temperature	B	C	B	B	-	-	-
Aniline	100	Normal temperature	B	B	B	B	Concentration ≤60%	Concentration ≤20%	B
Benzene	100	Normal temperature	B	C	B	B	X	X	X
Butyl acetate	100	Normal temperature	B	C	B	B	Concentration ≤60%	Concentration ≤20%	B
Tetrachloromethane	Reagent grade	Normal temperature	B	C	B	B	X	X	X

Data indicated are theoretical value for reference. Depending on valve type and DN size, temperature limitation may be reduced accordingly.

A = Excellent, B = Good, C = OK, D = Poor

Many factors influence corrosion rating such as temperature fluctuation, concentration and aeration of fluids, high velocity or abrasions in the fluid steam, etc. The physical properties of material are affected differently by each corrosive media and sometimes it is inevitable one property is sacrificed for gain in another property. The corrosion data is provided as a comprehensive theoretical guide indicating the possible range, user must consider all parameters and exercise sound engineering judgment in material selection.