

STOP GLOBE VALVE TYPE 675

CHARACTERISTIC:

Diameter	-	6 -10 mm;
Pressure	-	320 bar;
Temperature	-	up to 600°C;
Medium	-	water, steam and other non-toxic, non aggressive media and engine fuel.

VERSIONS:

type / ends / body material / disc and disc ring / others

Example: 675 / --- / --- / --- /---

Example: 675 / S / A / --- /---

Ends	Sign	Body material	Sign	Disc and disc ring	Sign	Others	Sign
Standard- threaded	---	(P250GH) C 22.8	---	Standard	---	-----	---
Butt weld ends	S	16Mo3	U	Stellit ring	L		
		13CrMo4-5	A				
		11CrMo9-10	B				
		14MoV6-3	C				

APPLICATION:

Stop globe valve is designed to open and stop the flow. The valve is not supposed to be used as a regulating device.

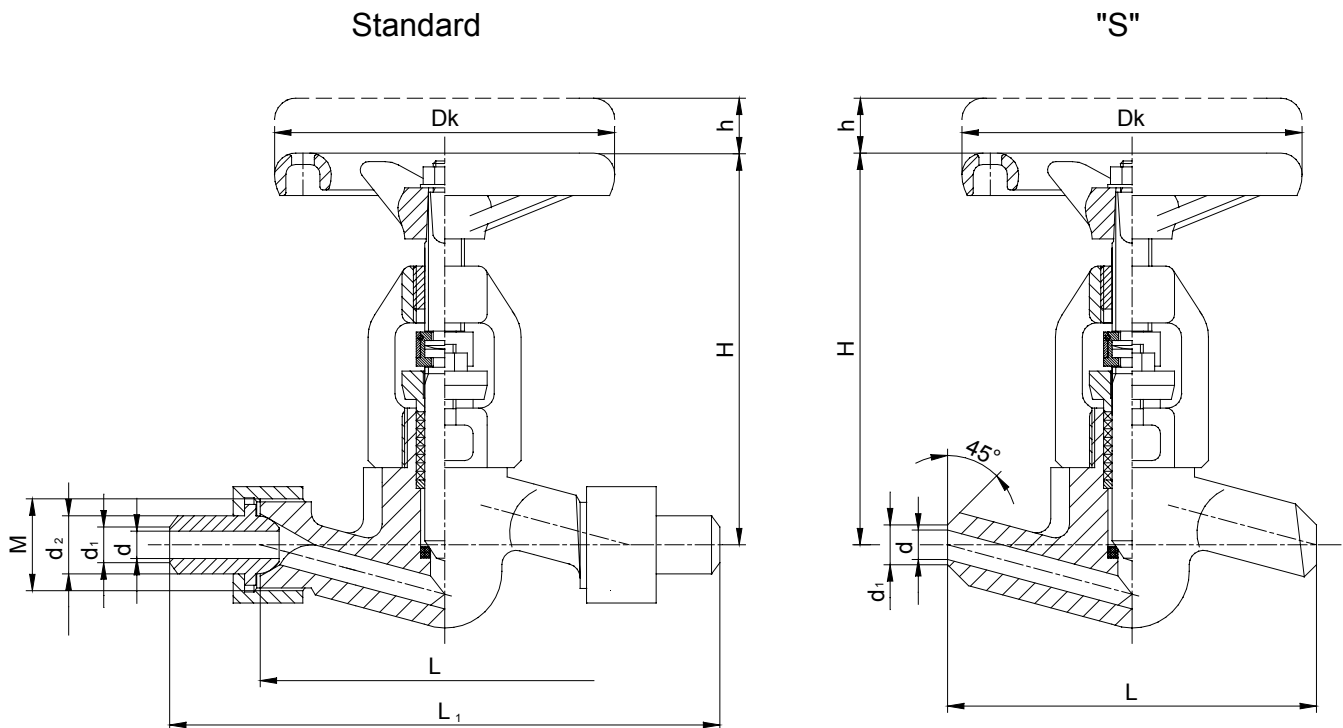

MATERIALS:

Versions	Standard	U	A	B	C
Parts	T _{MAX} 450°C	T _{MAX} 530°C	T _{MAX} 560°C	T _{MAX} 600°C	T _{MAX} 570°C
Body, bonnet	(P250GH) C22.8 (1.0460)	16Mo3 (1.7335)	13CrMo4-5 (1.7335)	11CrMo9-10 (1.7383)	14MoV6-3 (1.7715)
Stem	X17CrNi16-2 (1.4057), X39CrNi17-1 (1.4122)				
Seat ring	G 18 8 Mn (1.4370) or Stellite				
Upper Stem	X17CrNi16-2 (1.4057), X39CrNi17-1 (1.4122)				
Packing rings	Grafit				
Wheel	Cast iron				

Special materials on request; modifications reserved.

DIMENSIONS:

DN	d	d ₁	d ₂	M	L	L ₁	H	h	Dk	Weight
6	6	8	12	M27 x 2	130	170	150	12	100	2,50
8	8	12	16	M27 x 2	130	170	150	12	100	2,50
10	10	14	18	M27 x 2	130	170	150	12	100	2,50

Dimensions in mm; modifications reserved.

TECHNICAL DATA:

Body material	PN	Maximal working pressure at working temperature																
		20°C	100°C	150°C	200°C	250°C	300°C	350°C	400°C	450°C	480°C	500°C	520°C	530°C	540°C	560°C	570°C	600°C
(P250GH)C 22.8 (1.0460)	320	320,00	297,10	281,90	266,60	243,80	220,90	205,70	190,40	105,10								-
16Mo3 (1.5415)	320	320,00	320,00	320,00	320,00	312,30	274,20	259,00	243,80	236,10	179,50	141,70	89,90	71,60				-
13CrMo4-5 (1.7335)	320	320,00	320,00	320,00	320,00	320,00	318,40	304,70	289,50	274,20	234,90	208,70	143,20	118,80	92,90	60,90	50,20	-
14MoV6-3 (1.7715)	320	320,00	320,00	320,00	320,00	320,00	320,00	320,00	318,50	309,30	307,00	294,10	227,00	199,60	172,20	131,00	111,20	-
11CrMo9-10 (1.7383)	320	320,00	320,00	320,00	320,00	320,00	320,00	312,30	297,10	281,90	236,10	205,70	156,90	137,10	118,80	88,30	77,70	51,8

MOUNTING AND OPERATING:

The valve can only be mounted and operated by skilled, properly trained and qualified personnel. Incorrect assembly or operation of the valve may have substantial impact on the entire system such as fluid leakage, reduction in system's function etc.

Before a valve is installed the pipeline must be clean from any mechanical impurities. The compatibility of critical parameters of the flow must be checked with the parameters of the valve. Stop globe valve can be mounted to a pipe-line in any position. The direction of flow should only comply with the arrow marked on the body. The valve should be operated strictly with its assign. In order to provide valve's reliability the following suggestions must be observed:

- medium flowing through the valve is supposed to be clean out of any mechanical impurities;
- the valve must be protected from any mechanical damages during its work;
- nominal parameters marked on the valve must be observed.