

STOP GLOBE VALVE TYPE 673

CHARACTERISTIC:

- Diameter - 15 - 100 mm;
- Pressure - 250 bar;
- Temperature - up to 670°C;
- Medium - water, steam and other non-toxic, non aggressive liquid and gas media.

VERSIONS:

type / ends / body material / disc and disc ring / drive type

Example: 673 / --- / --- / --- / ---

Example: 673 / K / U / L / ---

Ends	Sign	Body material	Sign	Disc and disc ring	Sign	Drive type	Sign
Standard-butt weld ends	---	(P250GH) C 22.8	---	Standard	---	Hand wheel	---
Socket weld	SW	16Mo3	U	Stellit ring	L	AUMA drive	NA
Flange by DIN or ANSI, or Threaded	K	13CrMo4-5	A			NWA drive	NW
		11CrMo9-10	B			MODACT drive	NM
		14MoV6-3	C			Pneumatic drive	NP
		X10CrMoVNb9-10	E				

APPLICATION:

Stop globe valve with throttle plug is designed to open and stop the flow. The valve is supposed to be used as a regulating device.

DN 10 ÷ 15

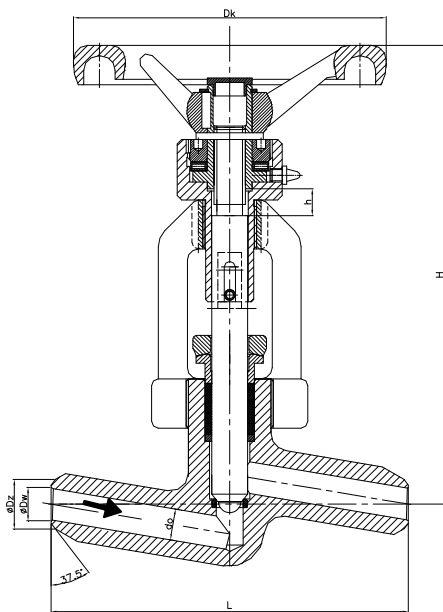

DN 20 ÷ 50

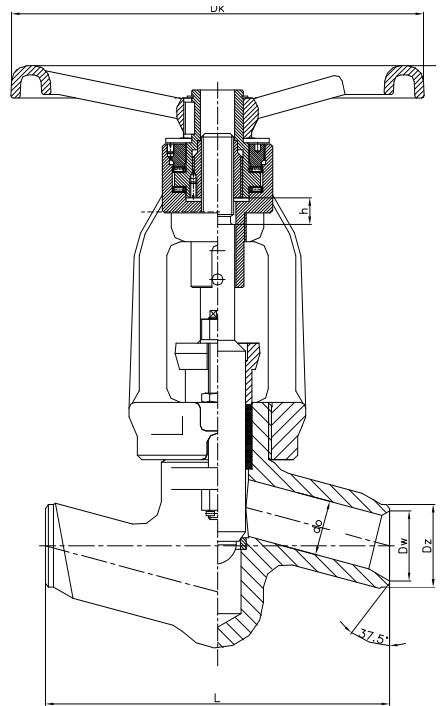

DN 65 ÷ 100

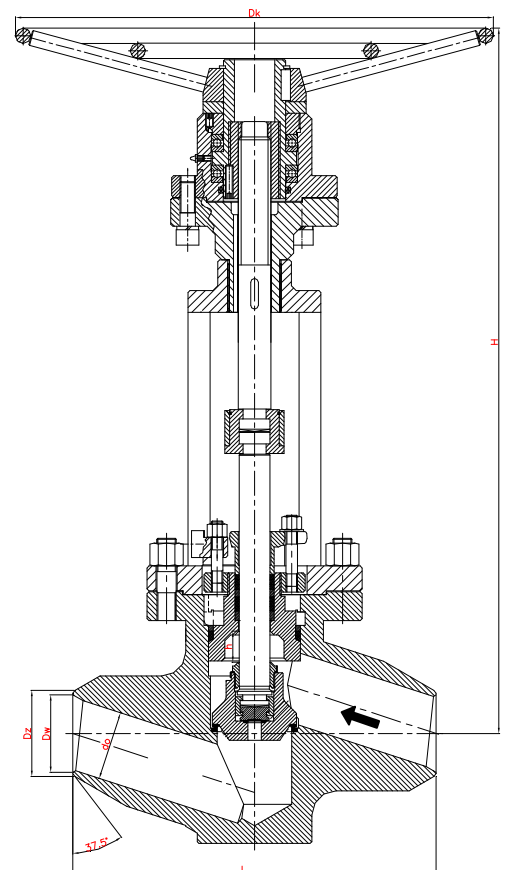

"SW"

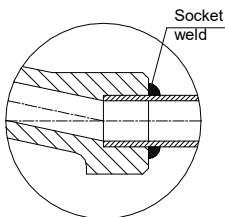

"K"

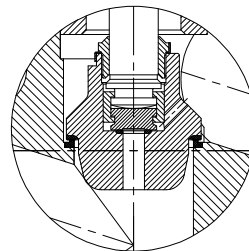
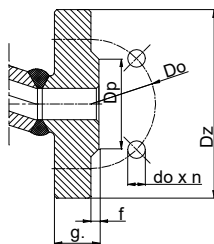

MATERIALS:

Versions	Standard	U	A	B	C	E
Parts	T _{MAX} 450°C	T _{MAX} 530°C	T _{MAX} 560°C	T _{MAX} 600°C	T _{MAX} 570°C	T _{MAX} 670°C
Body	(P250GH) C22.8 (1.0460)	16Mo3 (1.5415)	13CrMo4-5 (1.7335)	11CrMo9-10 (1.73813)	14MoV6-3 (1.7715)	X10CrMoVNb9-10 (1.4903)
Bonnet	DN 15-25 13CrMo4-5 (1.7335) DN 32-125 G17CrMo5-5 (1.7357)					11CrMo9-10 (1.7383)
Stem DN 15-65	X39CrNi17-1 (1.4122), X22CrMoV12-1 (1.4923)					
Disc DN 80-125	11CrMo9-10 (1.7383)	11CrMo9-10 (1.7383)	11CrMo9-10 (1.7383)	11CrMo9-10 (1.7383)	11CrMo9-10 (1.7383)	X10CrMoVNb9-10 (1.4903)
Seat ring	BT9 or Stellite					
Upper stem	X17CrNi16-2 (1.4057), X39CrNi17-1 (1.4122)					
Wheel	Cast iron					

Special materials on request; modifications reserved.

DIMENSIONS:

Standard – Butt weld ends						H	h	Dk
DN	d	Dz	Dw	L	Weight			
10	10	20	12	160	2,90	205	12	140
15	14	22	16					
20	20	28	19,5	160	7,50	266	19	200
	18							
25	24	35	26,5	300	30,50	418	23	360
32	30	44	32,5					
40	38	50	38,5					
	36							
50	44	62	45	340	42,50	714	45	GNR 700
	42							
65	62	77	59,5	380	85,00	637	36	GNR 500
	56							
80	76	117	93	430	127,00	720	50	GNR 500
100	92	144	116,5					

Dimensions in mm; modifications reserved.

TECHNICAL DATA:

Body material	PN	Maximal working pressure at working temperature																
		20°C	100°C	150°C	200°C	250°C	300°C	350°C	400°C	450°C	480°C	500°C	520°C	530°C	540°C	560°C	570°C	600°C
(P250GH)C 22.8 (1.0460)	250	250,0	250,0	250,0	250,0	250,0	250,0	250,0	250,0	250,0	165,0	-	-	-	-	-	-	-
16Mo3 (1.5415)	250	250,0	250,0	250,0	250,0	250,0	250,0	250,0	250,0	250,0	250,0	222,0	176,0	141,0	112,0	-	-	-
13CrMo4-5 (1.7335)	250	250,0	250,0	250,0	250,0	250,0	250,0	250,0	250,0	250,0	250,0	250,0	224,0	186,0	146,0	95,0	79,0	-
14MoV6-3 (1.7715)	250	250,0	250,0	250,0	250,0	250,0	250,0	250,0	250,0	250,0	250,0	250,0	250,0	250,0	205,0	174,0	-	-
11CrMo9-10 (1.7383)	250	250,0	250,0	250,0	250,0	250,0	250,0	250,0	250,0	250,0	250,0	250,0	246,0	215,0	186,0	138,0	122,0	81,0
Body material	PN	Maximal working pressure at working temperature																
		20°C	530°C	540°C	550°C	560°C	570°C	580°C	590°C	600°C	610°C	620°C	630°C	640°C	650°C	660°C	670°C	
X10CrMoVNb9-1 (1.4903)	250	250,0	250,0	250,0	250,0	250,0	250,0	250,0	250,0	250,0	224,0	198,0	174,0	155,0	134,0	117,0	100,0	86,0

MOUNTING AND OPERATING:

The valve can only be mounted and operated by skilled, properly trained and qualified personnel. Incorrect assembly or operation of the valve may have substantial impact on the entire system such as fluid leakage, reduction in system's function etc.

Before a valve is installed the pipeline must be clean from any mechanical impurities. The compatibility of critical parameters of the flow must be checked with the parameters of the valve. Stop globe valve can be mounted to a pipe-line in any position. The direction of flow should only comply with the arrow marked on the body. The valve should be operated strictly with its assign. In order to provide valve's reliability the following suggestions must be observed:

- medium flowing through the valve is supposed to be clean out of any mechanical impurities;
- the valve must be protected from any mechanical damages during its work;
- nominal parameters marked on the valve must be observed.