

STOP GLOBE VALVE - ANGULAR TYPE 555

CHARACTERISTIC:

Diameter	-	15 -50 mm;
Pressure	-	160 bar;
Temperature	-	up to 560°C;
Medium	-	water, steam and other non-toxic, non aggressive liquid and gas media and engine fuel.

VERSIONS:

type / ends / body material / disc and disc ring / drive type

Example: 555 / --- / --- / --- / ---

Example: 555 / S / U / R / ---

Ends	Sign	Body material	Sign	Disc and disc ring	Sign	Drive type	Sign
Standard - flanged	---	(P250GH) C 22.8 or GP240GH	---	Standard	---	Hand wheel	---
Butt weld ends	S			Throttle plug	R	AUMA drive	NA
Socket weld	SW	16Mo3 or G20Mo5	U	Throttle plug	RR	NWA drive	NW
Threaded	G	13CrMo4-5 or G17CrMo5-5	A	Throttle plug	Q	MODACT drive	NM
				STELLIT ring	L		

APPLICATION:

Stop globe valve is designed to open and stop the flow. The valve is not supposed to be used as a regulating device. For regulation the version „R” with throttling plug should be applied.

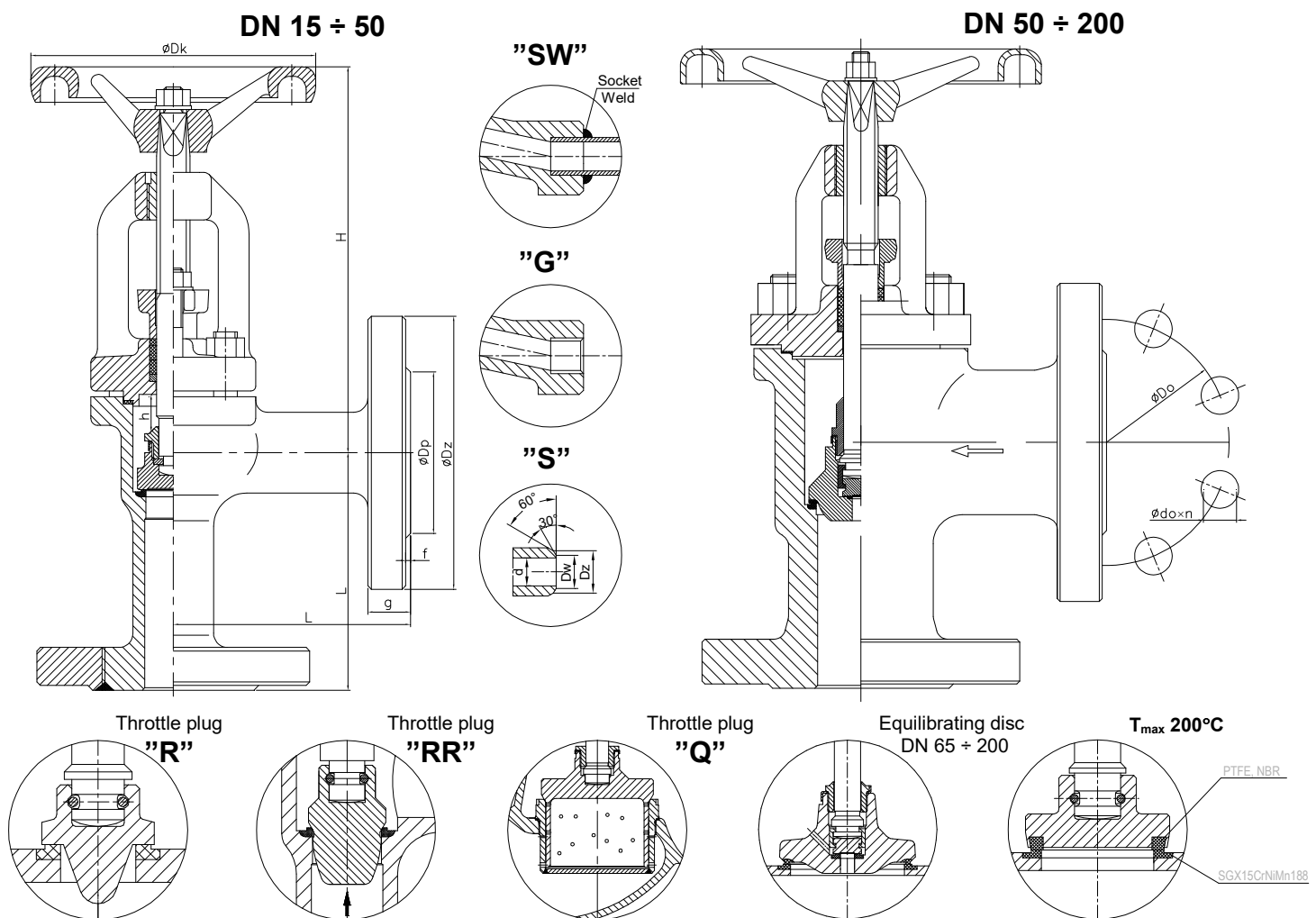

MATERIALS:

Versions	Standard	U	A	Other versions
Parts	T _{MAX} 450°C	T _{MAX} 530°C	T _{MAX} 560°C	-
Body, bonnet DN 15-40	(P250GH) C22.8 (1.0460)	16Mo3 (1.5415)	13CrMo4-5 (1.7335)	(P250GH) C22.8, 16Mo3, 13CrMo4-5
Seat ring DN15-25	X17CrNi16-2 (1.4057)			Stellit
Seat ring	G 18 8 Mn (1.4370)			
Disc DN 15-50	X30Cr13 (1.4028)	X30Cr13 (1.4028)	13CrMo4-5 (1.7335)	X30Cr13, 13CrMo4-5
Disc ring	G 18 8 Mn (1.4370)			Stellit
Stem	X20Cr13 (1.4021)	X17CrNi16-2 (1.4057)	X39CrMo17-1 (1.4122)	BT9
Gasket	Grafit + austenite			
Wheel	Cast iron			

Special materials on request; modifications reserved.

DIMENSIONS:

Standard - flanged													
DN	d	Dz	Dp	Do	do	n	L	g.	f	H	h	Dk	Weight
15	15	105	45	75	14	4	105	20	2	175	13	120	5,40
20	20	130	58	90	18	4	115	22	2	215	13	160	9,70
25	24	140	68	100	18	4	115	24	2	215	13	160	10,60
32	30	155	78	110	22	4	130	24	2	245	16	200	15,60
40	38	170	88	125	22	4	130	28	3	245	18	200	17,30
50	47	195	102	145	26	4	150	30	3	300	22	250	29,00

Dimensions in mm; modifications reserved.

TECHNICAL DATA:

Body material	PN	Maximal working pressure at working temperature																
		20°C	100°C	150°C	200°C	250°C	300°C	350°C	400°C	450°C	480°C	500°C	510°C	520°C	530°C	540°C	550°C	560°C
(P250GH)C 22.8 (1.0460)	160	160,0	137,1	133,3	125,7	116,5	102,8	99,0	91,4	52,5	-	-	-	-	-	-	-	-
16Mo3 (1.5415)	160	160,0	160,0	160,0	160,0	148,5	129,5	121,9	114,2	110,4	83,6	70,8	56,3	44,9	35,8			
13CrMo4-5 (1.7335)	160	160,0	160,0	160,0	160,0	160,0	148,5	137,1	129,5	121,9	111,3	104,3	88,3	71,6	59,4	46,4	37,3	30,4

MOUNTING AND OPERATING:

The valve can only be mounted and operated by skilled, properly trained and qualified personnel. Incorrect assembly or operation of the valve may have substantial impact on the entire system such as fluid leakage, reduction in system's function etc.

Before a valve is installed the pipeline must be clean from any mechanical impurities. The compatibility of critical parameters of the flow must be checked with the parameters of the valve. Stop globe valve can be mounted to a pipe-line in any position. The direction of flow should only comply with the arrow marked on the body. The valve should be operated strictly with its assign. In order to provide valve's reliability the following suggestions must be observed:

- medium flowing through the valve is supposed to be clean out of any mechanical impurities;
- the valve must be protected from any mechanical damages during its work;
- nominal parameters marked on the valve must be observed.