

GATE VALVE

Cast Steel OS&Y to DIN
PN25, DN40-DN150

KSD-GTF PN25-F5

» Features

Cast steel body construction providing liberal strength to meet most conditions
Integral yoke & bonnet; Outside screw & yoke, bolted bonnet
Single flexible wedge disc compensates for deformation of body due to pipe stresses
Seal welded seat ring eliminates leak path behind rings and for long trouble-free service
Available in flanged end connection; butt weld end also available

» Body Material

DIN 17245 GS-C25

» Standards

Basic design to DIN 3352
Face-to-Face acc. to DIN 3202-F5
Flange Dimensions acc. to DIN 2544
Inspection & test according to EN 12266-1

» Temperature Range

-20°C to 425°C (-4°F to 800°F)

» Note

For non-horizontal installation, please ensure to consult with us separately, as special request must be generated to ensure proper function.

Materials List:

NO	PART NAME	MATERIAL
1	BODY	DIN 17245 GS-C25 + 13Cr
2	WEDGE	DIN 17245 GS-C25 + 13Cr
3	STEM	ASTM A182 F6a
4	BONNET BOLT	ASTM A193 B7
5	BONNET NUT	ASTM A194 2H
6	GASKET	SS304+FLEXIBLE GRAPHITE
7	BONNET	DIN 17245 GS-C25
8	STEM PACKING	FLEXIBLE GRAPHITE
9	GLAND EYEBOLT	ASTM A193 B7
10	GLAND NUT	ASTM A194 2H
11	PIN	AISI 1025
12	GLAND FLANGE	DIN 17245 GS-C25
13	NIPPLE	COPPER ALLOY
14	STEM NUT	ASTM A439 D2
15	RETAINING NUT	AISI 1025
16	HANDWHEEL	DUCTILE IRON
17	LOCK NUT	AISI 1025

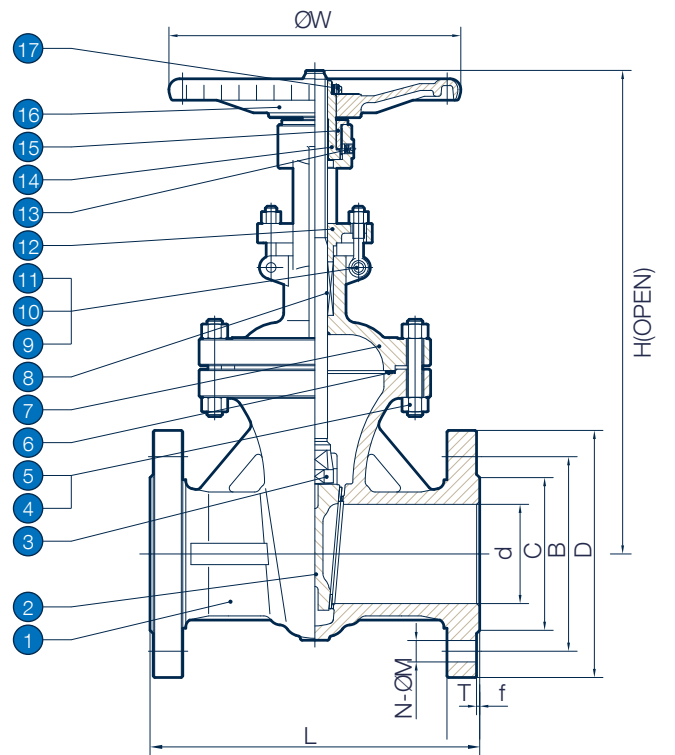

Dimensions (mm):

SIZE		d	D	B	C	W	L	H	T	f	N	M
DN	NPS											
40	1½	40	150	110	88	180	240	365	18	3	4	18
50	2	50	165	125	102	200	250	410	20	3	4	18
65	2½	65	185	145	122	220	270	462	22	3	8	18
80	3	80	200	160	138	250	280	518	24	3	8	18
100	4	100	235	190	162	280	300	605	24	3	8	22
125	5	125	270	220	188	300	325	678	26	3	8	26
150	6	150	300	250	218	300	350	798	28	3	8	26

GATE VALVE

Cast Steel OS&Y to DIN
PN25, DN200-DN600

KSD-GTF PN25-F5

» Features

Cast steel body construction providing liberal strength to meet most conditions
Integral yoke & bonnet; Outside screw & yoke, bolted bonnet
Single flexible wedge disc compensates for deformation of body due to pipe stresses
Seal welded seat ring eliminates leak path behind rings and for long trouble-free service
Available in flanged end connection; butt weld end also available

» Body Material

DIN 17245 GS-C25

» Standards

Basic design to DIN 3352
Face-to-Face acc. to DIN 3202-F5
Flange Dimensions acc. to DIN 2544
Inspection & test according to EN 12266-1

» Temperature Range

-20°C to 425°C (-4°F to 800°F)

» Note

For non-horizontal installation, please ensure to consult with us separately, as special request must be generated to ensure proper function.

Materials List:

NO	PART NAME	MATERIAL
1	BODY	DIN 17245 GS-C25 + 13Cr
2	WEDGE	DIN 17245 GS-C25 + 13Cr
3	STEM	ASTM A182 F6a
4	BONNET BOLT	ASTM A193 B7
5	BONNET NUT	ASTM A194 2H
6	GASKET	SS304+FLEXIBLE GRAPHITE
7	BONNET	DIN 17245 GS-C25
8	STEM PACKING	FLEXIBLE GRAPHITE
9	GLAND EYEBOLT	ASTM A193 B7
10	GLAND NUT	ASTM A194 2H
11	PIN	AISI 1025
12	GLAND FLANGE	DIN 17245 GS-C25
13	YOKE	DIN 17245 GS-C25
14	NIPPLE	COPPER ALLOY
15	STEM NUT	ASTM A439 D2
16	RETAINING NUT	AISI 1025
17	HANDWHEEL	DUCTILE IRON
18	LOCK NUT	AISI 1025

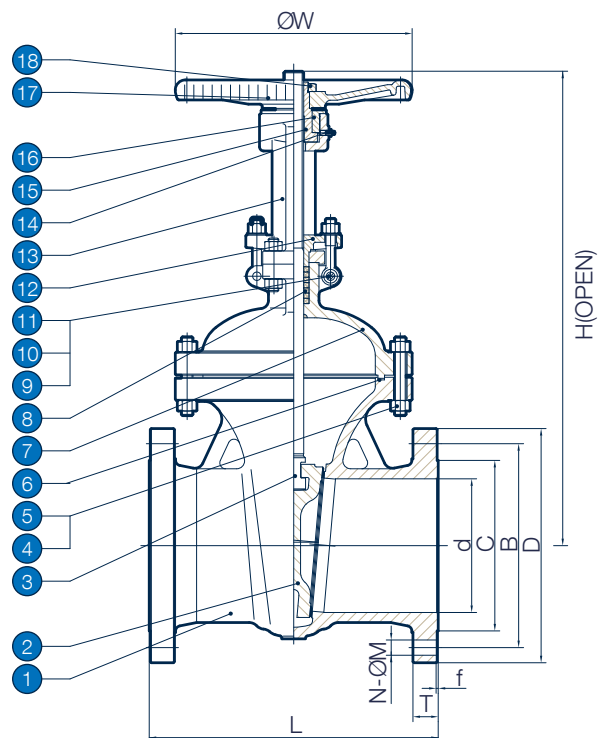

Dimensions (mm):

SIZE		d	D	B	C	W	L	H	T	f	N	M
DN	NPS											
200	8	200	360	310	278	350	400	985	30	3	12	26
250	10	250	425	370	335	400	450	1114	32	3	12	30
300	12	300	485	430	395	450	500	1340	34	4	16	30
350	14	350	555	490	450	500	550	1550	38	4	16	33
400	16	400	620	550	505	550	600	1700	40	4	16	36
500	20	500	730	660	615	700	700	2110	44	4	20	36
600	24	600	845	770	720	700	800	2540	46	5	20	39

GATE VALVE

Cast Steel OS&Y to DIN
PN25, DN700-DN1000

KSD-GTF PN25-F5

» Features

Cast steel body construction providing liberal strength to meet most conditions
Integral yoke & bonnet; Outside screw & yoke, bolted bonnet
Single flexible wedge disc compensates for deformation of body due to pipe stresses
Seal welded seat ring eliminates leak path behind rings and for long trouble-free service
Available in flanged end connection; butt weld end also available

» Body Material

DIN 17245 GS-C25

» Standards

Basic design to DIN 3352
Face-to-Face acc. to DIN 3202-F5
Flange Dimensions acc. to DIN 2544
Inspection & test according to EN 12266-1

» Temperature Range

-20°C to 425°C (-4°F to 800°F)

» Note

For non-horizontal installation, please ensure to consult with us separately, as special request must be generated to ensure proper function.

Materials List:

NO	PART NAME	MATERIAL
1	BODY	DIN 17245 GS-C25 + 13Cr
2	WEDGE	DIN 17245 GS-C25 + 13Cr
3	STEM	ASTM A182 F6a
4	BONNET BOLT	ASTM A193 B7
5	BONNET NUT	ASTM A194 2H
6	GASKET	SS304+FLEXIBLE GRAPHITE
7	BONNET	DIN 17245 GS-C25
8	STEM PACKING	FLEXIBLE GRAPHITE
9	GLAND	ASTM A182 F6a
10	GLAND FLANGE	DIN 17245 GS-C25
11	BOLT	ASTM A193 B7
12	NUT	ASTM A194 2H
13	YOKE BOLT	ASTM A193 B7
14	YOKE NUT	ASTM A194 2H
15	YOKE	DIN 17245 GS-C25
16	STEM NUT	ASTM A439 D2
17	GEAR BOX	COMPONENTS

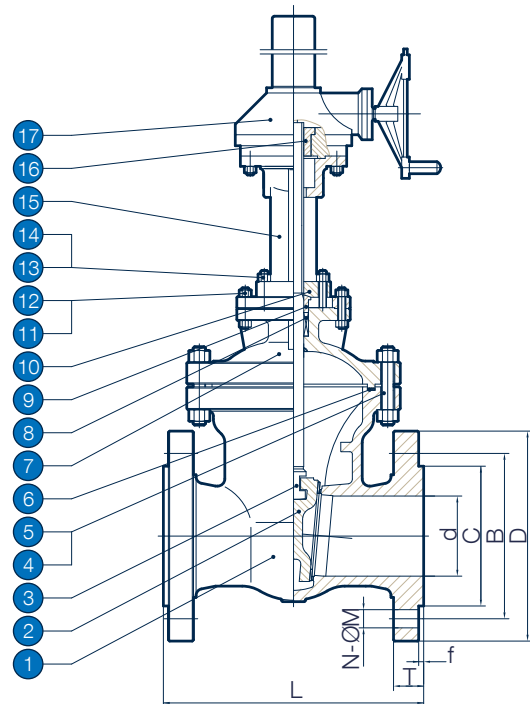

Dimensions (mm):

SIZE		d	D	B	C	L	T	f	N	M
DN	NPS									
700	28	700	960	875	820	900	50	5	24	42
800	32	800	1085	990	930	1000	54	5	24	48
900	36	900	1185	1090	1030	1100	58	5	28	48
1000	40	1000	1320	1210	1140	1200	62	5	28	56