

GATE VALVE

Cast Steel OS&Y to DIN
PN16, DN40-DN200

KSD-GTF PN16-F4

» Features

Cast steel body construction providing liberal strength to meet most conditions
Integral yoke & bonnet; Outside screw & yoke, bolted bonnet
Single flexible wedge disc compensates for deformation of body due to pipe stresses
Seal welded seat ring eliminates leak path behind rings and for long trouble-free service
Available in flanged end connection; butt weld end also available

» Body Material

DIN 17245 GS-C25

» Standards

Basic design to DIN 3352
Face-to-Face acc. to DIN 3202-F4
Flange Dimensions acc. to DIN 2543
Inspection & test according to EN 12266-1

» Temperature Range

-20°C to 425°C (-4°F to 800°F)

» Note

For non-horizontal installation, please ensure to consult with us separately, as special request must be generated to ensure proper function.

Materials List:

NO	PART NAME	MATERIAL
1	BODY	DIN 17245 GS-C25 + 13Cr
2	WEDGE	DIN 17245 GS-C25 + 13Cr
3	STEM	ASTM A182 F6a
4	BONNET BOLT	ASTM A193 B7
5	BONNET NUT	ASTM A194 2H
6	GASKET	SS304+FLEXIBLE GRAPHITE
7	BONNET	DIN 17245 GS-C25
8	STEM PACKING	FLEXIBLE GRAPHITE
9	GLAND EYEBOLT	ASTM A193 B7
10	GLAND NUT	ASTM A194 2H
11	PIN	AISI 1025
12	GLAND FLANGE	DIN 17245 GS-C25
13	NIPPLE	COPPER ALLOY
14	STEM NUT	ASTM A439 D2
15	RETAINING NUT	AISI 1025
16	HANDWHEEL	DUCTILE IRON
17	LOCK NUT	AISI 1025

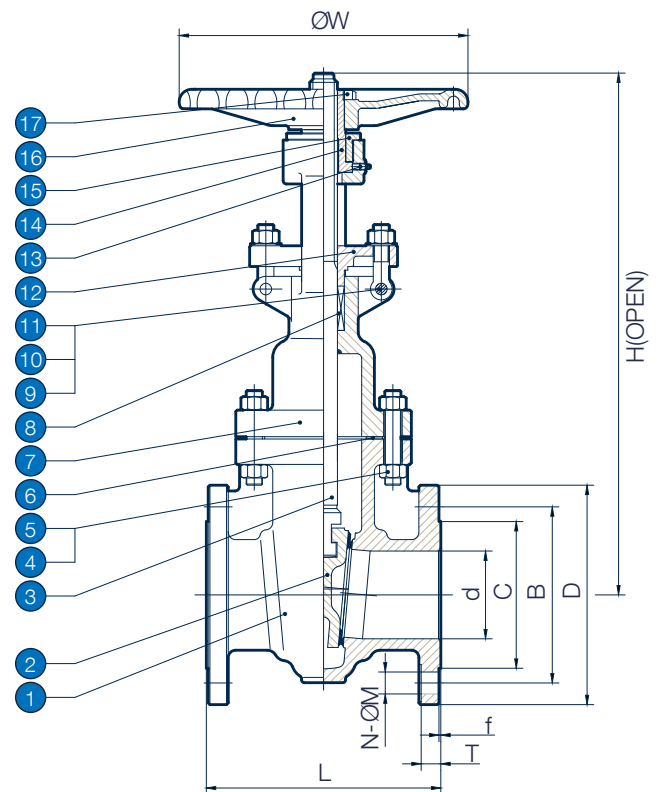

Dimensions (mm):

SIZE		d	D	B	C	W	L	H	T	f	N	M
DN	NPS											
40	1½	40	150	110	88	180	140	365	18	3	4	18
50	2	50	165	125	102	200	150	410	18	3	4	18
65	2½	65	185	145	122	220	170	462	18	3	4	18
80	3	80	200	160	138	250	180	518	20	3	8	18
100	4	100	220	180	158	280	190	605	20	3	8	18
125	5	125	250	210	188	300	200	678	22	3	8	18
150	6	150	285	240	212	300	210	798	22	3	8	22
200	8	200	340	295	268	350	230	985	24	3	12	22

GATE VALVE

Cast Steel OS&Y to DIN
PN16, DN250-DN600

KSD-GTF PN16-F4

» Features

Cast steel body construction providing liberal strength to meet most conditions
Integral yoke & bonnet; Outside screw & yoke, bolted bonnet
Single flexible wedge disc compensates for deformation of body due to pipe stresses
Seal welded seat ring eliminates leak path behind rings and for long trouble-free service
Available in flanged end connection; butt weld end also available

» Body Material

DIN 17245 GS-C25

» Standards

Basic design to DIN 3352
Face-to-Face acc. to DIN 3202-F4
Flange Dimensions acc. to DIN 2543
Inspection & test according to EN 12266-1

» Temperature Range

-20°C to 425°C (-4°F to 800°F)

» Note

For non-horizontal installation, please ensure to consult with us separately, as special request must be generated to ensure proper function.

Materials List:

NO	PART NAME	MATERIAL
1	BODY	DIN 17245 GS-C25 + 13Cr
2	WEDGE	DIN 17245 GS-C25 + 13Cr
3	STEM	ASTM A182 F6a
4	BONNET BOLT	ASTM A193 B7
5	BONNET NUT	ASTM A194 2H
6	GASKET	SS304+FLEXIBLE GRAPHITE
7	BONNET	DIN 17245 GS-C25
8	STEM PACKING	FLEXIBLE GRAPHITE
9	GLAND EYEBOLT	ASTM A193 B7
10	GLAND NUT	ASTM A194 2H
11	PIN	AISI 1025
12	YOKE BOLT	ASTM A193 B7
13	YOKE NUT	ASTM A194 2H
14	GLAND FLANGE	DIN 17245 GS-C25
15	YOKE	DIN 17245 GS-C25
16	BEARINGS	ALLOY STEEL
17	NIPPLE	COPPER ALLOY
18	STEM NUT	ASTM A439 D2
19	RETAINING NUT	AISI 1025
20	HANDWHEEL	DUCTILE IRON
21	LOCK NUT	AISI 1025

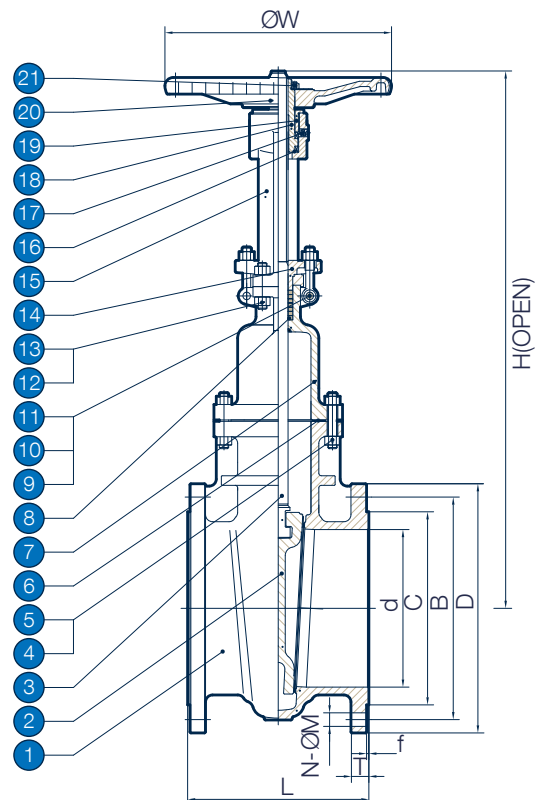

Dimensions (mm):

SIZE		d	D	B	C	W	L	H	T	f	N	M
DN	NPS											
250	10	250	405	355	320	400	250	1114	26	3	12	26
300	12	300	460	410	378	450	270	1340	28	4	12	26
350	14	350	520	470	438	500	290	1550	30	4	16	26
400	16	400	580	525	490	550	310	1700	32	4	16	30
500	20	500	715	650	610	700	350	2110	36	4	20	33
600	24	600	840	770	725	700	390	2540	40	5	20	36

GATE VALVE

Cast Steel OS&Y to DIN
PN16, DN700-DN1000

KSD-GTF PN16-F4

» Features

Cast steel body construction providing liberal strength to meet most conditions
Integral yoke & bonnet; Outside screw & yoke, bolted bonnet
Single flexible wedge disc compensates for deformation of body due to pipe stresses
Seal welded seat ring eliminates leak path behind rings and for long trouble-free service
Available in flanged end connection; butt weld end also available

» Body Material

DIN 17245 GS-C25

» Standards

Basic design to DIN 3352
Face-to-Face acc. to DIN 3202-F4
Flange Dimensions acc. to DIN 2543
Inspection & test according to EN 12266-1

» Temperature Range

-20°C to 425°C (-4°F to 800°F)

» Note

For non-horizontal installation, please ensure to consult with us separately, as special request must be generated to ensure proper function.

Materials List:

NO	PART NAME	MATERIAL
1	BODY	DIN 17245 GS-C25 + 13Cr
2	WEDGE	DIN 17245 GS-C25 + 13Cr
3	STEM	ASTM A182 F6a
4	BONNET BOLT	ASTM A193 B7
5	BONNET NUT	ASTM A194 2H
6	GASKET	SS304+FLEXIBLE GRAPHITE
7	BONNET	DIN 17245 GS-C25
8	STEM PACKING	FLEXIBLE GRAPHITE
9	GLAND	ASTM A182 F6a
10	GLAND FLANGE	DIN 17245 GS-C25
11	BOLT	ASTM A193 B7
12	NUT	ASTM A194 2H
13	YOKE BOLT	ASTM A193 B7
14	YOKE NUT	ASTM A194 2H
15	YOKE	DIN 17245 GS-C25
16	STEM NUT	ASTM A439 D2
17	GEAR BOX	COMPONENTS

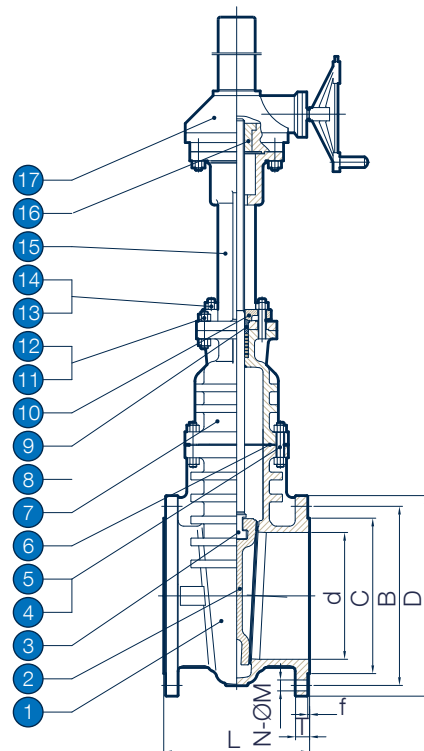

Dimensions (mm):

SIZE		d	D	B	C	L	T	f	N	M
DN	NPS									
700	28	700	910	840	795	430	42	5	24	36
800	32	800	1025	950	900	470	42	5	24	39
900	36	900	1125	1050	1000	510	44	5	28	39
1000	40	1000	1255	1170	1115	550	46	5	28	42