

CHECK VALVE

Wafer Type Spring Load Check Valve
PN16/PN40, DN15~DN300

MODEL: KRD-SWS

» **Body Material**

DIN 1.4408

» **Size Range**

1/2" - 12" (DN15~DN300)

» **Pressure Rating**

DIN PN16/PN40

» **Standards**

Inspection acc. to EN12266-1

» **Face to Face**

EN 558 Series 49 (DIN 3202 K4)

» **Temperature Range**

Metal seat : -20°C to 260°C

Soft seat with VITON O-ring : -20°C to 180°C

NBR O-ring : -20°C to 80°C

Materials List:

NO	PART NAME	MATERIAL
1	BODY	1.4408/CF8M/1.4308/CF8
2	DISC	SS316/SS304
3	CAP	SS316/SS304
4	SPRING	SS316/SS304
5	O-RING (Optional)*	NBR/VITON

* Not available for DN15

Dimensions (mm):

SIZE		d	B	D	L
IN	DN				
1/2"	15	12.5	44.6	54	16
3/4"	20	20	54	62	19
1"	25	25	65	73	22
1 1/4"	32	32	78	83	28
1 1/2"	40	38	88	93	31.5
2"	50	49	101.6	107	40
2 1/2"	65	64	120.4	126.5	46
3"	80	78	133	144.2	49
4"	100	98	164	171.4	60
5"	125	110	-	190	90
6"	150	130	-	220	105
8"	200	200	-	270	140
10"	250	249	-	345	150**
12"	300	295	-	410	160**

** Manufacturer's length

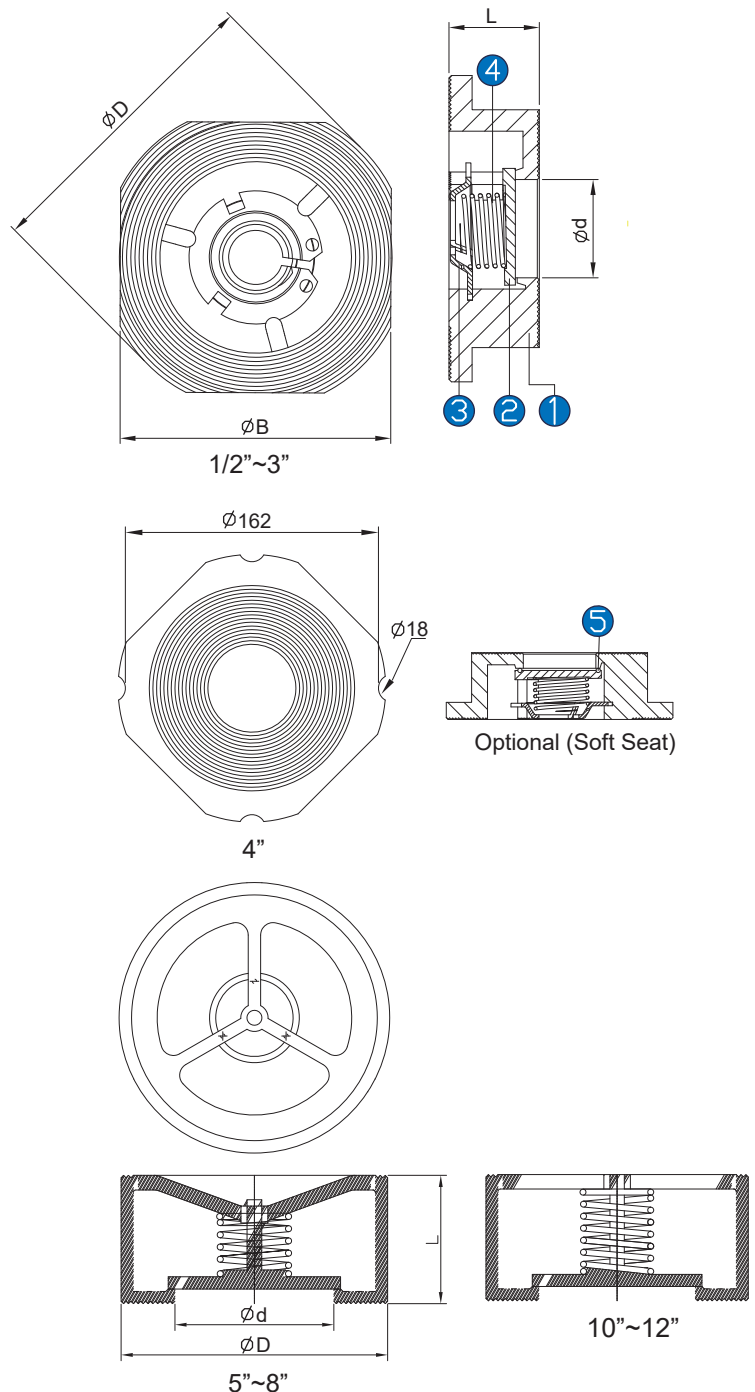

CHECK VALVE

Wafer Type Spring Load Check Valve
PN16/PN40, DN15~DN300

MODEL: KRD-SWS

Opening Pressure Standard In mbar:

SIZE		FLOW DIRECTION		
IN	DN	↑	↓	→
1/2"	15	25	21	23
3/4"	20	25	21	23
1"	25	25	21	23
1 1/4"	32	27	21	24
1 1/2"	40	29	21	25
2"	50	29	21	25
2 1/2"	65	31	21	25
3"	80	32	21	26
4"	100	33	21	27

