

CHECK VALVE TYPE 483

CHARACTERISTIC:

Diameter	-	15 -125 mm;
Pressure	-	400 bar;
Temperature	-	up to 670°C;
Medium	-	water, steam and other non-toxic, non aggressive liquid and gas media.

VERSIONS:

type / ends / body material / disc and disc ring / others

Example: 483 / --- / --- / --- / ---

Example: 483 / K / U / --- / ---

Ends	Sign	Body material	Sign	Disc and disc ring	Sign	Others	Sign
Standard-butt weld ends	---	(P250GH) C 22.8	---	Standard	---	-----	---
Socket weld	SW	16Mo3	U	Stellite ring	L		
Flange by DIN or ANSI,	K	13CrMo4-5	A				
		11CrMo9-10	B				
		14MoV6-3	C				
		X10CrMoVNb9-1	E				

APPLICATION:

The check valve is designed to keep pipeline safe from returning the medium.

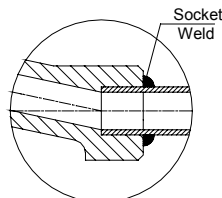
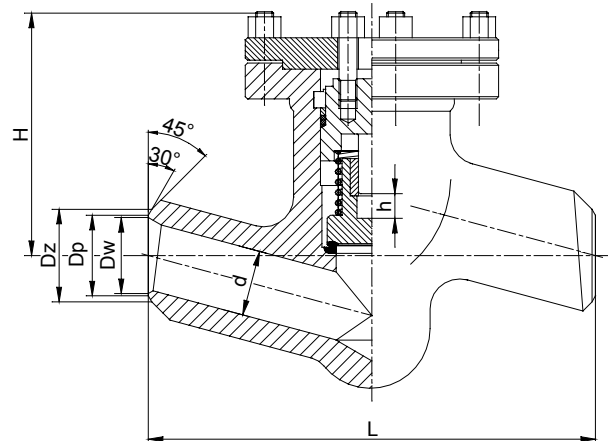
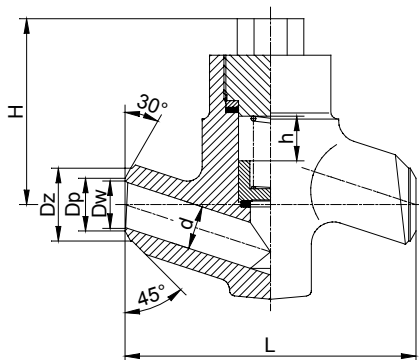

MATERIALS:

Versions	Standard	U	A	B	C	E
Parts	T _{MAX} 450°C	T _{MAX} 530°C	T _{MAX} 560°C	T _{MAX} 600°C	T _{MAX} 570°C	T _{MAX} 670°C
Body, bonnet	(P250GH) C22.8 (1.0460)	16Mo3 (1.5415)	13CrMo4-5 (1.7335)	11CrMo9-10 (1.7383)	14MoV6-3 (1.7715)	X10CrMoVNb9-1 (1.4903)
Seat ring	BT9 or G 18 8 Mn (1.4370) or Stellite					
Disc	X20Cr13 (1.4021) , P245GH (1.0352)					X10CrMoVNb9-1
Disc ring	G 18 8 Mn (1.4370) or Stellite					
Spring	51CrV4 (1.2241)					
Gasket	Grafit + austenite					
Bonnet DN > 32	P265GH (1.0425)					

Special materials on request; modifications reserved.

DIMENSIONS:

Standard - BW						H	h
DN	d	Dz	Dw	L	Weight		
15	14	28	17	160	4,00	135	15
20	20	35	21,5	160	4,00	140	15
25	24	44	29	160	4,00	140	15
32	30	50	33	300	15,00	245	27
40	38	62	40	300	15,00	245	27
50	44	77	49,5	300	15,00	245	27
65	62	91	62	340	26,50	270	30
80	76	117	81	380	55,50	320	40
100	92	144	102	430	71,00	390	55
125	112	172	126,5	500	91,00	420	65

Dimensions in mm; modifications reserved.

TECHNICAL DATA:

Body material	PN	Maximal working pressure at working temperature															
		20°C	100°C	150°C	200°C	250°C	300°C	350°C	400°C	450°C	480°C	500°C	520°C	530°C	540°C	560°C	570°C
(P250GH)C 22.8 (1.0460)	400	400,0	400,0	400,0	400,0	400,0	358,0	310,0	262,0	165,0	-	-	-	-	-	-	-
16Mo3 (1.5415)	400	400,0	400,0	400,0	400,0	400,0	400,0	400,0	382,0	369,0	222,0	176,0	141,0	112,0	-	-	-
13CrMo4-5 (1.7335)	400	400,0	400,0	400,0	400,0	400,0	400,0	400,0	400,0	400,0	327,0	276,0	224,0	186,0	146,0	95,0	79,0
14MoV6-3 (1.7715)	400	400,0	400,0	400,0	400,0	400,0	400,0	400,0	400,0	400,0	400,0	355,0	312,0	269,0	205,0	174,0	-
11CrMo9-10 (1.7383)	400	400,0	400,0	400,0	400,0	400,0	400,0	400,0	400,0	393,0	379,0	322,0	246,0	215,0	186,0	138,0	122,0
Body material	PN	Maximal working pressure at working temperature															
		20°C	530°C	540°C	550°C	560°C	570°C	580°C	590°C	600°C	610°C	620°C	630°C	640°C	650°C	660°C	670°C
X10CrMoVNb9-1 (1.4903)	400	400,0	400,0	400,0	396,0	358,0	319,0	286,0	253,0	224,0	198,0	174,0	155,0	134,0	117,0	100,0	86,0

MOUNTING AND OPERATING:

The valve can only be mounted and operated by skilled, properly trained and qualified personnel. Incorrect assembly or operation of the valve may have substantial impact on the entire system such as fluid leakage, reduction in system's function etc.

Before a valve is installed the pipeline must be clean from any mechanical impurities. The compatibility of critical parameters of the flow must be checked with the parameters of the valve. Stop globe valve can be mounted to a pipe-line in any position. The direction of flow should only comply with the arrow marked on the body. The valve should be operated strictly with its assign. In order to provide valve's reliability the following suggestions must be observed:

- medium flowing through the valve is supposed to be clean out of any mechanical impurities;
- the valve must be protected from any mechanical damages during its work;
- nominal parameters marked on the valve must be observed.