

CHECK VALVE ACID-PROOF TYPE ZZA250

CHARACTERISTIC:

- Diameter - 15 -125 mm;
- Pressure - 250 bar
- Temperature - up to 250°C for acids, bases and other aggressive media;
- up to 560°C for non-toxic media; (with PTFE sealing up to 200°C);
- Medium - acids, liquors, water, steam and other non-toxic and non aggressive liquid and gas media, engine fuel.

VERSIONS:

type - body material / ends / disc and disc ring / others

Example: ZZA250 / --- / --- / ---

Example: ZZB250 / S / P / ---

Type - body material	Sign	Ends	Sign	Disc and disc ring	Sign	Others	Sign
X6CrNi18-10 or GX5CrNi19-10	ZZA250	Standard - flanged	---	Standard	---	-----	---
X2CrNiMo17-12-2 or GX5CrNiMo19-11-2	ZZB250	Butt weld ends	S	PTFE ring	P		
		Socket weld	SW	NBR ring	N		
		Threaded	G				

APPLICATION:

The check valves are designed to keep pipeline safe from returning the medium.

DN 15 ÷ 25

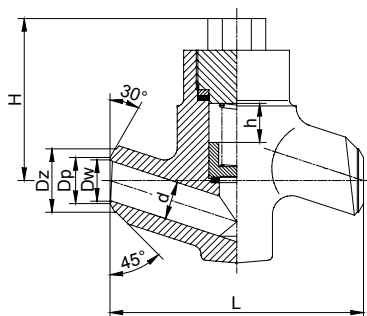

"K"

DN 32 ÷ 125

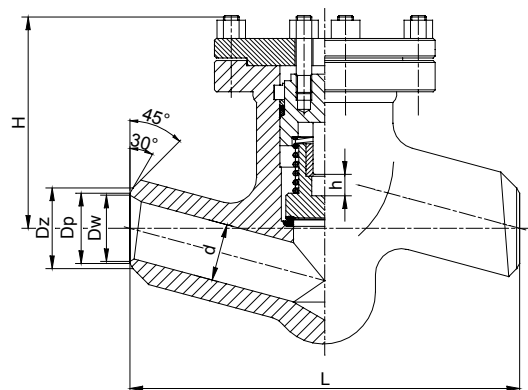

"K"

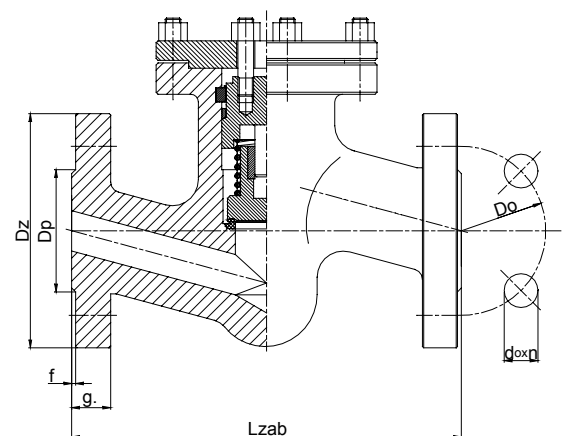
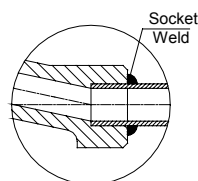
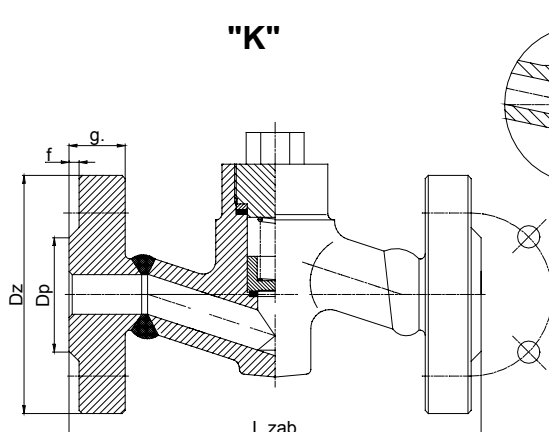

MATERIALS:

Versions	ZZA250	ZZB250	ZZA250	ZZB250
Parts	DN 15 - 50		DN 65 - 125	
Body, bonnet	X6CrNiTi18-10 (1.4541)	X2CrNiMo17-12-2 (1.4404)	GX5CrNi19-10 (1.4308)	GX5CrNiMo19-11-2 (1.4408)
Disc	X6CrNiTi18-10 (1.4541)	X2CrNiMo17-12-2 (1.4404)	X6CrNiTi18-10 (1.4541)	X2CrNiMo17-12-2 (1.4404)
Spring	X6CrNiTi18-10 (1.4541)			
Gasket	Grafit			

Special materials on request; modifications reserved.

DIMENSIONS:

Standard – butt weld ends						H	h	Flanged - "K"									
DN	d	Dz	Dw	L	Weight			DN	Dz	Dp	Do	do	n	L _{zab}	g.	f	Weight
15	14	22	16	160	4,00	235	15	15	130	45	90	18	4	230	26	2	8,70
20	20	28	19,5	160	4,00	240	15	20	150	58	105	22	4	260	28	2	11,30
25	24	35	26,5	160	4,00	240	15	25	150	68	105	22	4	260	28	2	13,30
32	32	44	32,5	300	15,00	365	27	32	-	-	-	-	-	-	-	-	-
40	38	50	38,5	300	15,00	365	27	40	185	88	135	26	4	300	34	3	30,20
50	48	62	45	300	15,00	365	27	50	200	102	150	26	8	350	38	3	32,00
65	62	77	59,5	340	26,50	450	30	65	230	122	180	26	8	400	42	3	57,80
80	76	117	93	380	55,50	580	40	80	255	138	200	30	8	450	46	3	93,00
100	92	144	116,5	430	71,00	620	55	100	300	162	235	33	8	520	54	3	138,50
125	112	172	138,5	500	91,00	670	65	125	340	188	275	33	12	600	60	3	186,90

Dimensions in mm; modifications reserved.

TECHNICAL DATA:

Body material	Medium	PN	Nominal working pressure at working temperature															
			20°C	100°C	150°C	200°C	250°C	300°C	350°C	400°C	450°C	480°C	500°C	510°C	520°C	530°C	540°C	550°C
X6CrNiTi18-10 (1.4541)	Aggressive media	250	250	248	233	221	211	-	-	-	-	-	-	-	-	-	-	-
GX5CrNi19-10 (1.4308)		250	238	191	170	149	140	-	-	-	-	-	-	-	-	-	-	-
X6CrNiTi18-10 (1.4541)	Non Aggressive media	250	250	248	233	221	211	199	192	186	182	180	177	177	176	176	175	169
GX5CrNi19-10 (1.4308)		250	238	191	170	149	140	131	122	113	104	98	95	-	-	-	-	-

MOUNTING AND OPERATING:

The valve can only be mounted and operated by skilled, properly trained and qualified personnel. Incorrect assembly or operation of the valve may have substantial impact on the entire system such as fluid leakage, reduction in system's function etc.

Before a valve is installed the pipeline must be clean from any mechanical impurities. The compatibility of critical parameters of the flow must be checked with the parameters of the valve. Check valve can be mounted to a pipe-line in any position. The direction of flow should only comply with the arrow marked on the body. The valve should be operated strictly with its assign. In order to provide valve's reliability the following suggestions must be observed:

- medium flowing through the valve is supposed to be clean out of any mechanical impurities;
- the valve must be protected from any mechanical damages during its work;
- nominal parameters marked on the valve must be observed.