

# Y-TYPE CHECK VALVE TYPE 337

## CHARACTERISTIC:

- Diameter - 15 -200 mm;
- Pressure - 40 bar (flanges may be drilled for PN 6, 10, 16, 25 bar);
- Temperature - up to 530°C (with PTFE sealing up to  $\leq 200^\circ\text{C}$ );
- Medium - water, steam and other non-toxic, non aggressive liquid and gas media and engine fuel, sea water.

## VERSIONS:

**type / ends / body material / disc and disc ring / others**

**Example: 337 / --- / --- / --- / ---**

**Example: 337 / S / U / P / WM**

Ends	Sign	Body material	Sign	Disc and disc ring	Sign	Others	Sign
Standard - flanged	---	(P250GH) C 22.8 or GP240GH	---	Standard	---	----	---
Butt weld ends	<b>S</b>			PTFE ring	<b>P</b>	Sea version	<b>WM</b>
Socket weld	<b>SW</b>	16Mo3 or G20Mo5	<b>U</b>	NBR ring	<b>N</b>		
Threaded	<b>G</b>			STELLIT ring	<b>L</b>		

## APPLICATION:

The check valve is designed to keep pipeline safe from returning the medium.

**DN 15 - 50**

**DN 65 - 200**

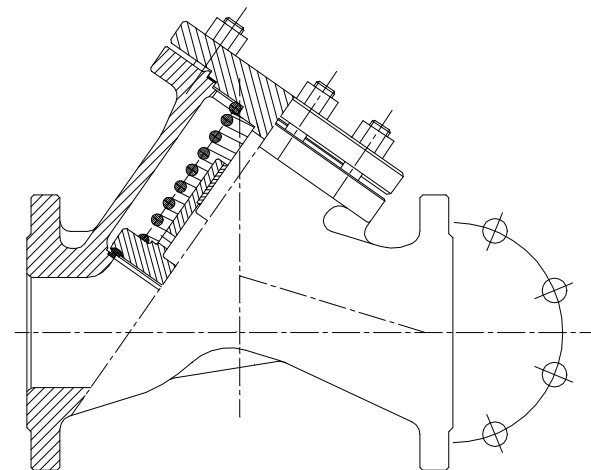
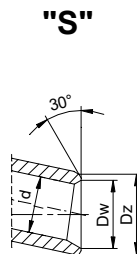
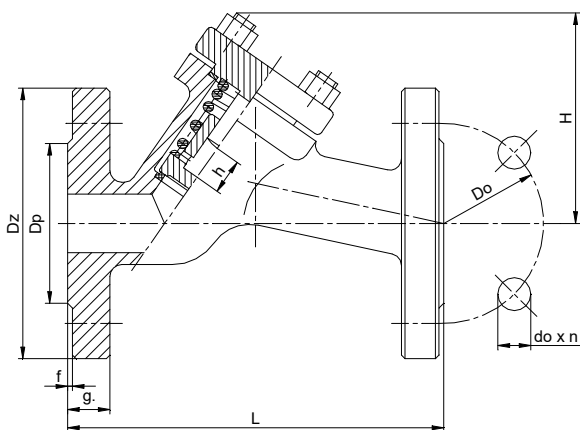

$T_{\text{MAX}} 200^\circ\text{C}$

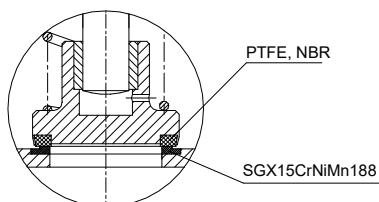

**"G"**

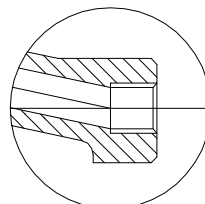

**"SW"**

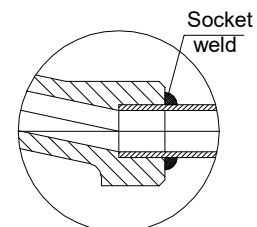

## MATERIALS:

Versions	Standard	U	Standard	U
Parts	T <sub>MAX</sub> 450°C	T <sub>MAX</sub> 530°C	T <sub>MAX</sub> 450°C	T <sub>MAX</sub> 500°C
	DN 15 - 50		DN 65 - 200	
Body, bonnet	(P250GH) C22.8 (1.0460)	16Mo3 (1.5415)	GP240GH (1.0619)	G20Mo5 (1.5419)
Seat ring DN15-25	X17CrNi16-2			
Seat ring	G 18 8 Mn (1.4370) or Stellite, or CW306G			
Disc	X30Cr13 (1.4028), X17CrNi16-2 (1.4057), P245GH (1.0352), CW306G, X6CrNiTi18-10 (1.4541)			
Disc ring	G 18 8 Mn (1.4370) lub Stellite, CW306G, PTFE, NBR			
Spring	51CrV4 (1.2241)			
Gasket	Grafit			

Special materials on request; modifications reserved.

## DIMENSIONS:

DN	Standard - flanged															With butt weld ends			
	PN 40										PN 16					Dz	Dw	Weight	
	Dz	Dp	Do	do	n	L	g.	f	H	h	Weight	Dz	Dp	Do	do				n
15	95	45	65	14	4	130	16	2	90	10	2,20	95	45	65	14	4	22	17	1,40
20	105	58	75	14	4	150	18	2	97	10	2,60	105	58	75	14	4	28	22	1,50
25	115	68	85	14	4	160	18	2	97	10	3,00	115	68	85	14	4	35	28,5	1,60
32	140	78	100	18	4	180	18	2	124	15	6,00	140	78	100	18	4	44	37	2,06
40	150	88	110	18	4	200	18	3	134	17	8,00	150	88	110	18	4	50	43	3,54
50	165	102	125	18	4	230	20	3	145	21	9,50	165	102	125	18	4	62	54	3,70
65	185	122	145	18	8	290	22	3	180	22	15,50	185	122	145	18	4	77	69	7,82
80	200	138	160	18	8	310	24	3	215	26	24,00	200	138	160	18	8	91	81	14,55
100	235	162	190	22	8	350	24	3	235	32	37,00	220	158	180	18	8	117	104	24,56
125	270	188	220	26	8	400	26	3	280	40	49,00	250	184	210	18	8	144	130,5	31,99
150	300	218	250	26	8	480	28	3	320	44	81,00	285	212	240	22	8	172	156,5	59,89
200	375	285	320	30	12	600	34	3	445	60	135,00	340	268	295	22	12	223	204,5	96,68

Dimensions in mm; modifications reserved.

## TECHNICAL DATA:

Body material	PN	Maximal working pressure at working temperature																
		20°C	100°C	150°C	200°C	250°C	300°C	350°C	400°C	450°C	480°C	500°C	510°C	520°C	530°C	540°C	550°C	560°C
(P250GH)C 22.8 (1.0460)	40	bar																
		40,0	40,0	40,0	36,2	32,4	28,6	24,8	20,9	13,1	-	-	-	-	-	-	-	-
16Mo3 (1.5415)	40	40,0	40,0	40,0	40,0	39,0	34,3	32,4	30,5	29,5	22,4	17,7	14,5	11,2	9,0	-	-	-
GP240GH (1.0619)	40	40,0	31,6	28,9	26,3	24,1	20,3	25,7	19,5	12,5	-	-	-	-	-	-	-	-
G20Mo5 (1.5419)	40	40,0	33,2	30,9	28,6	26,7	24,8	23,3	22,5	21,8	16,4	12,8	-	-	-	-	-	-

## MOUNTING AND OPERATING:

*The valve can only be mounted and operated by skilled, properly trained and qualified personnel. Incorrect assembly or operation of the valve may have substantial impact on the entire system such as fluid leakage, reduction in system's function etc.*

Before a valve is installed the pipeline must be clean from any mechanical impurities. The compatibility of critical parameters of the flow must be checked with the parameters of the valve. Check valve can be mounted to a pipe-line in any position. The direction of flow should only comply with the arrow marked on the body. The valve should be operated strictly with its assign. In order to provide valve's reliability the following suggestions must be observed:

- medium flowing through the valve is supposed to be clean out of any mechanical impurities;
- the valve must be protected from any mechanical damages during its work;
- nominal parameters marked on the valve must be observed.