

BUTTERFLY VALVE WAFER TYPE of carbon steel



Description

Edition 23-07-2015

Wafer type butterfly valve 311 (310 – 312) series is used in industrial pipelines for demanding on-off and regulating tasks as well as in district heating, district cooling, petrochemical, oil industry, pulp and paper industry and power production. It is tight to both directions of flow.

The body of valve is full bore and material is cast carbon steel. The eccentric disc and shaft are stainless steel. The shaft packing box is a combination of graphite rings and O-rings which are possible to tighten while in pipeline and are also replaceable. Seal materials depend on media.

Nominal dimensions:	DN 80 – 800	
Nominal pressure	PN 25 bar	
Disk seal alternatives	Stainless steel (CS)	PTFE+C (TS)
Closing pressure (ΔP)	16 bar – standard 25 bar - option	16 bar – standard 25 bar - option
Tightness class ISO 5208, EN 12266-1	RATE B - standard, RATE A - option	RATE A
Working temperature of liquid media * (version for steam also available)	+260°C -40°C	+180°C -40°C
Connection **	Between neck-type flanges: EN1092-1 Type 11, Facing Type B, PN25, PN16, PN10, ANSI CLASS 150, or GOST12821 (must be specified in order)	
Safety	<p>Conform to the requirements of the Council Directive 97/23/EC on Pressure Equipment, marking: Class: gas, group 1.</p> <p>Explosion-proof design is available as per special order. Marking in accordance to ATEX Directive 94/9/EC: group II 2 GD, protection concept of non-electrical components: c T6.</p>	



*) Wider temperature range is available.

**) For the valves DN450 and higher the design pressure (PN10, PN16, PN25) of flanges on the pipeline must be specified in order.

Consult factory for details.

BUTTERFLY VALVE

wafer type

Exploded view

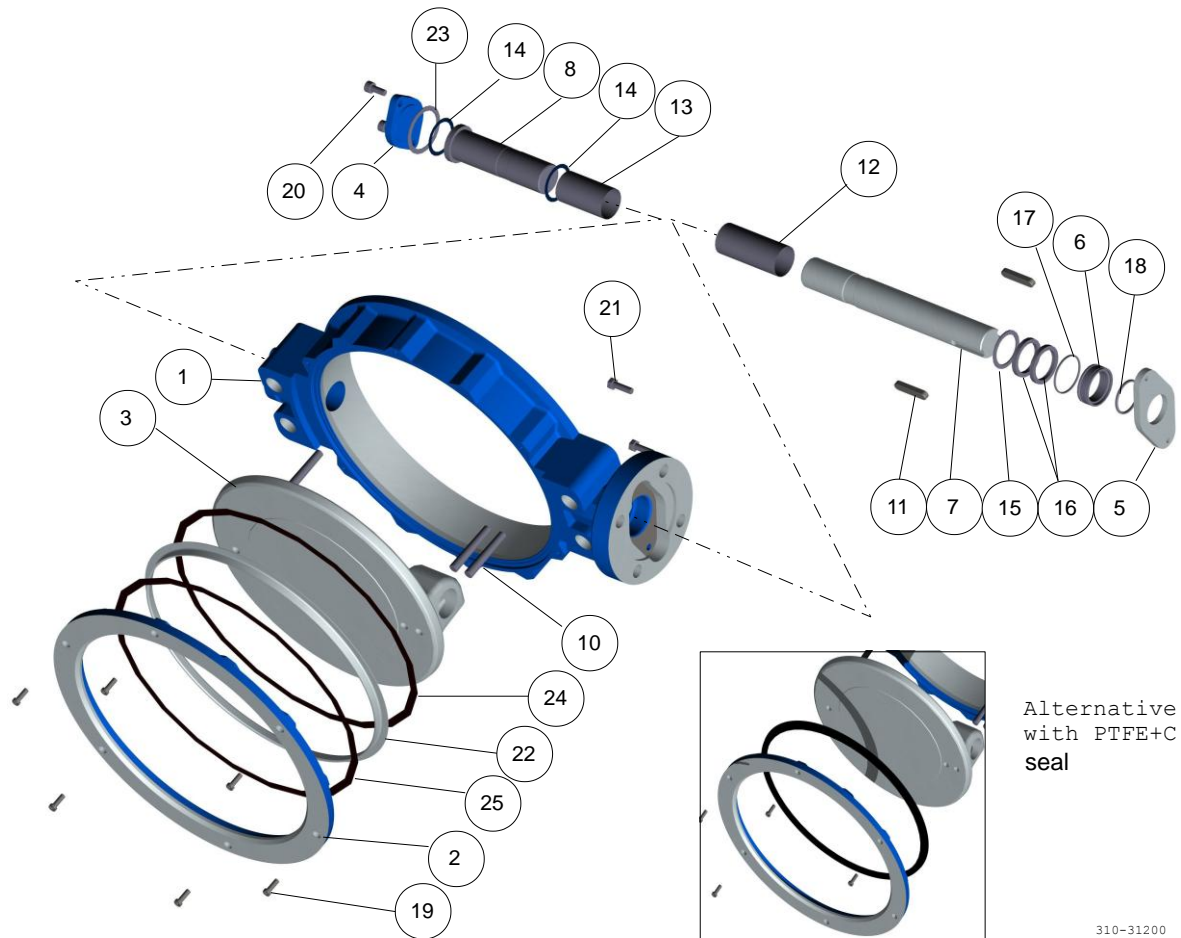

Parts list and standard materials

Part	Material		
1	Body	Cast carbon steel EN10213 GP240GH / ASTM A216 WCB	
2	Counter flange	Carbon steel EN10028-2 P265GH	
3	Disk	Stainless steel EN10213 1.4408, ASTM A351 CF8M, SS2324	
4	Subshaft cover	Stainless steel EN10216-5 1.4436 / 1.4404	
5	Gland	Stainless steel EN10216-5 1.4436 / 1.4404	
6	Shaft seal bushing	Stainless steel EN10216-5 1.4404	
7	Main shaft	Stainless steel EN10088-3 1.4460 / 1.4418+QT900	
8	Subshaft	Stainless steel EN10088-3 1.4460 / 1.4418+QT900	
10	Pins	Stainless steel EN10088-3 1.4462 / 1.4418+QT900	
11	Key	Carbon steel 1.0503 DIN 6885A	
12	Stem bearing	PTFE on stainless steel net	
13	Subshaft bearing	PTFE on stainless steel net	
14	Bearing plate	PTFE on stainless steel net	
15	Back-up-ring	Stainless steel EN10216-5 1.4404	
16	Box packing	Graphite	
17,18	O-ring	FPM / EPDM	Not fitted in steam version
19	Socket screw	Stainless steel ISO 3506 A4-80	
20	Socket screw	Stainless steel ISO 3506 A4-80	
21	Hexagonal screw	Stainless steel ISO 3506 A4-80	
22	Seat ring	Hard chrome plated stainless steel AISI 316L or PTFE+C	Special material by request
23	Bottom cover gasket	Carbon Fibre / Graphite	Graphite for steam version
24, 25	Shim	Carbon Fibre / Graphite	Graphite for steam version

BUTTERFLY VALVE

wafer type

Dimensions

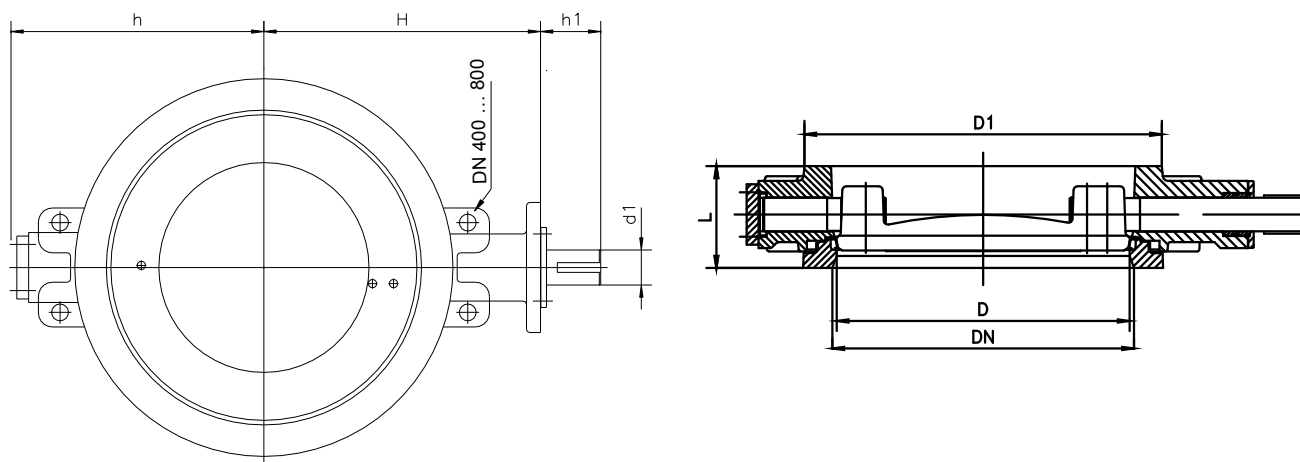

DN	L**			D1	D	h	H	h1	d1	Flange ISO5211	Weight, kg	Weight with manual gear, kg		
	310	311	312								311 Bare shaft	310	311	312
80	49	46	64	138	72	114	144	45	15	F07	6.5	7,9	7,6	9,1
100	56	52	64	158	89	131	168	52	20	F07	8	9,5	9,1	10,4
125	64	56	70	188	113	143	179	52	20	F07	9.8	12,0	10,9	12,9
150	70	56	76	212	137	160	199	58	25	F10	14.9	19,1	16,9	20,1
200	71	60	89	268	187	200	224	58	25	F12	25	37,1*	34,8*	41,4*
250	76	68	114	320	238	232	269	63	30	F12	30	42,0*	39,8*	52,7*
300	83	78	114	370	286	275	308	69	35	F14	40.5	59,3*	57,8*	69,9*
350	92	78	127	430	337	303	335	75	40	F14	52	75,3*	69,3*	90,7*
400	–	102	140	482	386	333	380	86	50	F16	86.5	–	122,5*	141,9*
450	–	114	152	530	437	358	408	86	50	F16	117	–	153,0*	172,1*
500	–	127	152	585	483	388	458	103	60	F16	160	–	196,0*	212,1*
600	–	154	178	685	582	448	530	119	70	F25	280	–	354,0*	372,6*
700	–	165	229	785	682	498	602	119	70	F30	318	–	392,0*	453,3*
800	–	190	241	885	775	566	650	125	90	F30	454	–	539,0*	588,7*

*) weight without hand wheel

***) Face-to-face length according to ISO 5752. EN 558-1 Series 20 DIN3202 K1 (series 311)
 EN 558-1 Series 25 DIN3202 K2 (series 310)
 EN 558-1 Series 16 DIN3202 K3 (series 312)

Operation

Valves can be equipped with an actuator to your specification.

- bare shaft (not recommended),
- manual gear,
- electric actuator,
- universal actuator MF,
- pneumatic or hydraulic actuator.

BUTTERFLY VALVE

wafer type

Operation torque

		DN	80	100	125	150	200	250	300	350	400	450	500	600	700	800
Torque*,	CS		90	130	180	240	400	700	1'100	1'600	2'200	3'000	4'200	6'800	10'000	13'000
	Nm	TS	70	100	140	190	320	550	850	1'300	1'800	2'400	3'400	5'500	–	–

*) for steam duty use the next size up.

Handlever

The smaller sizes, DN 80 -150 can be operated with handlever.

The opening and closing of valves is stepless.

The valve is open when the handlever is in line with pipe.

DN	h	H	A
80	114	223	300
100	131	246	300
125	143	260	300
150	160	289	420

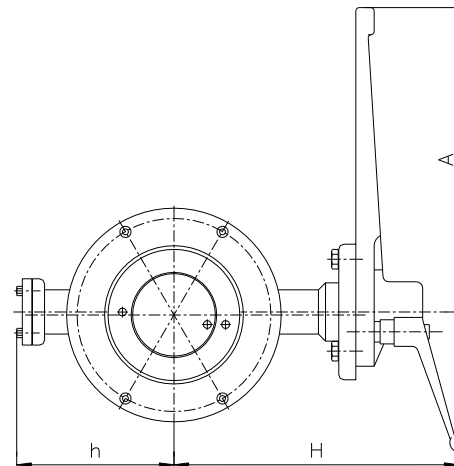

Manual gear

Opening and closing of the valves from the hand wheel.

The position of disc can be seen on a position indicator on top of the gear

DN	Rotork gear	D	h	H	a	b	c	d
80	AB210-10N	138	114	207	217	200	173	200
100	AB210-10N	158	131	231	217	200	197	200
125	AB210-10N	188	143	242	217	200	208	200
150	AB550N	212	160	287	247	200	240	200
200	AB550N	268	200	312	247	200	265	200
250	AB550N	320	232	357	282	300	310	300
300	AB880N	370	275	401	285	400	350	400
350	AB880N	430	303	428	285	400	377	400
400	AB1950N	482	333	506	387	500	435	500
450	AB1950N	530	358	534	387	500	463	500
500	AB2000N	585	388	578	382	53	522	500
600	AB6800SP4	685	448	689	500	500	589	500
700	AB6800SP4	785	498	761	500	500	661	500
800	AB6800SP6	885	565	809	545	500	709	500

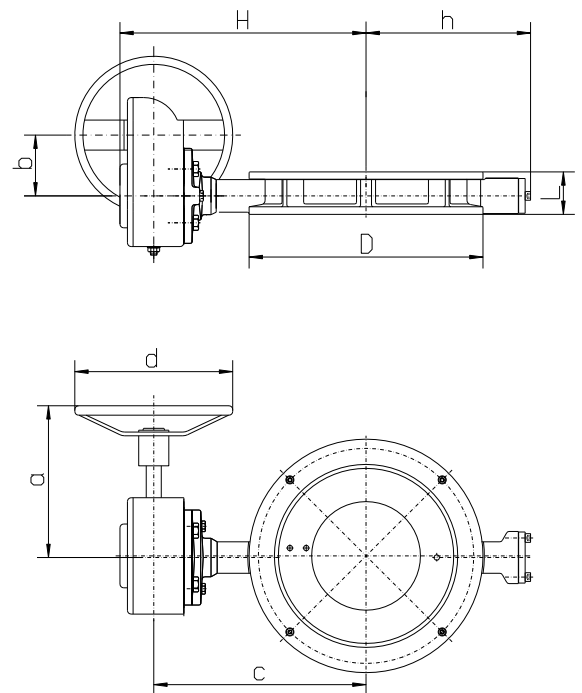

BUTTERFLY VALVE

wafer type

Pneumatic actuator

The typical combination of valve with Remote Control spring return actuator.

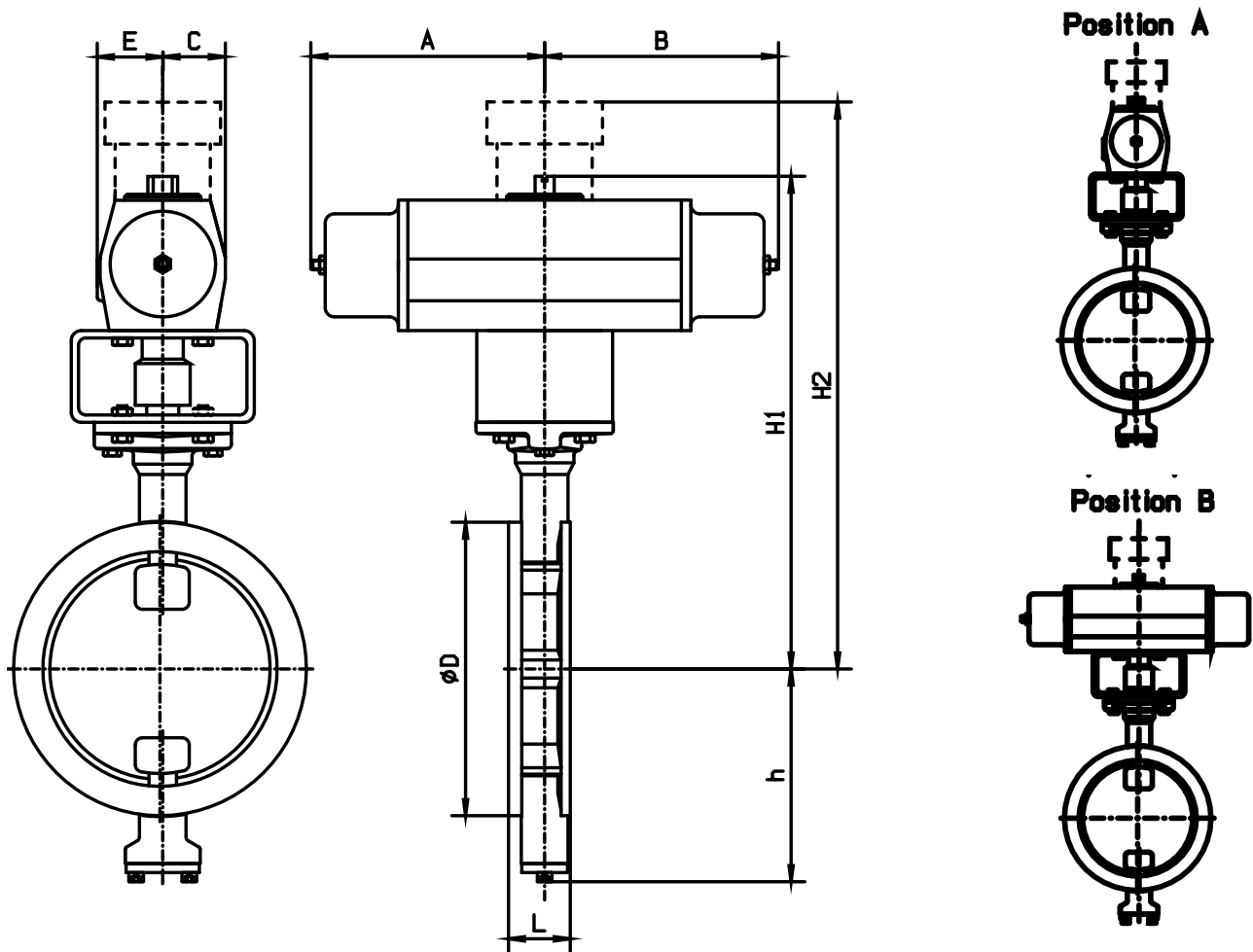

DN	RC model*	ØD	L			E	C	h	H1	A	B
			310	311	312						
80	RC250-SR	138	49	46	64	75	69	114	389	90	285
100	RC260-SR	158	56	52	64	75	69	131	413	285	285
125	RC260-SR	188	64	56	70	75	69	143	424	285	285
150	RC260-SR	212	70	56	76	75	69	160	474	285	285
200	RC270-SR	268	71	60	89	110	110	200	612	145	510
250	RC280-SR	320	76	68	114	110	110	232	647	510	510
300	RC88-SR	370	83	78	114	110	110	276	901	510	510
350	RC88-SR	430	92	78	127	110	110	303	975	510	510
400**	RC88-SR	482	-	102	140	110	110	333	1045	510	510
450**	RCG100	530	-	114	152	190	190	358	1038	850	850
500**	RCG100	585	-	127	152	190	190	388	1088	850	850

* at air pressure 6 bar

** ΔP max = 16 bar

BUTTERFLY VALVE

wafer type

Electric actuator

The one of the typical solutions is 311 series valve with AUMA Norm actuator.

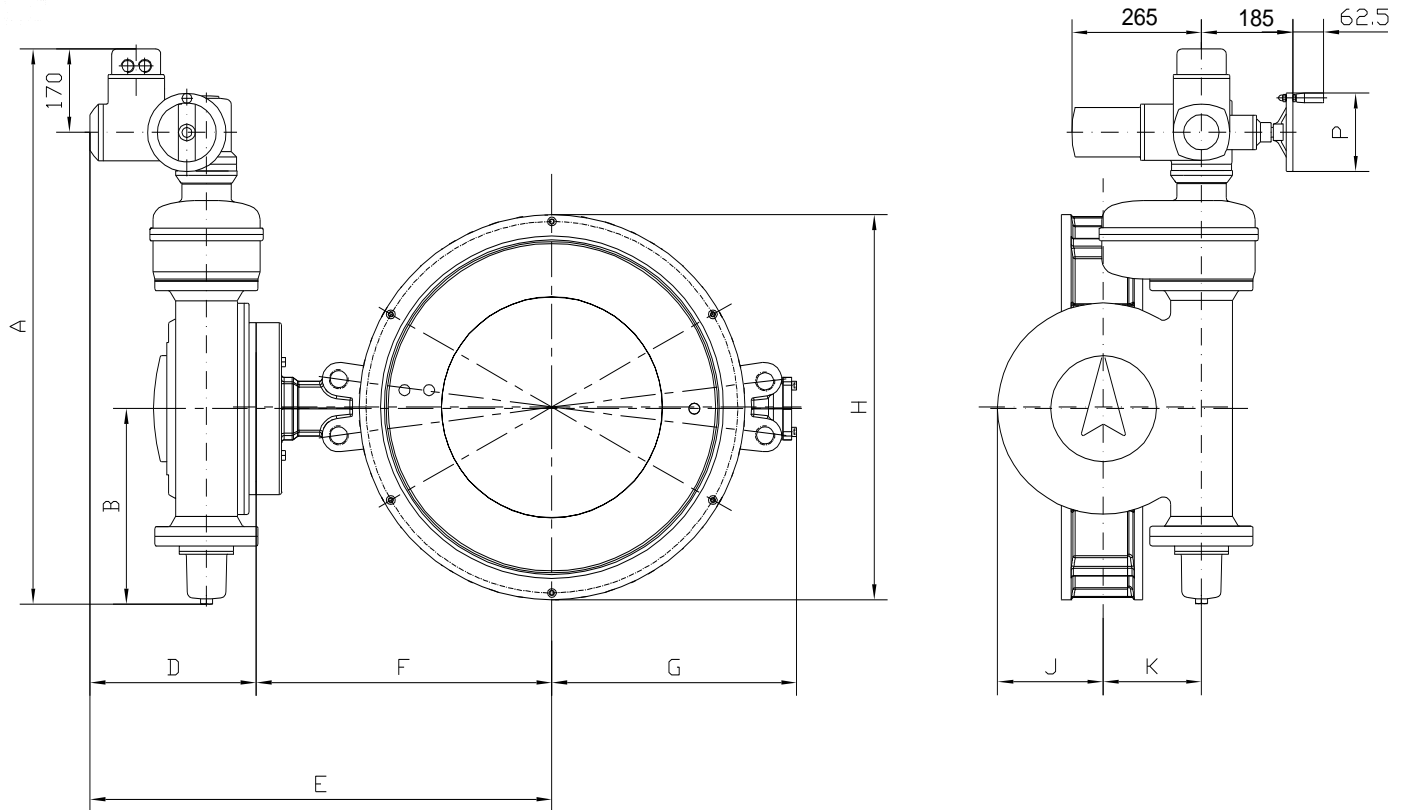

DN	AUMA type	A	B	D	E	F	G	H	J	K	P	Weight, kg
80	SA07.2-GS50.3 – F07	444	96	269	413	144	114	138	52	40	140	34
100	SA07.2-GS50.3 – F07	444	96	269	437	168	131	158	52	40	140	35
125	SA07.2-GS50.3 – F07	444	96	269	448	179	143	188	52	40	140	37
150	SA07.2-GS50.3 – F10	444	96	277	476	199	160	212	63	50	140	42
200	SA07.6-GS63.3 – F12	500	127	282	506	224	200	268	75	63	160	58
250	SA07.6-GS80.3 – F12	510	132	284	553	269	232	320	88	80	160	66
300	SA07.6-GS100.3/VZ4.3 – F14	689	182	312	620	308	275	370	105	100	160	97
350	SA07.6-GS100.3/VZ4.3 – F14	689	182	312	647	335	303	430	105	100	160	109
400	SA07.6-GS100.3/VZ4.3 – F16	689	182	312	692	380	333	482	105	100	160	143
450	SA10.2-GS125.3/VZ4.3 – F16	700	187	322	730	408	358	530	125	125	200	188
500	SA10.2-GS125.3/VZ4.3 – F16	700	187	322	780	458	388	585	125	125	200	231
600	SA07.6-GS160.3/GZ160.3 – F25	990	337	313	843	530	448	685	173	160	160	413
700	SA07.6-GS200.3/GZ200.3 – F30	1131	398	338	940	602	498	785	215	200	160	529
800	SA07.6-GS200.3/GZ200.3 – F30	1131	398	338	988	650	566	885	215	200	160	665

BUTTERFLY VALVE

wafer type

Mounting gasket

Mounting gasket must cover whole valve's contact surfaces.

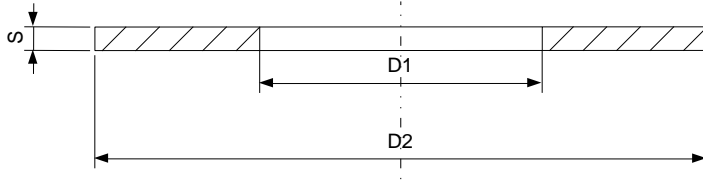

Gasket thickness "S" can be 0.5 – 3.0mm, 2.0mm is recommended.

DN	80	100	125	150	200	250	300	350	400	450	500	600	700	800	
D1*(mm)	90	115	141	169	220	274	325	368	420	470	520	620	720	820	
D2(mm)	PN10	142	162	192	218	273	328	378	438	490	540	595	695	810	915
	PN16	142	168	195	225	273	330	385	445	497	557	618	735	805	910
	PN25	142	168	195	225	285	342	402	458	515	565	625	730	830	940

D1* - maximum permissible size.

Pressure / Temperature Rating

The maximum working pressure ratings of the valve body

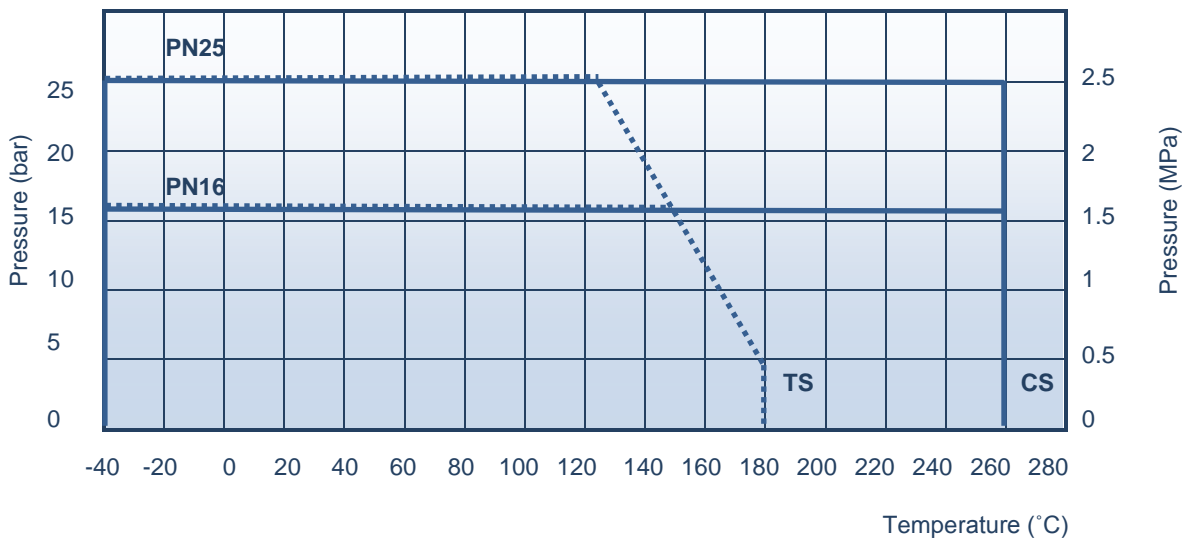

BUTTERFLY VALVE

wafer type

Flow curves

Indicating typical Kv values.

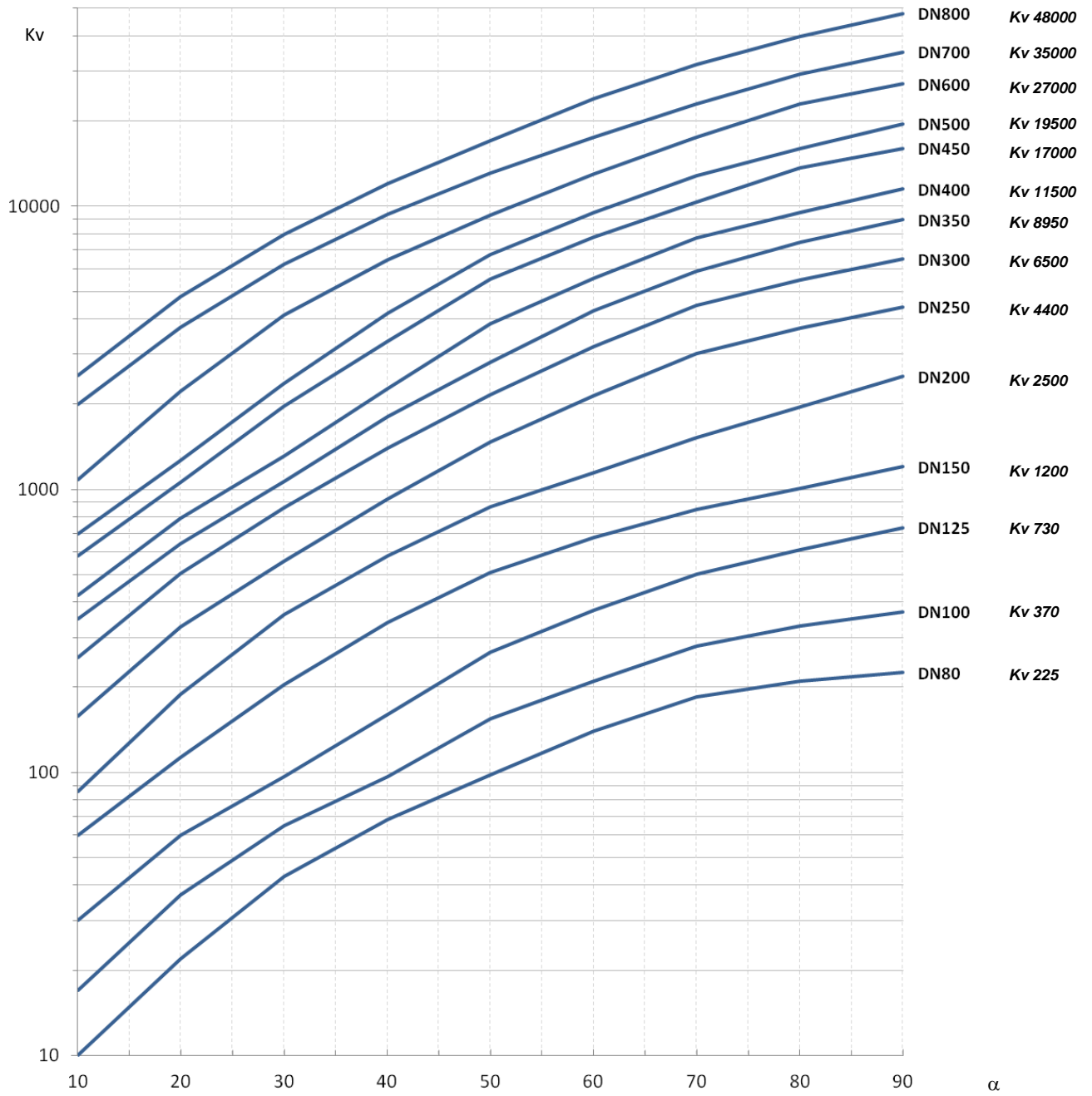

WATER:

Volume flow:

$$Q = K_v \sqrt{\frac{\Delta p}{\rho}}$$

Flow velocity:

$$V = 354 \frac{Q}{DN^2}$$

BUTTERFLY VALVE

wafer type

How to order

		3	1	1	00	CS	800	M	G
Body material:	3 – Carbon steel, 4 – Stainless steel								
Valve type:	1 - butterfly valve,								
Connection:	0, 1, 2 - wafer type, 3 - welded end, 5 – flanged,								
Special options:	00 – standard, 01 - For steam, 02 - PTFE+C seat								
Main seal	(CS) - Stainless steel, (TS) - PTFE+C								
Size DN									
Operation:	(_) - handlever, (Z) - bare shaft, (M) - manual gear (MF) – universal actuator								
	(G) – compatibility with GOST flanges								

BUTTERFLY VALVE WAFER TYPE stainless steel



Description

Edition 05-07-2017

Wafer type butterfly valve 411 (410) series are used in industrial pipe lines for demanding on-off and regulating tasks. The direction of the flow pressure is shown by the arrow. The body of this wafer type butterfly valve is full bore and made of stainless steel. The eccentric disc and stem are of stainless steel as well. Stem seals are tightable graphite seals and O-rings.

Nominal dimensions:	DN 80 - 200
Nominal pressure	PN40
Disk seal alternatives	Stainless steel (CS)
Closing pressure (ΔP)	40 bar
Tightness class ISO 5208, EN 12266-1	RATE B - standard, RATE A - option
* Working temperature of liquid media (version for steam also available)	+260°C -40°C
Face-to-face length according to ISO 5752	EN 558-1 Series 20 DIN3202 K1 or EN 558-1 Series 25 DIN3202 K2
Connection	Between neck-type flanges: EN1092-1 Type 11, Type B, PN40, PN25, PN16, PN10, ANSI CLASS 150. Size of assembly gasket in accordance to SFS 4378, DIN 2690. See page 6/9
Safety	Conform to the requirements of the Council Directive 2014/68/EU on Pressure Equipment, marking: Class: gas, group 1.  Explosion-proof design (EX) is available as per special order. Marking in accordance to ATEX Directive 94/9/EC: group II 2 GD, protection concept of non-electrical components: c T6. FIRE SAFE design as per special order.

*) Wider temperature range is available.

BUTTERFLY VALVE

wafer type

Exploded view

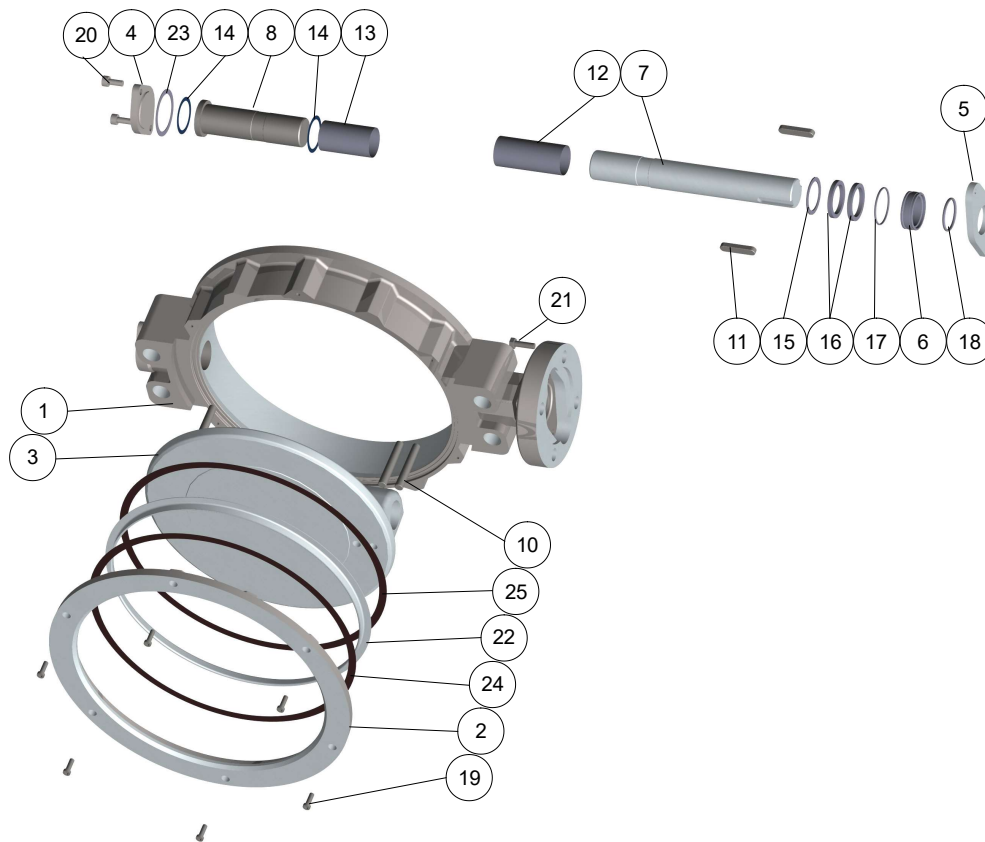

Parts list and standard materials

	Part	Material	
1	Body	Stainless steel ASTM A351 CF8M, EN10213 1.4408	
2	Counter flange	Stainless steel ASTM A351 CF8M, EN10213 1.4404	
3	Disk	Stainless steel ASTM A351 CF8M, EN10213 1.4408, SS2324	
4	Subshaft cover	Stainless steel EN10216-5 1.4436 / 1.4404	
5	Gland	Stainless steel EN10216-5 1.4436 / 1.4404	
6	Shaft seal bushing	Stainless steel EN10216-5 1.4404	
7	Main shaft	Stainless steel EN10088-3 1.4460 / 1.4418+QT900	
8	Subshaft	Stainless steel EN10088-3 1.4460 / 1.4418+QT900	
10	Pins	Stainless steel EN10088-3 1.4462 / 1.4418+QT900	
11	Key	Carbon steel 1.0503 DIN 6885A	
12	Stem bearing	PTFE on stainless steel net	
13	Subshaft bearing	PTFE on stainless steel net	
14	Bearing plate	PTFE on stainless steel net	
15	Back-up-ring	Stainless steel EN10216-5 1.4404	
16	Box packing	Graphite	
17,18	O-ring	FPM / EPDM	Not fitted in the steam version
19	Socket screw	Stainless steel ISO 3506 A4-80	
20	Socket screw	Stainless steel ISO 3506 A4-80	
21	Hexagonal screw	Stainless steel ISO 3506 A4-80	
22	Seat ring	Hard chrome plated stainless steel AISI316L	Special material by request
23	Bottom cover gasket	Carbon Fibre	Graphite for steam version
24, 25	Shim	Carbon Fibre	Graphite for steam version

BUTTERFLY VALVE

wafer type

Dimensions

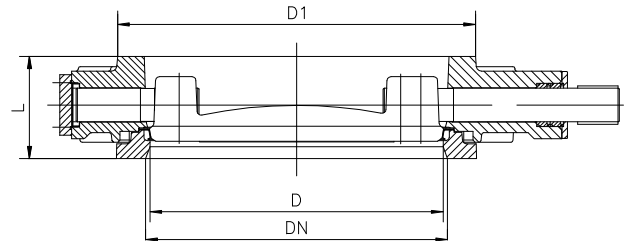
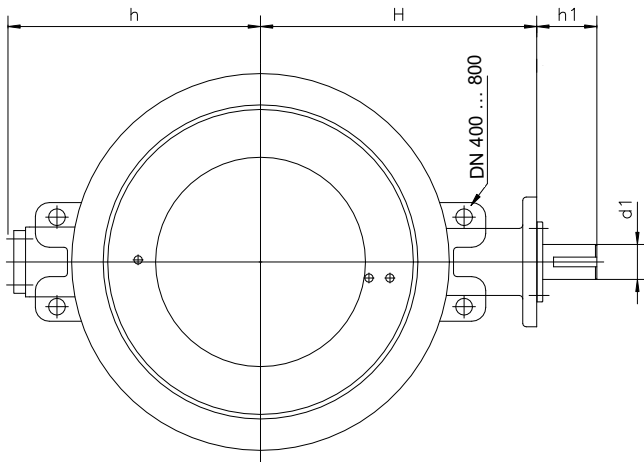

DN	L		D1	D	h	H	h1	d1	Flange ISO5211	Weight, kg		
	410	411								411 Bare shaft	With manual gear	
											410	411
80	49	46	138	72	114	144	45	15	F07	5,2	9,8	9,5
100	56	52	158	89	131	168	52	20	F07	6,8	11,5	11,1
125	64	56	188	113	143	179	52	20	F07	8,8	13,6	13,1
150	70	56	212	137	160	199	58	25	F10	12,5	24,6	22,5
200	71	60	268	187	200	224	58	25	F12	18,5	31	28,5

Operation

Valves can be equipped with an actuator to your specification.

- manual gear,
- electric actuator,
- pneumatic or hydraulic actuator.

Operation torque

DN	80	100	125	150	200
Torque* ,	135	180	250	285	505

*) for steam duty use the next size up.

BUTTERFLY VALVE

wafer type

Manual gear

Opening and closing of the valves from the handwheel.

The position of disc can be seen on a position indicator on top of the gear.

DN	D	h	H	a	b	c	d
80	138	114	204	218	45	171	200
100	158	131	228	218	45	195	200
125	188	143	239	218	45	206	200
150	212	160	286	220	71	240	200
200	268	200	311	220	71	265	200

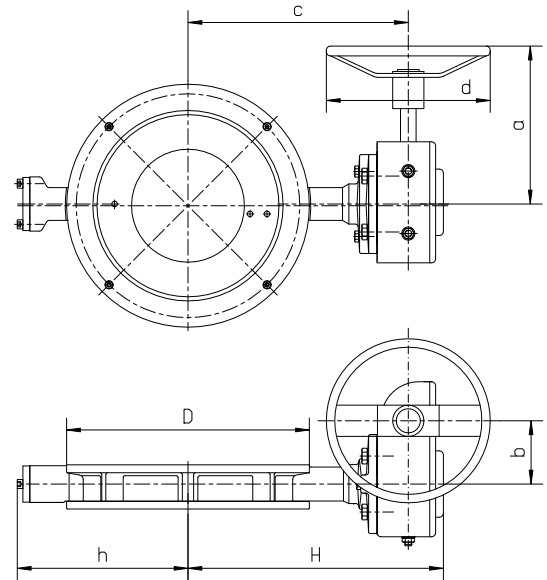

Electric actuator

The typical solution is 411 series valve with AUMA Norm actuator.

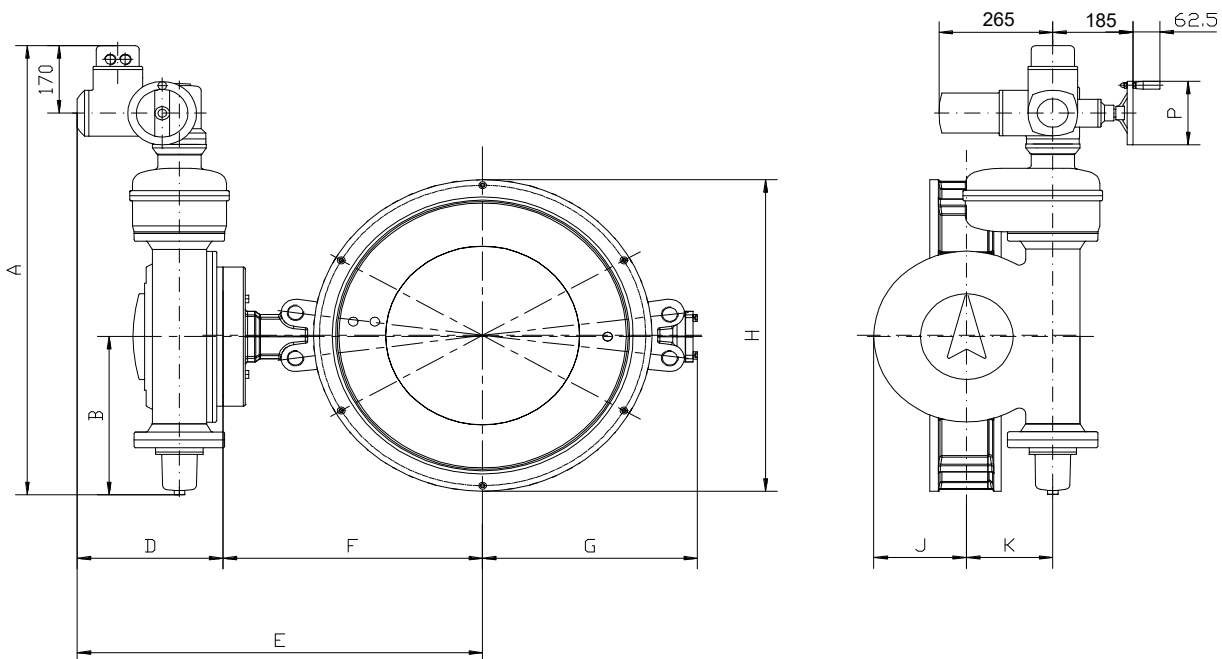

DN	AUMA type	A	B	D	E	F	G	H	J	K	P
80	SA07.1-GS50.3 – F07	444	96	269	413	144	114	138	52	40	140
100	SA07.1-GS50.3 – F07	444	96	269	437	168	131	158	52	40	140
125	SA07.1-GS50.3 – F07	444	96	269	448	179	143	188	52	40	140
150	SA07.1-GS50.3 – F10	444	96	277	476	199	160	212	63	50	140
200	SA07.5-GS63.3 – F12	500	127	282	506	224	200	268	75	63	160

BUTTERFLY VALVE

wafer type

Pneumatic actuator

The typical combination of valve with Remote Control spring return actuator.

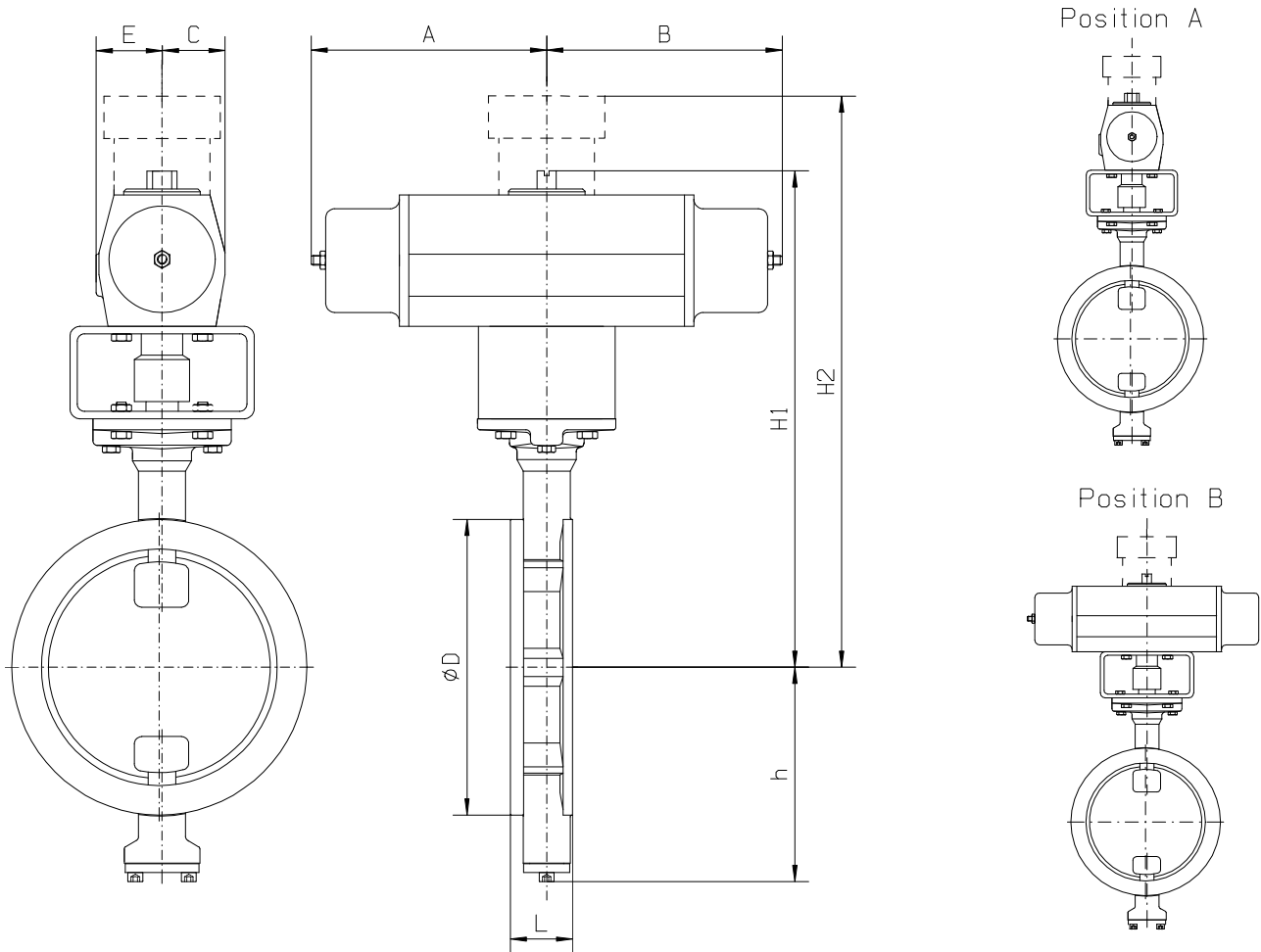

DN	RC model	ØD	L		E	C	h	H1	A	B
			410	411						
80	RC260-SR	138	49	46	75	69	114	389	285	285
100	RC260-SR	158	56	52	75	69	131	413	285	285
125	RC260-SR	188	64	56	75	69	143	424	285	285
150	RC260-SR	212	70	56	75	69	160	474	285	285
200	RC270-SR	268	71	60	110	110	200	612	145	510

BUTTERFLY VALVE

wafer type

Mounting gasket

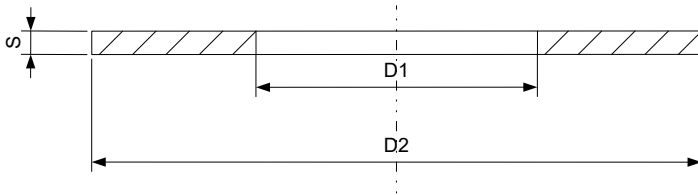

Gasket thickness "S" can be 0.5 – 3.0mm, 2.0mm is recommended.

PN40 DN	80	100	125	150	200
D1*(mm)	90	115	141	169	220
D2*(mm)	142	168	195	225	292

D1* - maximum permissible size.

Pressure / Temperature Rating

The maximum working pressure ratings of the valve body

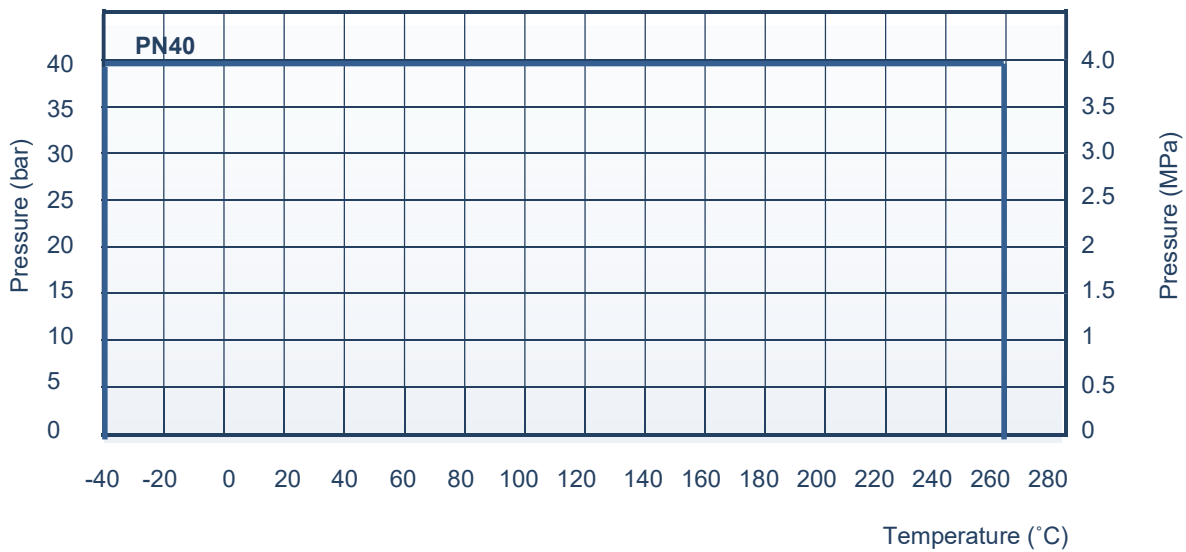

BUTTERFLY VALVE

wafer type

Flow curves

Indicating typical Kv values.

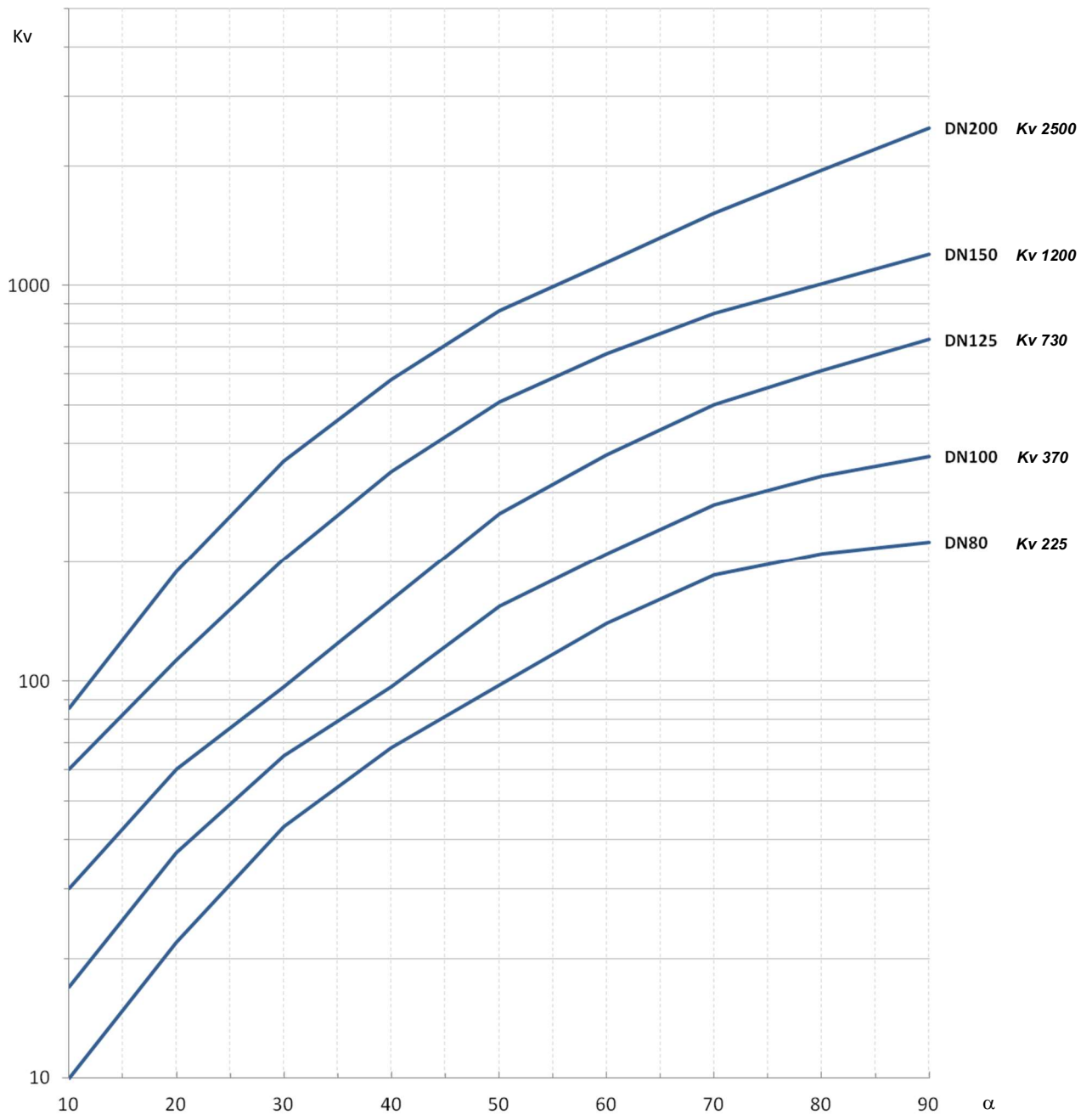

WATER:

Volume flow:

$$Q = K_v \sqrt{\frac{\Delta p}{\rho}}$$

Flow velocity:

$$V = 354 \frac{Q}{DN^2}$$

K_v = KV value – Capacity factor

DN = nominal valve size, mm

α = disc opening angle

Δp = pressure difference, bar

ρ = density of liquid, kg/dm³

V = flow velocity, m/s

Q = volume flow, m³/h

BUTTERFLY VALVE

wafer type

How to order

		4	1	1	00	CS	800	M
Body material:	3 – Carbon steel, 4 – Stainless steel							
Valve type:	1 - butterfly valve							
Connection:	0, 1, 2 - wafer type 3 - welded end 5 – flanged							
Special options:	00 – standard 01 - For steam 02 - PTFE+C seat							
Main seal	(CS) - Stainless steel (TS) - PTFE+C							
Size DN								
Operation:	(_) - handlever (Z) - bare shaft (M) - manual gear							



Klinger Portugal, Lda.
Via José Régio, 36
Centro Empresarial Vilar do Pinheiro
4485-860 Vila do Conde
T: +351 22 947 0910
E-mail: geral@klinger.pt

Delegação Lisboa
Rua de Cabo Verde, 8
Prior Velho 2685-316
T: +351 21 940 6620
E-mail: lisboa@klinger.pt