

Control Valves

Series 2003

Valve 3-way diverting/mixing

BUROCCO

INDUSTRIAL VALVES srl

Technical data

Size (DN)	DN 15 — 150
Pressure rating	PN16, PN40 ANSI 300
Connections	Flanges UNI/DIN PN16, PN40 Flanges ANSI 300
Type sealing	Metallic (Class IV - V), soft (Class VI)
Characteristic	Linear
Action	Pneumatic with diaphragm (supply max 3,5 bar)
Temperature	-196 to +350 °C

Description

Serie 2003 "Heavy Duty" control valves are linear, 3-way valves for industrial use. The Series 2003 valve offers superior performance in nearly all types in liquid and gaseous services within a wide temperature range. Due to the modular body construction the valves can easily be upgraded to special applications. The Series 2003 is the industry choice for a reliable and tough control valve. All Burocco valves are delivered as tested units and ready for a long lasting, maintenance free operation.

Options

- ⇒ Soft seal
- ⇒ Special 3 way DIVERTING CORRECT (size DN40-150)
- ⇒ High temperature extension (finned bonnet)
- ⇒ Extension (- 60 / - 100 °C)
- ⇒ Cryogenic extension (- 196 °C)
- ⇒ Bellows seal (double wall PN16, triple wall PN40)
- ⇒ Flanges drilling ANSI 150, (face to face) and rating UNI/DIN
- ⇒ Full stainless steel actuator for corrosive environment
- ⇒ Handwheel for emergency operation
- ⇒ Valve positioners
- ⇒ Limit switches
- ⇒ Position feedback
- ⇒ Airset
- ⇒ Electric linear actuators (230 V AC, 24 V AC/DC)



Flow rate coefficient (CV)

DN	CV			
	4	2,5	-	-
15	4	2,5	-	-
20	7	4	2,5	-
25	12	7	4	-
32	18	12	7	4
40	28	18	12	7
50	48	28	18	12
65	72	48	28	18
80	105	72	48	28
100	160	105	72	48
150	300	210	160	105

Control Valves
 Series 2003
 Valve 3-way diverting/mixing

BUROCCO
INDUSTRIAL VALVES srl

Materials	
Valve body *	Nodular cast iron GGG 40 (PN16)
	Carbon steel ASTM A216WCB
	Stainless steel ASTM CF8M
Trim (plug - seat)	316L / 17-4PH / 316L+Stellite / Hastelloy / Monel
Stem	316L / Hastelloy / Monel
Packing	PTFE, PTFE/CG, graphite, special
Body gasket	SIL C4500, NOVAPHIT, PTFE, special
Acuator	FE (epoxy varnish), stainless steel
Yoke	GGG 40 (epoxy varnish), stainless steel

* Special body materials on request

Function overview

Diverting serie 2003D

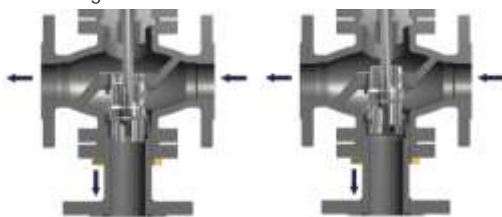

Normally open straight way Normally open square way

Mixing serie 2003M

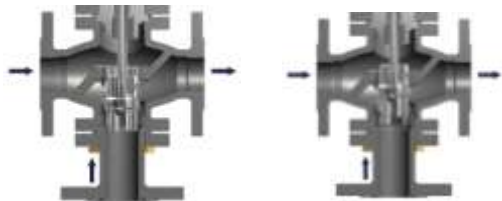

Normally open straight way Normally open square way

Bonnet specifications (temperatures limit employment)



Standar (-30°C / +250 °C)

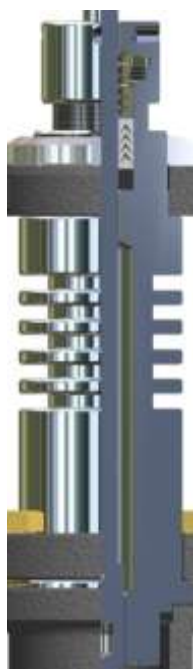

Finned (-30°C / +350 °C)



Bellows (-100°C / +350 °C)

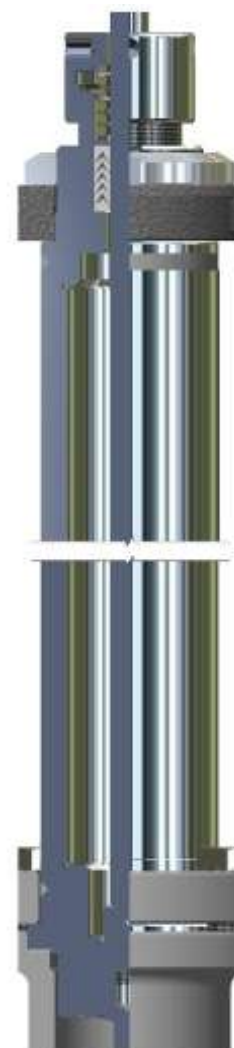

Criogenic (-196°C / +180 °C)

Control Valves
Series 2003
Valve 3-way diverting/mixing

Dimensions (mm) and weight (kg) serie 2003 - UNI/DIN PN16/40

Special actuator double for DN100/150

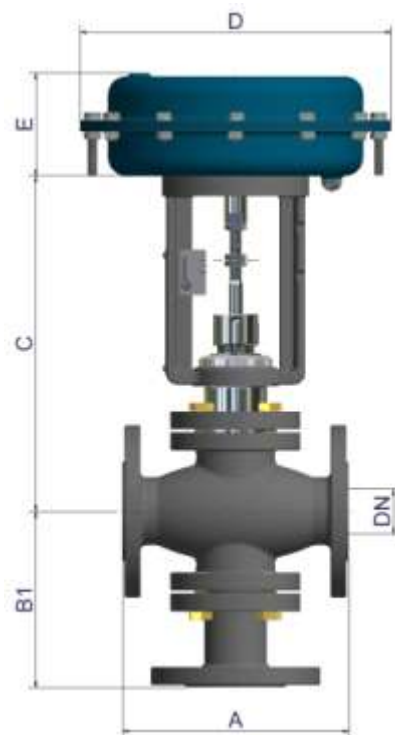

Actuator S430 DOUBLE	DN100	DN150	
	S430	S430	S430 HP
E (mm)	270	310	390
Indicative weight (kg)*	108	214	230

Dimensions (mm)

DN	A	B1	C						D	E
			Standard	-60 °C (extension)	-100 °C (extension)	-200 °C (criogenic)	High.Temp. (finned)	Bellows		
15	130	156	297	359	434	729	382	403	205 / 275	88 / 100
20	150	156	297	359	434	729	382	403	205 / 275	88 / 100
25	160	156	297	359	434	729	382	403	205 / 275	88 / 100
32	180	156	297	359	434	729	382	403	275 / 340	100 / 135
40	200	156	297	359	434	729	382	403	275 / 340	100 / 135
50	230	166	297	359	434	729	382	403	275 / 340	100 / 135
65	290	220	333	395	470	765	418	439	340 / 430	135
80	310	220	333	395	470	765	418	439	340 / 430	135
100	350	240	350	412	487	782	435	456	430	135
150	480	350	495	-	642	990	642	On request	430 / 430HP	160 / 200

Indicative weight*

DN	15	20	25	32	40	50	65	80	100	150
kg	18 / 21	20 / 23	21 / 24	28 / 34	29 / 35	36 / 42	61 / 67	65 / 71	90	192 / 200

* without positioner, airset or other accessories

Extra weight with bonnet extension

DN	-60 / -100 °C	-200 °C	High Temp.	Bellows
15-50	+ 2	+ 3,5	+ 1	+ 1,5
65-100	+ 2	+ 4	+ 3	+ 2
150	+ 5	+ 15	+ 10	On request

Control Valves
Series 2003
Valve 3-way diverting/mixing

BUROCCO
INDUSTRIAL VALVES srl

Dimensions (mm) and weight (kg) serie 2003 - ANSI 300

Special actuator double for DN100/150



Actuator S430 DOUBLE	DN100	DN150	
	S430	S430	S430 HP
E (mm)	270	310	390
Indicative weight (kg)*	112	224	240

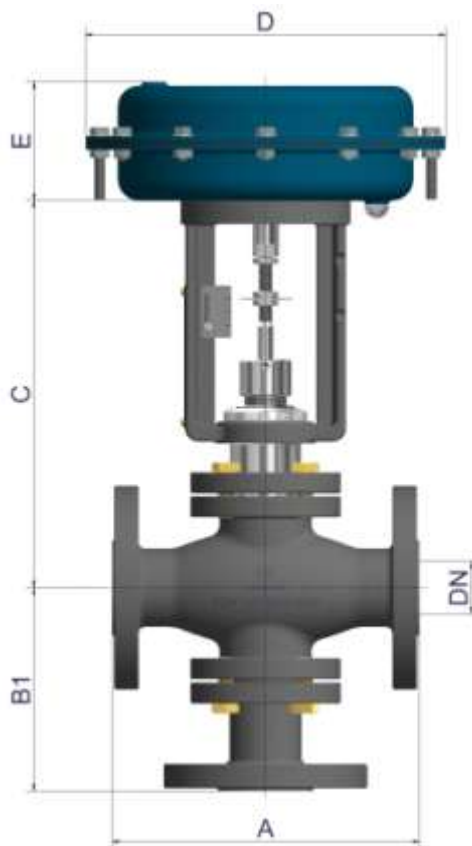

Dimensions (mm)

DN	A	B1	C						D	E
			Standard	-60 °C (extension)	-100 °C (extension)	-200 °C (criogenic)	High.Temp. (finned)	Bellows		
25	197	156	297	359	434	729	382	403	205 / 275	88 / 100
40	235	156	297	359	434	729	382	403	275 / 340	100 / 135
50	267	166	297	359	434	729	382	403	275 / 340	100 / 135
80	318	220	333	395	470	765	418	439	340 / 430	135
100	368	240	350	412	487	782	435	456	430	135
150	473	350	495	-	642	990	642	On request	430 / 430HP	160 / 200

Indicative weight*

DN	25	40	50	80	100	150
kg	21 / 24	30 / 36	38 / 44	67 / 73	94	202 / 210

* without positioner, airset or other accessories

Extra weight with bonnet extension

DN	-60 / -100 °C	-200 °C	High Temp.	Bellows
25-50	+ 2	+ 3,5	+ 1	+ 1,5
80-100	+ 2	+ 4	+ 3	+ 2
150	+ 5	+ 15	+ 10	On request



Klinger Portugal, Lda.
Via José Régio, 36
Centro Empresarial Vilar do Pinheiro
4485-860 Vila do Conde
T: +351 22 947 0910
E-mail: geral@klinger.pt

Delegação Lisboa
Rua de Cabo Verde, 8
Prior Velho 2685-316
T: +351 21 940 6620
E-mail: lisboa@klinger.pt