

# Control Valves

## Series EURO

Valve 2 way

# BUROCCO

## INDUSTRIAL VALVES srl

### Technical data

Size (DN)	DN 15 — 150
Pressure rating	PN16, PN40
Connections	Flanges UNI/DIN PN16, PN40
Type sealing	Soft (Class VI) Metallic (Class IV - V)
Characteristic	Equalpercentage (eqp%)
Action	Pneumatic with diaphragm (supply max 3 bar)
Temperature	from -20 to +205 °C

### Description

The Series EURO control valve is a general service valve. The precise machined plug and seat give an excellent control performance. The plug is guided in its upper part. They are particularly indicated for regulation in medium/light plants. The Series EURO control valve is the best choice for a simple and reliable globe valve. All Burocco valves are delivered after testing and calibration and ready for a long utilize, without maintenance.



### Options

- ⇒ Characteristic linear
- ⇒ Metallic seal
- ⇒ Full stainless steel actuator for corrosive environment
- ⇒ Low Noise
- ⇒ Stroke limiter
- ⇒ Handwheel for emergency operation
- ⇒ Valve positioners
- ⇒ Limit switches
- ⇒ Position feedback
- ⇒ Airset
- ⇒ Electric linear actuators  
(230 V AC, 110/115 V AC, 24 V AC/DC)

### Flow rate coefficient (CV)

DN	CV					
	4	2,5 - 1,5	1 - 0,5	0,3 - 0,1	-	-
15	4	2,5 - 1,5	1 - 0,5	0,3 - 0,1	-	-
20	7	4	2,5 - 1,5	1 - 0,5	0,3 - 0,1	-
25	12	7	4	2,5 - 1,5	1 - 0,5	0,3 - 0,1
32	18	12	7	4	2,5 - 1,5	1 - 0,5
40	28	18	12	7	4	2,5 - 1,5
50	48	28	18	12	7	4
65	72	48	28	18	-	-
80	105	72	48	28	-	-
100	160	105	72	48	28	-
125	210	160	105	72	-	-
150	300	210	160	105	72	-

CV Available only for Nodular cast iron GGG 40 (PN16)

CV Available only for 1.0619 and S.S. CF8M (PN16 - PN40)

CV Available with all materials

# Control Valves

## Series EURO

Valve 2 way

# BUROCCO

## INDUSTRIAL VALVES srl

Materials	
Valve body	Nodular cast iron GGG 40 (PN16) Carbon steel 1.0619 Stainless steel ASTM CF8M
Trim (plug - seat)	316L / 17-4PH / 316L+Stellite
Stem	316L
Packing	PTFE, PTFE+'OR' FPM, special
Body gasket	FASIT 400, SIL C4500, PTFE, special
Acuator	FE (epoxy varnish) Stainless steel
Yoke	GGG 40 (epoxy varnish) Stainless steel

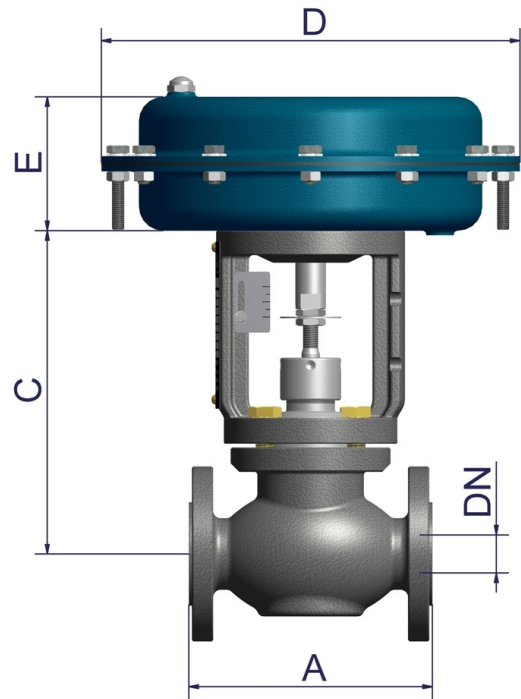

### Control characteristic

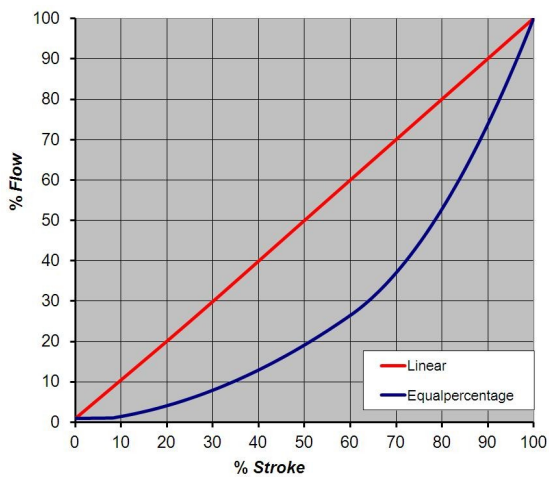

### Standard dimensions (mm)

DN	A	C	D	E
15	130	212	205 / 275	88 / 100
20	150	212	205 / 275	88 / 100
25	160	212	205 / 275	88 / 100
32	180	212	275 / 340	100 / 135
40	200	212	275 / 340	100 / 135
50	230	212	275 / 340 / 430	100 / 135 / 135
65	290	298	340 / 430	135
80	310	298	340 / 430	135
100	350	318	430	135
125	400	430	430	185
150	480	430	430	185

### Indicative weight\*

DN	15	20	25	32	40	50	65	80	100	125	150
kg	12 / 15	13 / 16	15 / 18	20 / 26	22 / 28	28 / 34 / 39	50 / 56	55 / 60	71	110	135

\* without positioner, airset or other accessories



Klinger Portugal, Lda.  
Via José Régio, 36  
Centro Empresarial Vilar do Pinheiro  
4485-860 Vila do Conde  
T: +351 22 947 0910  
E-mail: geral@klinger.pt

Delegação Lisboa  
Rua de Cabo Verde, 8  
Prior Velho 2685-316  
T: +351 21 940 6620  
E-mail: lisboa@klinger.pt